



AFRL-RX-TY-TR-2011-0021

PRECAST/PRESTRESSED CONCRETE EXPERIMENTS PERFORMANCE ON NON-LOAD BEARING SANDWICH WALL PANELS

Clay J. Naito
Department of Civil and Environmental Engineering
Lehigh University
117 ATLSS Drive
Bethlehem, PA 18015

John M. Hoemann
U.S. Army Engineer Research & Development Center
3909 Halls Ferry Road
CEERD-GS-M
Vicksburg, MS 39180-6199

Jonathon S. Shull
Black & Veatch, Federal Services Division
1805 Meadow Moor Drive
Webb City, MO 64870

Aaron Saucier and Hani A. Salim
Department of Civil and Environmental Engineering
University of Missouri
E2509 Lafferre Hall
Columbia, MO 65211-2200

Bryan T. Bewick and Michael I. Hammons
Airbase Technologies Division
Air Force Research Laboratory
139 Barnes Drive, Suite 2
Tyndall Air Force Base, FL 32403-5323

Contract No. FA8903-08-D-8768-0002

January 2011

DISTRIBUTION STATEMENT A: Approved for public release; distribution is unlimited.

**AIR FORCE RESEARCH LABORATORY
MATERIALS AND MANUFACTURING DIRECTORATE**

■ Air Force Materiel Command ■ United States Air Force ■ Tyndall Air Force Base, FL 32403-5323

DISCLAIMER

Reference herein to any specific commercial product, process, or service by trade name, trademark, manufacturer, or otherwise does not constitute or imply its endorsement, recommendation, or approval by the United States Air Force. The views and opinions of authors expressed herein do not necessarily state or reflect those of the United States Air Force.

This report was prepared as an account of work sponsored by the United States Air Force. Neither the United States Air Force, nor any of its employees, makes any warranty, expressed or implied, or assumes any legal liability or responsibility for the accuracy, completeness, or usefulness of any information, apparatus, product, or process disclosed, or represents that its use would not infringe privately owned rights.

NOTICE AND SIGNATURE PAGE

Using Government drawings, specifications, or other data included in this document for any purpose other than Government procurement does not in any way obligate the U.S. Government. The fact that the Government formulated or supplied the drawings, specifications, or other data does not license the holder or any other person or corporation; or convey any rights or permission to manufacture, use, or sell any patented invention that may relate to them.

This report was cleared for public release by the 88th Air Base Wing Public Affairs Office at Wright Patterson Air Force Base, Ohio and is available to the general public, including foreign nationals. Copies may be obtained from the Defense Technical Information Center (DTIC) (<http://www.dtic.mil>).

AFRL-RX-TY-TR-2011-0021 HAS BEEN REVIEWED AND IS APPROVED FOR PUBLICATION IN ACCORDANCE WITH ASSIGNED DISTRIBUTION STATEMENT.

**BEWICK.BRYAN
.T.1290370414**

Digitally signed by
BEWICK.BRYAN.T.1290370414
DN: c=US, o=U.S. Government, ou=DoD,
ou=PKI, ou=USAF,
cn=BEWICK.BRYAN.T.1290370414
Date: 2011.04.01 10:59:23 -05'00'

BRYAN T. BEWICK
Work Unit Manager

**RHODES.ALBERT.
N.III.1175488622**

Digitally signed by
RHODES.ALBERT.N.III.1175488622
DN: c=US, o=U.S. Government, ou=DoD,
ou=PKI, ou=USAF,
cn=RHODES.ALBERT.N.III.1175488622
Date: 2011.06.02 07:01:44 -05'00'

ALBERT N. RHODES, PhD
Chief, Airbase Technologies Division

**RICHLIN.DEBRA
.L.1034494149**

Digitally signed by
RICHLIN.DEBRA.L.1034494149
DN: c=US, o=U.S. Government,
ou=DoD, ou=PKI, ou=USAF,
cn=RICHLIN.DEBRA.L.1034494149
Date: 2011.04.05 15:38:39 -05'00'

DEBRA L. RICHLIN
Chief, Airbase Engineering Development Section

This report is published in the interest of scientific and technical information exchange, and its publication does not constitute the Government's approval or disapproval of its ideas or findings.

REPORT DOCUMENTATION PAGE

*Form Approved
OMB No. 0704-0188*

The public reporting burden for this collection of information is estimated to average 1 hour per response, including the time for reviewing instructions, searching existing data sources, gathering and maintaining the data needed, and completing and reviewing the collection of information. Send comments regarding this burden estimate or any other aspect of this collection of information, including suggestions for reducing the burden, to Department of Defense, Washington Headquarters Services, Directorate for Information Operations and Reports (0704-0188), 1215 Jefferson Davis Highway, Suite 1204, Arlington, VA 22202-4302. Respondents should be aware that notwithstanding any other provision of law, no person shall be subject to any penalty for failing to comply with a collection of information if it does not display a currently valid OMB control number.

PLEASE DO NOT RETURN YOUR FORM TO THE ABOVE ADDRESS.

1. REPORT DATE (DD-MM-YYYY) 31-JAN-2011	2. REPORT TYPE Final Technical Report	3. DATES COVERED (From - To) 11-AUG-2008 -- 20-NOV-2010
---	---	---

4. TITLE AND SUBTITLE Precast/Prestressed Concrete Experiments Performance on Non-Loadbearing Sandwich Wall Panels	5a. CONTRACT NUMBER FA8903-08-D-8768-0002
	5b. GRANT NUMBER
	5c. PROGRAM ELEMENT NUMBER 99999F

6. AUTHOR(S) # Naito, Clay J.; ## Hoemann, John M.; ** Shull, Jonathon S.; ### Saucier, Aaron; ### Salim, Hani A.; * Bewick, Bryan T.; * Hammons, Michael I.	5d. PROJECT NUMBER GOVT
	5e. TASK NUMBER F0
	5f. WORK UNIT NUMBER QF101000

7. PERFORMING ORGANIZATION NAME(S) AND ADDRESS(ES) **Black & Veatch, 1805 Meadow Moor Drive, Webb City, MO 64870; #Lehigh University, 117 ATLSS Drive, Bethlehem, PA 18015; ##U.S. Army Engineer Research & Development Center, 3909 Halls Ferry Road, Vicksburg, MS 39180-6199; ###University of Missouri, E2509 Lafferre Hall, Columbia, MO 65211-2200	8. PERFORMING ORGANIZATION REPORT NUMBER
--	---

9. SPONSORING/MONITORING AGENCY NAME(S) AND ADDRESS(ES) *Air Force Research Laboratory Materials and Manufacturing Directorate Airbase Technologies Division 139 Barnes Drive, Suite 2 Tyndall Air Force Base, FL 32403-5323	10. SPONSOR/MONITOR'S ACRONYM(S) AFRL/RXQEM
	11. SPONSOR/MONITOR'S REPORT NUMBER(S) AFRL-RX-TY-TR-2011-0021

12. DISTRIBUTION/AVAILABILITY STATEMENT
Distribution Statement A: Approved for public release; distribution unlimited.

13. SUPPLEMENTARY NOTES
Ref Public Affairs Case # 88ABW-2011-3242, 7 June 2011. Document contains color images.

14. ABSTRACT
To comply with the energy efficiency and build green initiatives contained in the Energy Policy Act of 2005 and Energy Independence Security Act of 2007, the Anti-Terrorism and Force Protection (ATFP) requirements for building construction, and the “build-it faster and more economical” requirements of the Military Construction Transformation initiative, a research program has been conducted by AFRL and the Portland Cement Association (PCA) on the performance of insulated concrete wall panels. The purpose of the research is to determine if commercially available wall systems with excellent energy savings performance can provide ATFP for military and government facilities. This report presents the static performance of the wall systems subjected to pseudo-blast pressures. The results indicate that sandwich wall systems provide blast resistance over a large deformation range making these systems useful for ATFP applications. The responses of the panels were found to be sensitive to reinforcement type, shear ties used, and insulation.

15. SUBJECT TERMS
insulated concrete wall panels, sandwich wall systems, blast resistance

16. SECURITY CLASSIFICATION OF:			17. LIMITATION OF ABSTRACT UU	18. NUMBER OF PAGES 162	19a. NAME OF RESPONSIBLE PERSON Bryan T. Bewick
a. REPORT U	b. ABSTRACT U	c. THIS PAGE U			19b. TELEPHONE NUMBER (Include area code)

TABLE OF CONTENTS

LIST OF FIGURES	iii
LIST OF TABLES	viii
1. INTRODUCTION	1
2. OBJECTIVES	2
2.1. Wall Performance Criteria	2
3. INSULATED SANDWICH WALLS	5
3.1. Sandwich Wall Configurations	6
3.2. Insulation Foam Properties	7
3.2.1. Shear Tie Types	8
4. DETAILS OF STATIC SPECIMENS	9
4.1. Single-span Panels with Idealized Supports	9
4.2. Multi-span Panels with Intermediate Connections	17
4.2.1. Midspan Connection Details	18
4.3. Single-span Panels with End Connections	26
4.4. As-built Properties	30
5. EXPERIMENTAL SETUP	31
5.1. Instrumentation	33
5.2. Material Properties	34
5.3. Reinforcement Materials	34
5.4. Concrete Material Properties	35
6. EXPERIMENTAL RESULTS FOR SINGLE-SPAN PANELS	37
6.1. TS1 6-2-3 Specimen Performance	39
6.2. TS2 3-2-3 Specimen Performance	42
6.3. PCS1 3-2-3 Specimen Performance	46
6.4. PCS2 3-2-3 Specimen Performance	50
6.5. PCS3 3-2-3 Specimen Performance	54
6.6. PCS3 (Type 2) 3-2-3 Specimen Performance	59
6.7. PCS4 3-3-3 Specimen Performance	63
6.8. PCS5 3-3-3 Specimen Performance	69
6.9. PCS6 3-3-3 Specimen Performance	74
6.10. PCS7 3-3-3 Specimen Performance	80
6.11. PCS8 3-3-3 Specimen Performance	85
6.12. PCS9 3-3-3 Specimen Performance	90
6.13. Tyn1 3-4-3 Specimen Performance (Bonded Strand)	94
6.14. Tyn2 3-4-3 Specimen Performance (Unbonded)	98
7. SINGLE-SPAN PANELS WITH END CONNECTION RESULTS	102
7.1. PCS10 3-3-3 Specimen Performance	102
7.2. PCS11 3-3-3 Specimen Performance	106
8. MULTI SPAN PANEL RESULTS	111
8.1. PCD1 3-3-3 Specimen Performance	111
8.2. PCD2 3-3-3 Specimen Performance	116
8.3. TS3-A and B 6-2-3 Specimen Performance	122
8.4. TS3-C and D 6-2-3 Specimen Performance	125
8.5. TS3-E and F 6-2-3 Specimen Performance	129
9. DISCUSSION OF RESULTS	133

9.1.	Single-span Panels	133
9.1.1.	Backbone Estimation of Response.....	137
9.1.2.	Estimation of Yield in Sandwich Wall Panels.....	141
9.2.	Multi-span Panels.....	142
10.	CONCLUSIONS AND FUTURE WORK.....	145
10.1.	Further Research	146
11.	REFERENCES	147
	LIST OF SYMBOLS, ABBREVIATIONS, AND ACRONYMS	148

LIST OF FIGURES

Figure	Page
1. Sandwich Panel Cross-Section	5
2. Tilt-up Concrete Sandwich Wall Construction [TCA 2006]	5
3. Prestressed Concrete Sandwich Wall Construction [PCI 1997]	6
4. TCA and PCI Wall Sections (c and d [PCI 1997])	7
5. Shear Ties Samples	8
6. Prototype TCA 3-2-3 Wall.....	11
7. Prototype TCA 6-2-3 Wall.....	11
8. TCA Non-composite 6-2-3 Single-span Static Specimen TS1 Details	12
9. TCA Composite 3-2-3 Single-span Static Specimen TS2 Details.....	13
10. Metromont PCI Prototype Wall Panel Design.....	14
11. Coreslab PCI Prototype Wall Panel Design.....	14
12. PCI Panel Reinforcement.....	16
13. Control Panel Reinforcement.....	17
14. Tyndall Panel Reinforcement	17
15. TCA Two-span Details TS3-A and B.....	19
16. TCA Two-span Details TS3-C and D.....	20
17. TCA Two-span Details TS3-E and F.....	21
18. Coreslab Two-span Panel PCD1.....	22
19. Metromont Two-span Panel PCD2.....	23
20. MeadowBurke Halfen Insert Capacity [Meadow Burke 2011]	23
21. TS3-A and B Connection Details	24
22. JVI PSA Insert	24
23. Connection Details for PCI Panels PCD1 and PCD2	25
24. Connection Details.....	25
25. Specimen PCS10—Top Connection.....	26
26. Specimen PCS11—Base Connection	27
27. Connection Loading Plan.....	28
28. PCS10 Connection Details.....	28
29. PCS11 Connection Details.....	29
30. Embed to Support Connection Detail (PCS10 and 11).....	29
31. Single-span Loading Tree	31
32. Single-span Loading Tree Schematic	31
33. Two-span Loading Tree	32
34. Schematic of Single and Two-span Fixtures	32
35. Schematic of End Connection Setup.....	32
36. Displacement Instrumentation	33
37. End Shear Instrumentation.....	33
38. TS1 Reinforcement Details.....	39
39. TS1 6-2-3 Pressure—Midspan Displacement.....	40
40. TS1 6-2-3 Moment—Rotation.....	40
41. TS1-A Detail Results	41
42. TS1-B Detail Results	41
43. TS1-C Detail Results	41
44. TS1 Panel Response (A, B, C).....	42

45.	TS2 Reinforcement Details.....	42
46.	3-2-3 Pressure—Midspan Displacement	43
47.	TS2 3-2-3 Moment Rotation at Midspan.....	44
48.	TS2-A Detail Results	44
49.	TS2-B Detail Results	45
50.	TS2-C Detail Results	45
51.	TS2 Panel Response (A, B, C).....	45
52.	PCS1 Cross-Section Detail	46
53.	PCS1 Panel Detail.....	46
54.	PCS1 Pressure–Displacement Response.....	47
55.	PCS1 Moment–Rotation Response.....	48
56.	PCS1-A Response.....	48
57.	PCS1-B Response	49
58.	PCS1-C Response	49
59.	PCS1 Panel Response	50
60.	PCS2 Cross-Section Detail	50
61.	PCS2 Panel Detail.....	51
62.	PCS2 Pressure–Displacement Response.....	51
63.	PCS2 Moment–Rotation Response.....	52
64.	PCS2-A Response.....	52
65.	PCS2-B Pressure–Displacement Response.....	53
66.	PCS2-C Response	53
67.	PCS2 Panel Response (A, B, C)	54
68.	PCS3 Cross-Section Detail	54
69.	PCS3 Panel Detail.....	55
70.	PCS3 Pressure–Displacement Response.....	56
71.	PCS3 Moment–Rotation Response.....	56
72.	PCS3-A Response.....	57
73.	PCS3-B Response	57
74.	PCS3-C Response	58
75.	PCS3 Panel Response (A, B, C)	58
76.	PCS3 (Type 2) Cross-Section Detail	59
77.	PCS3 (Type 2) Panel Detail.....	59
78.	PCS3 (Type 2) Pressure–Displacement Response.....	60
79.	PCS3 (Type 2) Moment–Rotation Response.....	61
80.	PCS3-D Response.....	61
81.	PCS3-E Response	62
82.	PCS3-F Response.....	63
83.	PCS3 (Type 2) Panel Response (D, E, F)	63
84.	PCS4 Cross-Section Detail	64
85.	PCS4 Panel Detail.....	64
86.	PCS4 Panel Detail 2.....	65
87.	PCS4 Pressure–Displacement Response.....	66
88.	PCS4 Moment–Rotation Response.....	66
89.	PCS4-A Response.....	67
90.	PCS4-B Response	68

91.	PCS4-C Response	69
92.	PCS4 Panel Response (A, B, C)	69
93.	PCS5 Cross-Section Detail	70
94.	PCS5 Panel Detail.....	70
95.	PCS5 Pressure–Displacement Response.....	71
96.	PCS5 Moment–Rotation Response.....	72
97.	PCS5-A Response.....	72
98.	PCS5-B Response	73
99.	PCS5-C Response	74
100.	PCS5 Panel Response (A, B, C)	74
101.	PCS6 Cross-Section Detail	75
102.	PCS6 Panel Detail.....	75
103.	PCS6 Pressure–Displacement Response.....	76
104.	PCS6 Moment–Rotation Response.....	76
105.	PCS6-A Response.....	77
106.	PCS6-B Response	78
107.	PCS6-C Response	79
108.	PCS6 Panel Response (A, B).....	79
109.	PCS7 Cross-Section Detail	80
110.	PCS7 Panel Detail.....	80
111.	PCS7 Pressure–Displacement Response.....	81
112.	PCS7 Moment–Rotation Response.....	82
113.	PCS7-A Response.....	82
114.	PCS7-B Response	83
115.	PCS7-C Response	84
116.	PCS7 Panel Response (A, B, C)	84
117.	PCS8 Cross-Section Detail	85
118.	PCS8 Panel Detail.....	85
119.	PCS8 Pressure–Displacement Response.....	86
120.	PCS8 Moment–Rotation Response.....	87
121.	PCS8-A Response.....	87
122.	PCS8-B Response	88
123.	PCS8-C Response	89
124.	PCS8 Panel Response (A and C)	89
125.	PCS9 Cross-Section Detail	90
126.	PCS9 Panel Detail.....	90
127.	PCS9 Pressure–Displacement Response.....	91
128.	PCS9 Moment–Rotation Response.....	92
129.	PCS9-A Response.....	92
130.	PCS9-B Response	93
131.	PCS9-C Response	94
132.	PCS9 Panel Response (A, B, C)	94
133.	Tyn1 Cross-Section Detail.....	95
134.	Tyn1 Panel Detail	95
135.	Tyn1 Pressure–Displacement Response	96
136.	Tyn1-A Response.....	97

137.	Tyn1-B Response.....	97
138.	Tyn1-C Response.....	98
139.	Tyn2 Cross-Section Detail.....	98
140.	Tyn2 Panel Detail.....	99
141.	Tyn2 Pressure–Displacement Response.....	100
142.	Tyn2-A Response.....	100
143.	Tyn2-B Response.....	101
144.	Tyn2-C Response.....	101
146.	PCS10 Panel Detail.....	102
147.	PCS10 Pressure–Displacement Response.....	103
148.	PCS10 Moment–Rotation Response.....	104
149.	PCS10-A Inbound Response.....	104
150.	PCS10-B Rebound Response.....	105
151.	PCS10-A Inbound Response.....	105
152.	PCS10-B Rebound Response.....	106
153.	PCS11 Cross-Section Detail.....	107
154.	PCS 11 Panel Detail.....	107
155.	PCS11 Pressure–Displacement Response.....	108
156.	PCS11 Moment–Rotation Response.....	108
157.	PCS11-A Response.....	109
158.	PCS11-B Response.....	109
159.	PCS11 Panel Inbound Response (A).....	110
160.	PCS11 Panel Rebound Response (B).....	110
161.	PCD1 Cross-Section Detail.....	111
162.	PCD1 Panel Detail.....	111
163.	Coreslab Two-span Panel PCD1 Midspan Connection.....	112
164.	PCD1 Pressure–Displacement Response.....	113
165.	PCD1-A Response.....	113
166.	PCSD1-A Punching Failure of Connection.....	114
167.	PCD1-B Response.....	114
168.	PCD1-B Punching Failure of Connection.....	114
169.	PCD1-C Response.....	115
170.	PCD1-C Punching Failure of Connection.....	115
171.	PCD1-C Failure of Panel.....	116
172.	PCD2 Cross-Section Detail.....	116
173.	PCD2 Panel Detail.....	117
174.	PCD2 Midspan Connection Detail.....	117
175.	PCD2 Pressure–Displacement Response.....	118
176.	PCD2-A Response.....	119
177.	PCD2-B Response.....	120
178.	PCD2-C Response.....	121
179.	PCD2 Panel Response (A, B, C).....	122
180.	TS3-A, B Cross-Section Detail.....	122
181.	TS3-A, B Panel Detail.....	123
182.	TS3-A, B Connection Detail.....	123
183.	TS3-A, B Pressure–Displacement Response.....	124

184.	TS3-A Response	124
185.	TS3-B Response.....	125
186.	TS3 Panel Response (A, B)	125
187.	TS3-C, D Cross-Section Detail.....	126
188.	TS3-C, D Panel Detail	126
189.	TS3-C, D Connection Detail.....	127
190.	TS3-C, D Pressure–Displacement Response	128
191.	TS3-C Response.....	128
192.	TS3-D Response	129
193.	TS3 Panel Response (C, D)	129
194.	TS3-E, F Cross-Section Detail.....	129
195.	TS3-E, F Panel Detail	130
196.	TS3-E, F Connection Detail.....	130
197.	TS3-E, F Pressure–Displacement Response	131
198.	TS3-E Inbound Response	131
199.	TS3-F Rebound Response.....	132
200.	TS3 Panel Response (E, F)	132
201.	Average Single-span Tilt-Up Panels.....	133
202.	Average Single-span Response 3-2-3 Panels.....	134
203.	Average Single-span Response 3-2-3 Panels.....	134
204.	Average Single-span Response 3-4-3 Panels.....	135
205.	Average Computation	135
206.	Prestressed versus Non-PS Reinforcement.....	136
207.	Influence of Foam	137
208.	Pressure–Rotation Characterization (1 psi = 6.9kPa)	138
209.	Backbone Development	139
210.	Backbone with Optimum Constants (1 psi = 6.9 kPa).....	139
211.	Reinforced Backbones	140
212.	Prestressed Backbones	140
213.	Two-span Sections	142
214.	Measured Responses	143
215.	Backbone Curves	144

LIST OF TABLES

Table	Page
1. Damage Level Definitions [PDC 2008].....	3
2. Insulation Properties [PCI 1997]	7
3. PCI Static Single-span Specimen Matrix.....	10
4. Single-span Specimen Sections	14
5. Two-span Specimen Matrix.....	18
6. As-built Reinforcement Locations.....	30
7. Material Limits.....	34
8. Mill Certified Reinforcement Properties of Specimens.....	34
9. Concrete Batching Properties of Specimens.....	35
10. Concrete Compressive Strength of Specimen [psi]	36
11. As-built Concrete Tensile Properties	36
12. Single-span Fabrication Summary	37
13. Single-span Results Summary	38
14. TS1 Material Properties	39
15. TS1 Measured Response	40
16. TS2 Material Properties	43
17. TS2 Measured Response.....	43
18. PCS1 Measured Response	47
19. PCS2 Measured Response	50
20. PCS3 Measured Response	55
21. PCS3 (Type 2) Measured Response	60
22. PCS4 Material Properties.....	65
23. PCS4 Measured Response	65
24. PCS5 Measured Response	71
25. PCS6 Measured Response	76
26. PCS7 Measured Response	81
27. PCS8 Measured Response	86
28. PCS9 Measured Response	91
29. Tyn1 Measured Response.....	96
30. Tyn2 Measured Response.....	100
31. PCS10 Measured Response	103
32. PCS11 Measured Response	108
33. PCD1 Materials Properties	112
34. PCD1 Measured Response.....	112
35. PCD2 Measured Response.....	118
36. TS3-A and B Measured Response	124
37. TS3-C and D Measured Response	127
38. TS3-E and F Measured Response	130
39. Strength Estimates	138
40. Average Backbone Response of Single-span Panels	140
41. Average Rotation Capacity and Proposed Limits.....	141
42. Estimated and Actual Deformations	142
43. Multi-span Panel Response.....	144

1. INTRODUCTION

To comply with the energy efficiency and build green initiatives contained in the Energy Policy Act of 2005 and Energy Independence Security Act of 2007, the Anti-Terrorism and Force Protection (ATFP) requirements for building construction, and the “build it faster and more economical” requirements of the Military Construction Transformation initiative, a research program has been conducted by the Air Force Research Laboratory (AFRL) and the Portland Cement Association (PCA) on the performance of insulated concrete wall panels. The purpose of the research is to determine if commercially available wall systems with excellent energy savings performance can provide ATFP for military and government facilities.

The use of insulated precast/prestressed (PC/PS) concrete and insulated tilt-up concrete sandwich panels for exterior walls is common practice in the United States. These forms of construction provide a thermally efficient and high-mass wall that enhances the energy efficiency and blast resistance of the building making it ideal for military and government facilities. In most cases these building systems must be designed against a potential explosive demand. Current design recommendations are very restrictive when using these forms of construction, due in large part to the lack of experimental research data. To address this issue a research program has been conducted to assess the performance of conventional insulated exterior wall systems under blast loading. This report presents the static performance of the wall systems subjected to pseudo-blast pressures. The results indicate that sandwich wall systems provide blast resistance over a large deformation range making these systems useful for ATFP applications. The responses of the panels were found to be sensitive to reinforcement type, shear ties used, and insulation. Detailed discussions of the findings are presented in the conclusions of the report.

The information presented in this report represents the second phase of work under a Cooperative Research and Development Agreement (CRADA) entitled Blast Resistant Concrete Products. The CRADA is between PCA and the Airbase Technology Division of AFRL at Tyndall Air Force Base, Florida. Fabrication, design support, and product donations have also been provided from the Precast/Prestressed Concrete Institute (PCI), the Tilt-Up Concrete Association (TCA), and their member companies. Experiments were conducted and supervised by AFRL staff. National Center for Explosion Resistant Design at the University of Missouri-Columbia performed the static series discussed in this report.

2. OBJECTIVES

The overall research objective is to assess the inherent blast resistance of conventional insulated concrete sandwich wall (CSW) products. The research program is focused on developing models to predict the response of exterior building wall panels to explosive detonations at moderate standoff distances from the structure. In this research program wall systems are examined for each facet of the Portland Cement Association's membership. This includes PC/PS concrete wall panels (PPCWPs) for the PCI, tilt-up concrete wall panels for the TCA, masonry walls for the National Concrete Masonry Association, cast-in-place walls for the National Concrete Ready Mix Association, and insulated concrete wall panels for the Insulated Concrete Form Association.

For all concrete associations the objectives of the research are the same:

- Verify if conventional wall systems are capable of resisting a significant blast event.
- Identify if a wall system is capable of providing enough protection for temporary operation and/or continued function after a blast event.
- Develop predictive models for estimating the response of wall panels subjected to exterior blast generated pressure demands.
- Determine recommendations for acceptable deformation, rotation, and ductility limits for the wall panels examined.

This report examines the research objectives as they apply to PPCWPs. A series of quasi-static uniform loading experiments were conducted on standard PCI and TCA sandwich wall panels. The results of the experiments are used to model the resistance and deformation response of PPCWPs. Forty-six single-span walls and 12 two-span walls were examined. This project report provides details of the static test specimens, test configuration, results and comparative response.

The initial static test series is used to define the resistance and failure mode of standard commercially available designs for PC/PS concrete and tilt-up CSWs. The fundamental test results provide the necessary data to evaluate current static resistance functions and dynamic performance limits for sandwich walls constructed using different types of insulation, wythe connections, levels of composite action, and construction techniques. Ultimately, the results will provide valuable information for PCI/TCA program finite element models and lead to new design documentation and engineering level predictive tools for blast resistant sandwich concrete walls. These results will also be considered in providing guidance for designing government and military structures for ATFP standards using PCI/TCA construction methods.

2.1. Wall Performance Criteria

The experimental program results will be compared with current recommendations on wall performance and response. The performance of wall panels under blast demands are based on the level of damage achieved. These levels are associated with either displacement ductility or support rotation. For a uniformly loaded simply supported wall system the displacement ductility, μ , is defined as the displacement at midspan, Δ_{mid} , divided by the yield displacement, $\Delta_{\text{y-mid}}$, of the panel.

$$\mu = \Delta_{\text{mid}} / \Delta_{\text{y-mid}} \quad (1)$$

The support rotation, θ , for a simply supported system is directly related to Δ_{mid} , using the following formulation

$$\theta = \tan^{-1}[\Delta_{mid}/(L/2)] \quad (2)$$

where L is defined as the span length. It is important to note that the support rotation limits are not placed on the system as a means of checking the rotation capability of the supports. Instead the criterion is used to assess the midspan response relative to the span. Under this method long-span panels have a greater allowable midspan displacement than a short-span panel.

The response of the panel is categorized based on the amount of damage in the system as a result of the blast demand. The allowable damage for a given threat is determined based on the use of the facility and/or the performance levels established by the owner. The building is rated based on the level of protection (LOP) provided. The protection is divided into High, Medium, Low, Very Low, and Below Anti-Terrorism Standards. The LOP are in turn determined based on the damage level of the building components. The component damage levels are determined in accordance with the descriptions in Table 1 as developed by the Protective Design Center (PDC) of the US Army Corp [PDC 2008]. Insulated sandwich wall panels are considered a non-structural component. These panels are non-load bearing and their loss would have little effect on the overall structural stability of the building in the area of loss. Consequently the Building

Table 1. Damage Level Definitions [PDC 2008]

Component Damage Level	Description of Component Damage	Building Level of Protection	Limit for Reinforced Concrete Element in Flexure w/ No Shear Reinforcement and w/o Tension Membrane	Limit for Prestressed Concrete Element in Flexure w/o Tension Membrane and Reinforcement Index, $\omega_p^1 < 0.15$
Superficial Damage	Component has no visible permanent damage	High	$\mu \leq 1.0$	$\mu \leq 1.0$
Moderate Damage	Component has some permanent deflection. It is generally repairable, if necessary, although replacement may be more economical and aesthetic	Medium	$\mu > 1.0$ $\theta \leq 2.0^\circ$	$\mu > 1.0$ $\theta \leq 1.0^\circ$
Heavy Damage	Component has not failed, but it has significant permanent deflections causing it to be unrepairable	Low	$2.0^\circ < \theta \leq 5.0^\circ$	$1.0^\circ < \theta \leq 2.0^\circ$
Hazardous Failure	Component has failed, and debris velocities range from insignificant to very significant	Very Low	$5.0^\circ < \theta \leq 10.0^\circ$	$2.0^\circ < \theta \leq 3.0^\circ$
Blowout	Component is overwhelmed by the blast load, causing debris with significant velocities	Below Anti Terrorism Standards	$\theta > 10.0^\circ$	$\theta > 3.0^\circ$

¹Prestressed reinforcement index, $\omega_p = A_{ps}/bd_p(f_{ps}/f'_c)$

LOP and the Component Damage Levels are related as presented in Table 1.

The response limits for various levels of damage of PS and reinforced concrete (RC) flexural components are presented in Table 1. PS concrete components are considered to have limited ductility and, therefore, have lower response limits than non-PS or RC elements. For example a RC panel is considered to be at a Blowout Level at a rotation greater than 10° while a PS panel is at the same damage level at a rotation of 3°. The damage level descriptions and the response limits for each level are assessed as part of this research.

3. INSULATED SANDWICH WALLS

CSW panels are widely used across the United States for construction of building systems. These panels consist of an interior concrete section or “wythe,” a foam insulating layer, and an exterior concrete wythe as illustrated in Figure 1. The interior and exterior layers are connected to each other using shear ties. Varying the amount and type of shear ties allows the interior and exterior wythe to act at various levels of composite action.

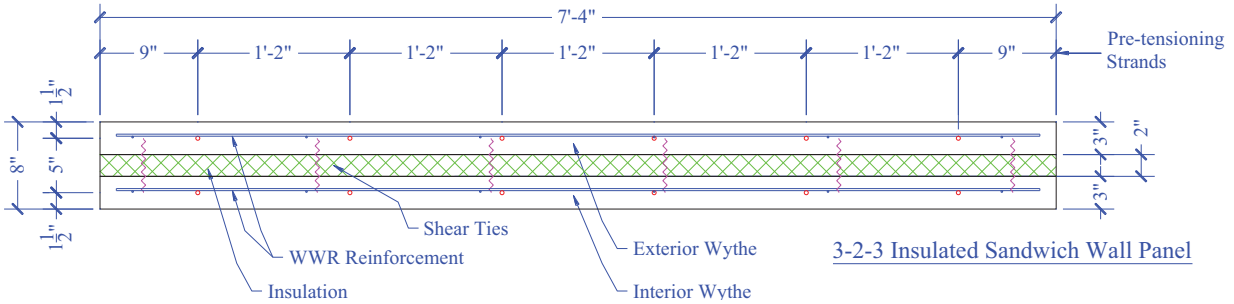

Figure 1. Sandwich Panel Cross-Section

Sandwich panels are produced using one of two methods. The first method is referred to as tilt-up construction method; the second is referred to as the PC/PS construction method. The tilt-up method consists of fabricating the panels on the construction site building floor slab or on a temporary casting slab adjacent to the building footprint. For this method steel reinforcement is tied and concrete is placed in the field in a horizontal position (Figure 2). When the panels reach an adequate strength, they are tilted upward into their final position and braced until the floor slabs are installed. This method of construction is used by the TCA. The second method, preferred by members of the PCI, involves prefabricating the wall panels off-site at a casting facility (Figure 3). The facilities are often environmentally controlled and have high quality control allowing for production of panels in all weather conditions. The fabrication at an off-site casting facility also allows the option of having the reinforcing steel to be pre-tensioned prior to placement of the concrete. This allows the panels to be prestressed in compression thus limiting the potential for cracking in transport or during the service life on the building. Both construction methods provide a building envelope that is energy efficient and quick to construct.



Figure 2. Tilt-up Concrete Sandwich Wall Construction [TCA 2006]



Figure 3. Prestressed Concrete Sandwich Wall Construction [PCI 1997]

PC wall panels are typically designed for wind loads and handling loads on the construction site. In most cases the design goal is to preclude cracking. As a consequence, sandwich panels are in most cases designed to be elastic under service loading.

CSWs provide an ideal option for US Government and military facility construction. The foam sandwich provides high levels of insulation resulting in an energy efficient building envelope. The panels can be detailed to achieve any thermal resistance R-value needed. The panels are prefabricated, allowing for rapid erection of the building and short construction schedules. The use of concrete provides a high inertial mass that enhances the blast resistance of the facility against external detonations. This last characteristic is essential for meeting the blast resistance requirements for federal and military facilities. Furthermore, while the thermal properties and construction quality has been well documented, minimal information has been generated on the performance of panels under blast demands. To quantify the blast resistance of these systems a comprehensive experimental program is conducted on insulated sandwich wall panel systems.

3.1. Sandwich Wall Configurations

Sandwich walls are available in a variety of forms. The TCA configurations typically consist of a 2.0-to-3.0-in exterior wythe, a 2.0-to-3.0-in foam layer, and a 6-in interior structural wythe. Since this type of construction is only tilted, and rarely transported on site, the walls are most often designed to be non-composite with minimal amount of shear ties used. Fully composite options are also available in TCA configurations. The interior wythe is designed to resist the prevailing wind demand requirements. A typical TCA wall section is illustrated in Figure 4b. PCI type walls come in a larger variety of configurations. They can consist of thin (3-in thick) interior and exterior wythes and a 2-in to 5-in thick foam insulating layer (Figure 4a) or a design utilizing hollow core (Figure 4c), double tees (Figure 4d), or other panels.

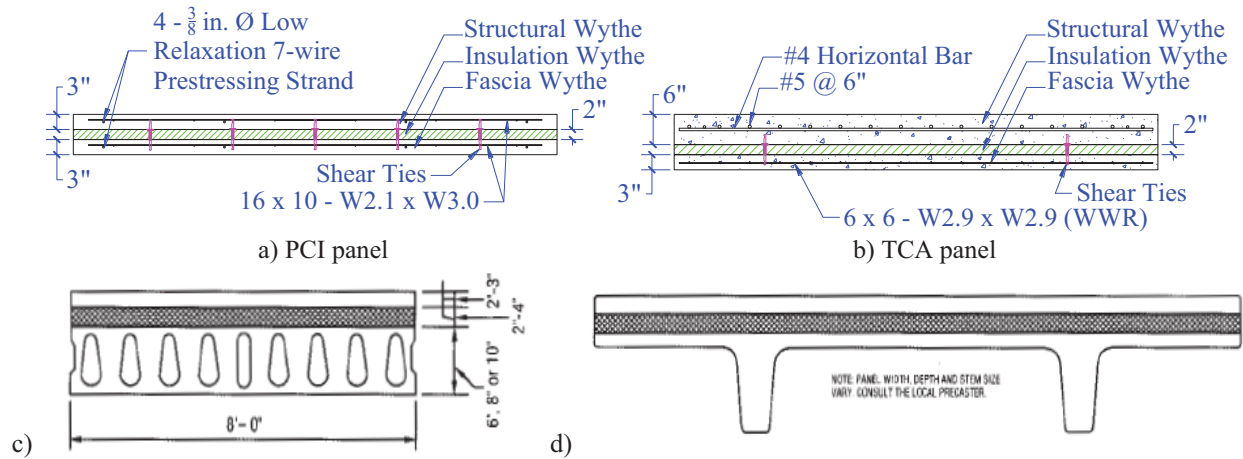

Figure 4. TCA and PCI Wall Sections (c and d [PCI 1997])

3.2. Insulation Foam Properties

Three standard types of insulation are commonly used in PC sandwich walls. They include expanded polystyrene (EPS), extruded expanded polystyrene (XPS [or XEPS]), and polyisocyanurate (PIMA). EPS is also known as bead board and is often used for low-cost coolers. XPS insulation is commonly produced by Dow or Owens Corning and is sold as Blue Board or Pink Board, respectively. Typical properties of these panel types are summarized in

Table 2. In general the cost, density, thermal resistance, and strength increase from EPS to XPS to PIMA. The insulation used in the research program met the requirements of American Society for Testing and Materials (ASTM) C578 Standard Specification for Rigid, Cellular Polystyrene Thermal Insulation [ASTM 2009a].

Table 2. Insulation Properties [PCI 1997]

Physical Property	Polystyrene						Polyisocyanurate	
	Expanded			Extruded			Unfaced	Faced
Density (lb/ft ³)	0.7–0.9	1.1–1.4	1.8	1.3–1.6	1.8–2.2	3.0	2.0–6.0	2.0–6.0
Water absorption (percent volume)	< 4.0	< 3.0	< 2.0	< 0.3			< 3.0	1.0–2.0
Compressive strength (psi)	5–10	13–15	25	15–25	40–60	100	16–50	16
Tensile strength (psi)	18–25			25	50	105	45–140	500
Linear coefficient of expansion (in/in/°F) x 10 ⁶	25–40			25–40			30–60	
Shear strength (psi)	20–35			--	35	70	20–100	
Flexural strength (psi)	10–25	30–40	50	40–50	60–75	100	50–210	40–50
Thermal conductivity (Btu-in/hr/ft ² /°F)	0.30	0.26	0.23	0.20			0.18	0.10–0.15
Maximum use temperature	165 °F			165 °F			250 °F	

3.2.1. Shear Tie Types

Five types of shear ties were examined: C-Grid®, THERMOMASS® composite and non-composite ties, and standard stainless steel C-clips. C-Grid® consists of a carbon fiber mesh placed between the interior and exterior wythe. The proprietary C-Grid® carbon fiber reinforced polymer is produced by Carbon Cast. THERMOMASS® Composite Pins were also examined. These pins consist of glass fiber ties installed between the interior and exterior wythe at a 16-in spacing over the surface of the wall. A standard stainless steel C-clip was also examined to provide a baseline comparison. The ties used in the research program were compared to other connector types available in the US market in Figure 5. Shear Ties Samples

: (A) THERMOMASS® non-Composite Tie, (B) THERMOMASS® Composite Tie, (C) Universal Teplo Tie, (D) Dayton Superior Delta Tie, (E) Carbon Cast C-Grid®, (F) Standard Steel C-Clip, and (G) Meadow Burke Steel Welded Wire Girder. The strength and stiffness of these ties and additional tie systems were experimentally determined in an earlier phase of the research and are summarized in AFRL Report AFRL-RX-TY-TR-2009-4600.

Carbon and glass fiber ties were used in the program to represent thermal efficient construction. Steel ties are widely available; however, they create a thermal bridge between the exterior and interior faces of the panel. This results in reduced insulation properties and greater heat transmittance. For example, metal ties spaced at 16 in on center have been shown to increase the heat transmittance of a sandwich wall panel by over 20% [PCI 2004]. This increase can produce cold spots on a wall panel that can produce unsightly condensation. The high thermal transmittance also decreases the insulation capability of the wall which increases heating and cooling costs for the structure. The carbon and glass ties do not produce a significant thermal bridge; however, they are available only as proprietary systems. Consequently, the proprietary systems were used in the research program.

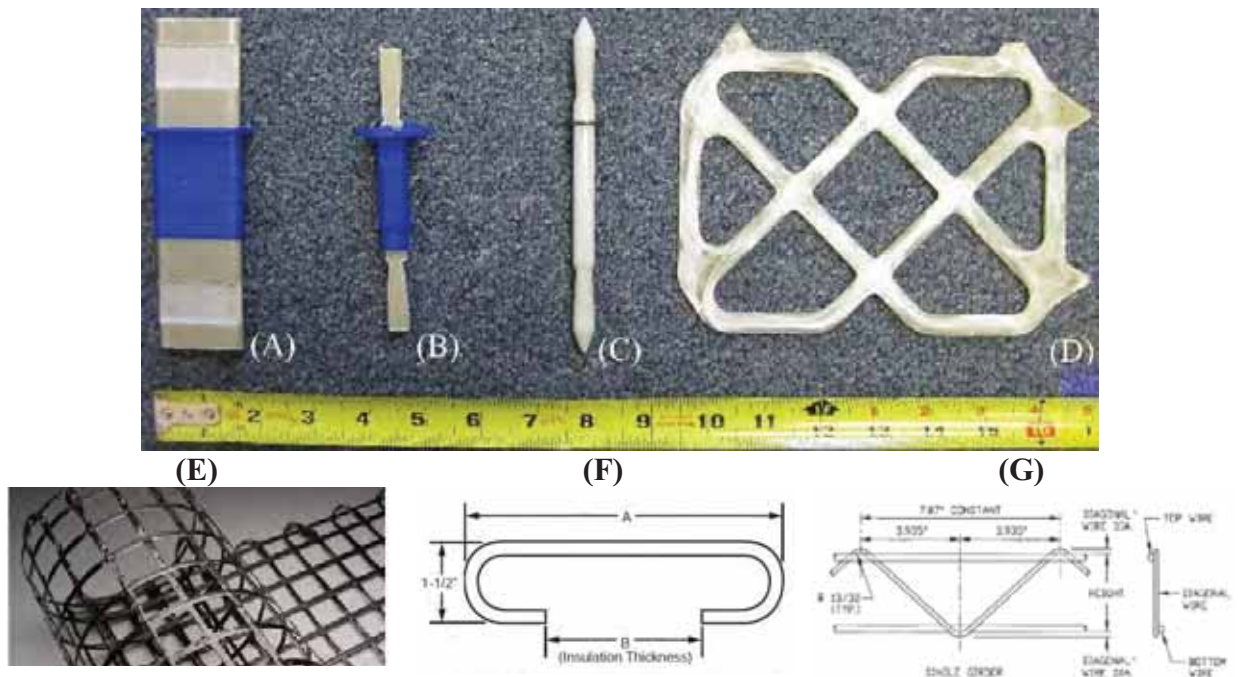

Figure 5. Shear Ties Samples

4. DETAILS OF STATIC SPECIMENS

The research program examined the performance of two construction methods. The first method followed the practice of the TCA, the second method followed the practice of the PCI. The panel types were divided into three general configurations: Non-composite non-prestressed walls with an interior structural wythe and a exterior fascia wythe (TCA), partially composite non-prestressed walls (TCA and PCI), and partially composite prestressed walls (PCI). The details are presented with respect to the test type. Three experimental series were conducted:

- Single-span panels with idealized supports
- Multi-span panels with intermediate connections
- Single-span panels with end connections

4.1. Single-span Panels with Idealized Supports

A total of 42 single-span specimens with idealized simple supports were examined. Two details typical of tilt-up construction, TS1 and TS2, and 12 details typical of PC/PS concrete construction, PCS1 through PCS9 and PCS3 Type2, were examined. For each detail, three tests were conducted to assess repeatability of the data generated. The three tests for each panel type were designated with A, B and C shear ties. The comprehensive matrix of single-span specimens is summarized in Table 3. Panels were produced by the TCA members and two PCI certified producers, Metromont Corporation and Coreslab Structures. The wythe configuration, insulation material, reinforcement and ties used in each panel are also defined in Table 3.

To develop the experimental subassemblies, PCI and TCA groups were tasked to design wall panels to the following requirements:

- Panel Width = 8 ft
- Panel Length = 24 ft
- Two span with intermediate support at mid-height
- Non-load bearing
- Stripping: Use two-point pick points at one-fifth points from ends and sides of panel
- Erection: Use three-point pick with lower points at 4 ft and 14 ft from lower end of the panel
- Design wind speed 110 mph, exposure C, enclosed building
- Wind Loads computed in accordance with ASCE 7-05
- Panels designed in accordance with American Concrete Institute (ACI) 318-08
- No blast design criteria included
- Occupancy Category IV
- If used, all prestressing shall be 3/8-in diameter grade 270 low relaxation

The wall designs were sectioned to evaluate tributary widths of 16 in for the TCA panels and 32 in for the PCI panels. These thin widths were chosen based on the longitudinal reinforcement and shear ties spacing. In addition, the narrow widths facilitated handling and laboratory testing.

Table 3. PCI Static Single-span Specimen Matrix

No.	Specimen	Wythe Config.	Insulation	Panel Reinforcement (Longitudinal / Transverse)	Composite Ties	Fabricator
1-3	TS1-A,B,C	6-2-3	XPS	#3 bar/ WWR	THERMOMASS® - Non-Composite	TCA
4-6	TS2-A,B,C	3-2-3		#3 bar/ #3 bar	THERMOMASS® - Composite	
7-9	PCS1-A,B,C	3-2-3	EPS	3/8Ø strand / WWR	Steel C-clip	Metromont
10-12	PCS2-A,B,C			3/8Ø strand / WWR	C-Grid®	
13-15	PCS3-A,B,C			#5 bar/ WWR	C-Grid®	
16-18	PCS3 (Type 2)-D, E, F			3/8Ø strand & #5 / WWR	C-Grid®	
19-21	PCS4-A,B,C	3-3-3	XPS	3/8Ø strand / #3 bar	Steel C-clip	Coreslab
22-24	PCS5-A,B,C			3/8Ø strand / #3 bar	THERMOMASS® Composite	
25-27	PCS6-A,B,C			3/8Ø strand / WWR	C-Grid®	Metromont
28-30	PCS7-A,B,C		PIMA	#5 bar/ #3 bar	THERMOMASS® Composite	Coreslab
31-33	PCS8-A,B,C			3/8Ø strand / #3 bar		
34-36	PCS9-A,B,C			3/8Ø strand / WWR	C-Grid®	Metromont
37-39	Tyn1A,B,C	3-4-3	XPS	3/8Ø strand / #3 bar (bonded)	Meadow Burke Wire Girder MB-343-7	Tyndall
40-42	Tyn2 A,B,C			3/8Ø strand / #3 bar (unbonded)	Meadow Burke Wire Girder MB-343-7	

Two prototype panels were designed by TCA. The details are shown in Figure 6 and Figure 7. The

3-2-3 wall is designed to be partially composite and relies on the use of THERMOMASS® Composite ties. The 6-2-3 wall is designed to be non-composite with the 6-in section acting as the structural wythe and Non-Composite THERMOMASS® ties providing the connection to the fascia wythe.

To preserve symmetry in the static samples, the longitudinal rebar size and spacing was changed from the prototype walls provided by TCA. In addition, due to handling concerns, the cross section width was reduced to 16 in. The specimens were detailed to have one line of THERMOMASS® connectors and two longitudinal reinforcing bars. The spacing and size of the longitudinal reinforcement was chosen to provide the same flexural strength as the prototype panels. Conventional lifting hardware was not used due to the small size of the specimen. Instead reinforcement hooks were included to assist in handling. The schematics of the single-span static specimens are illustrated in Figure 8 and Figure 9.

A similar procedure was conducted for PCI panels. The prototype panels developed by two of the PCI manufacturers, Metromont Corporation and Coreslab Structures, are illustrated in Figure 10 and Figure 11. Metromont designed a 3-2-3 configuration while Coreslab designed a 3-3-3 configuration. The specimens were detailed to have a similar flexural strength per width as the prototype panels. A wide variety of sandwich panel details were developed from the prototypes illustrated in Table 4.

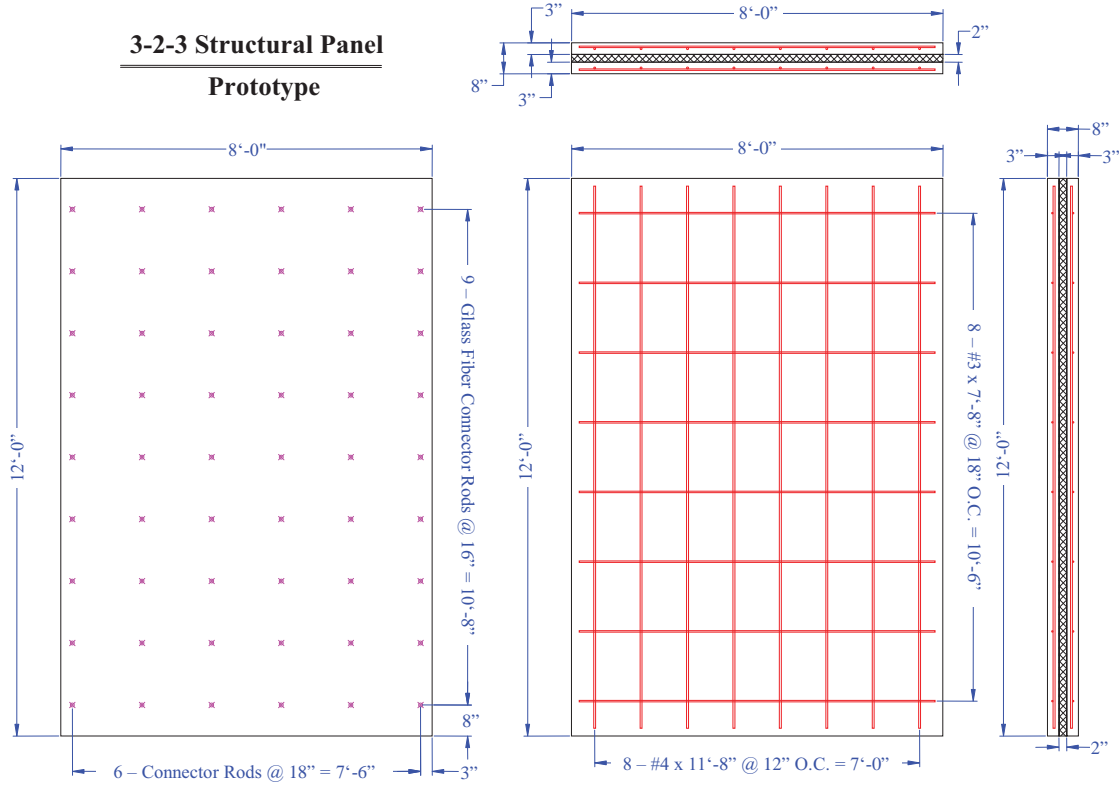

Figure 6. Prototype TCA 3-2-3 Wall

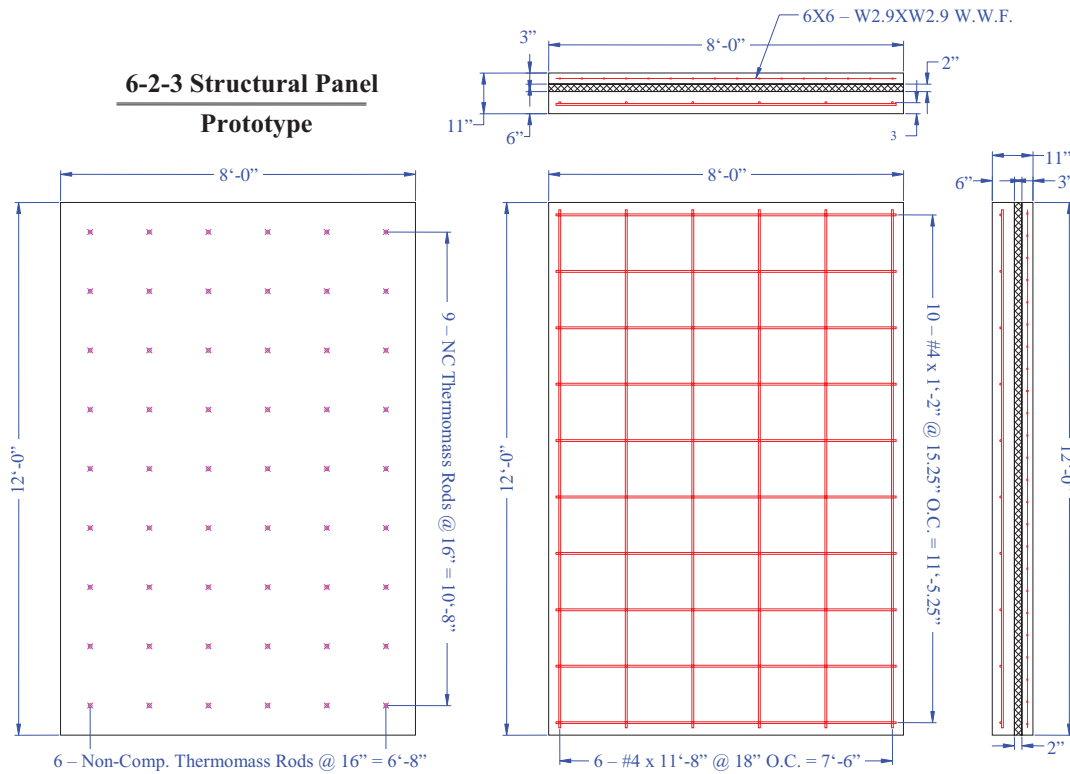

Figure 7. Prototype TCA 6-2-3 Wall

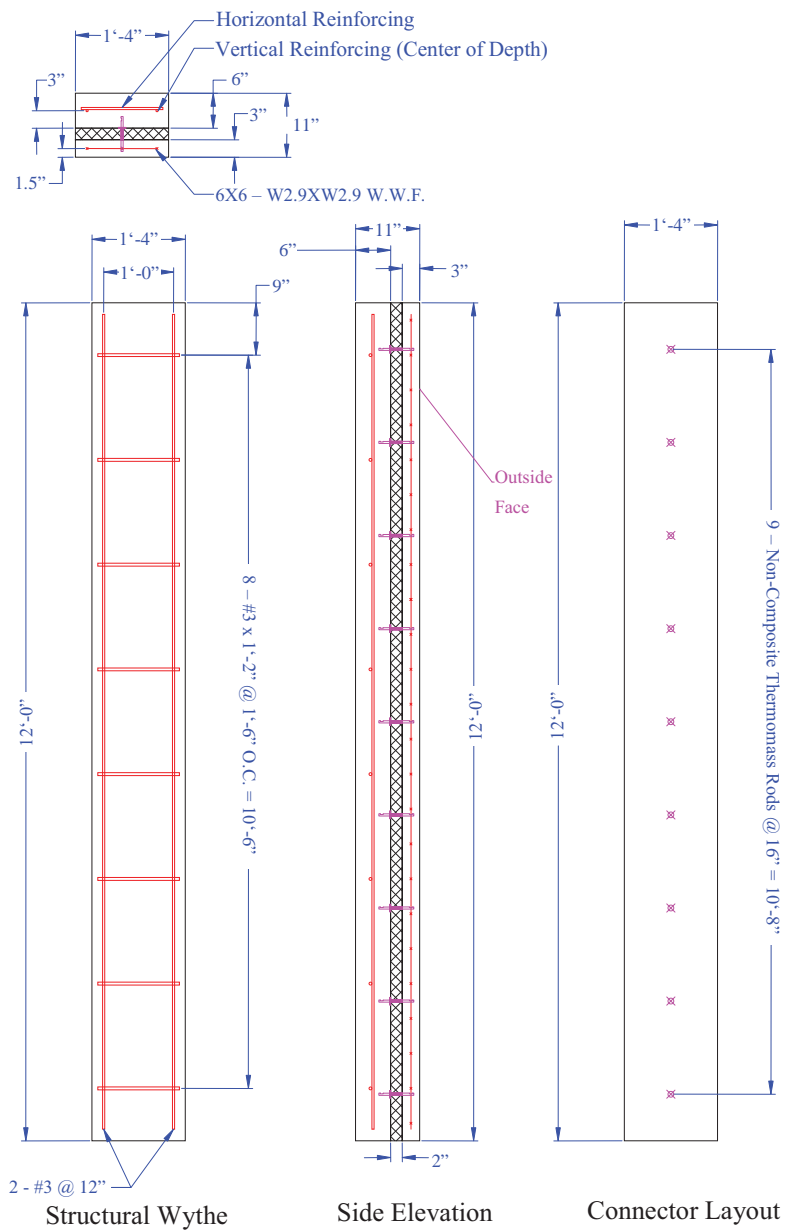

Figure 8. TCA Non-composite 6-2-3 Single-span Static Specimen TS1 Details

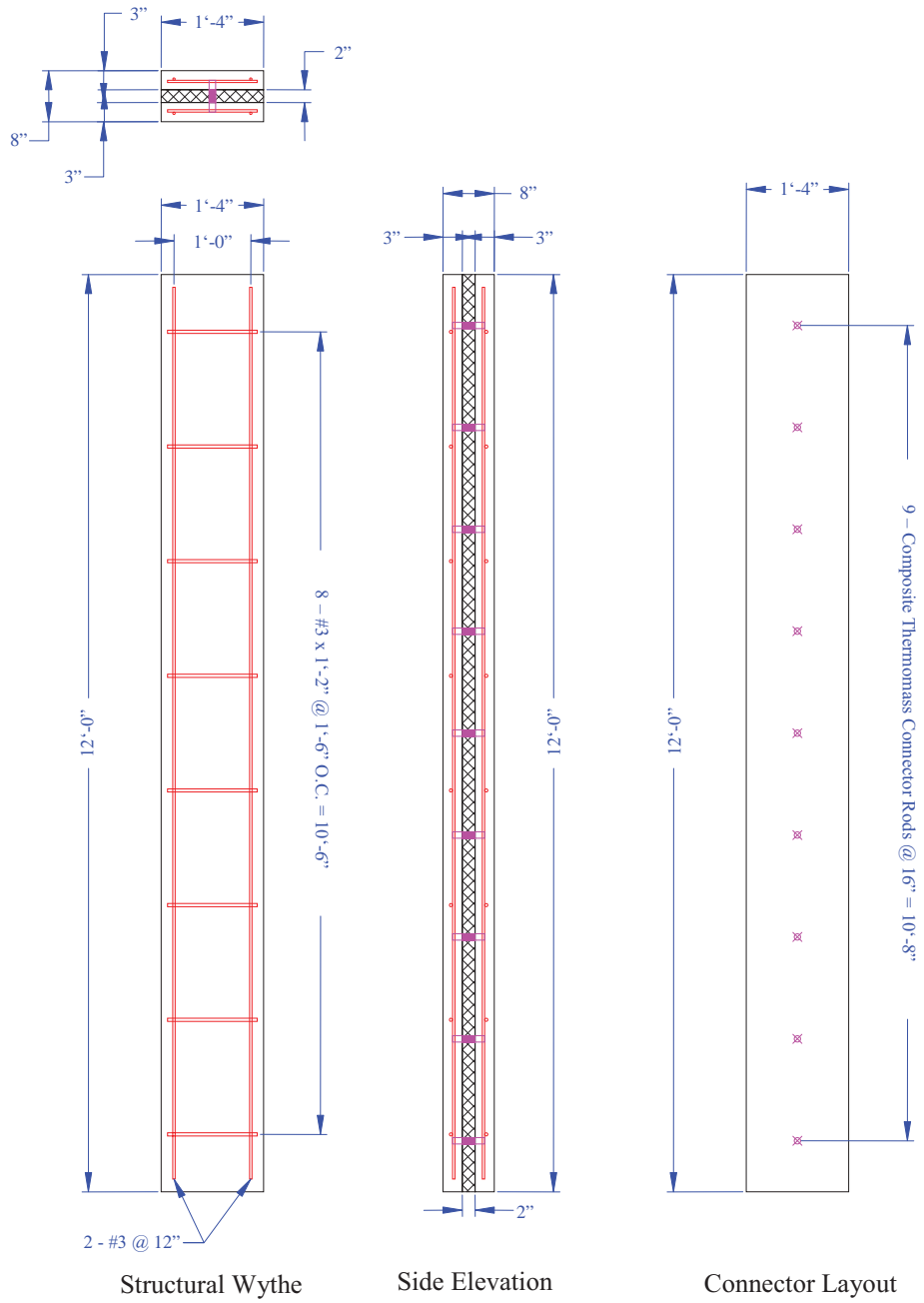
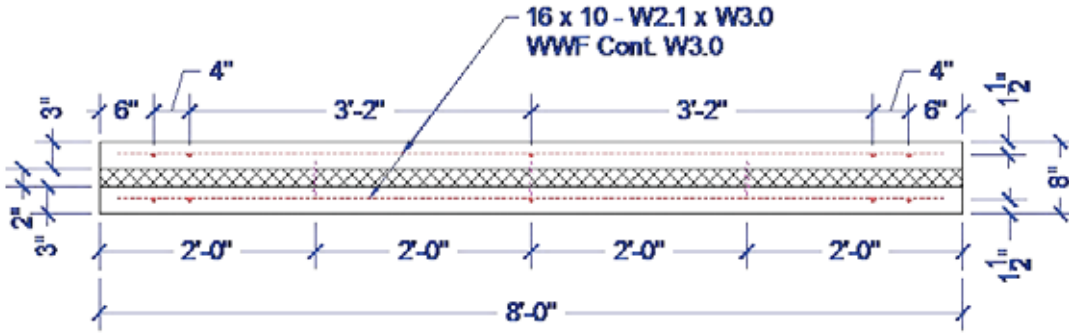

Figure 9. TCA Composite 3-2-3 Single-span Static Specimen TS2 Details



USE (10) $\frac{3}{8}$ - in \emptyset 270 ksi Low Lax Strand @ 17,200 # I.T.
 USE 5000 psi Concrete at 28 Days Minimum
 Release @ 3500 psi Minimum Strength

Figure 10. Metromont PCI Prototype Wall Panel Design

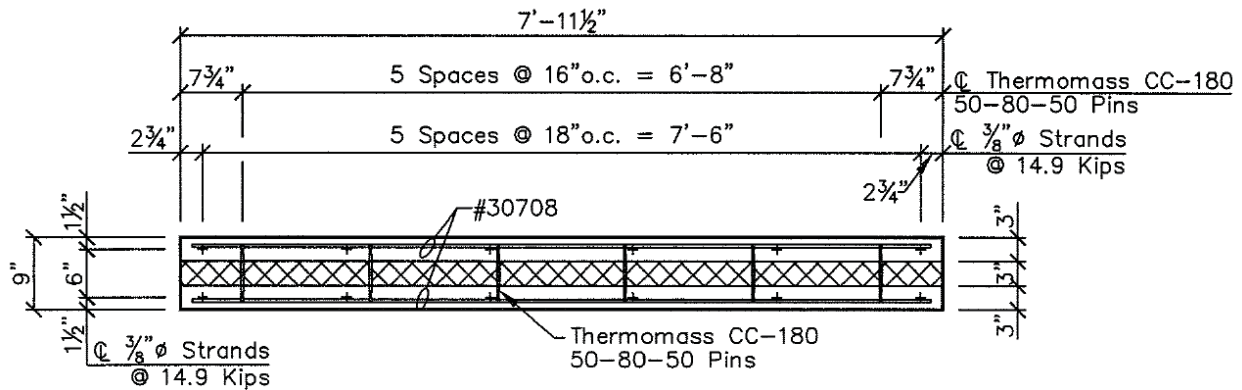
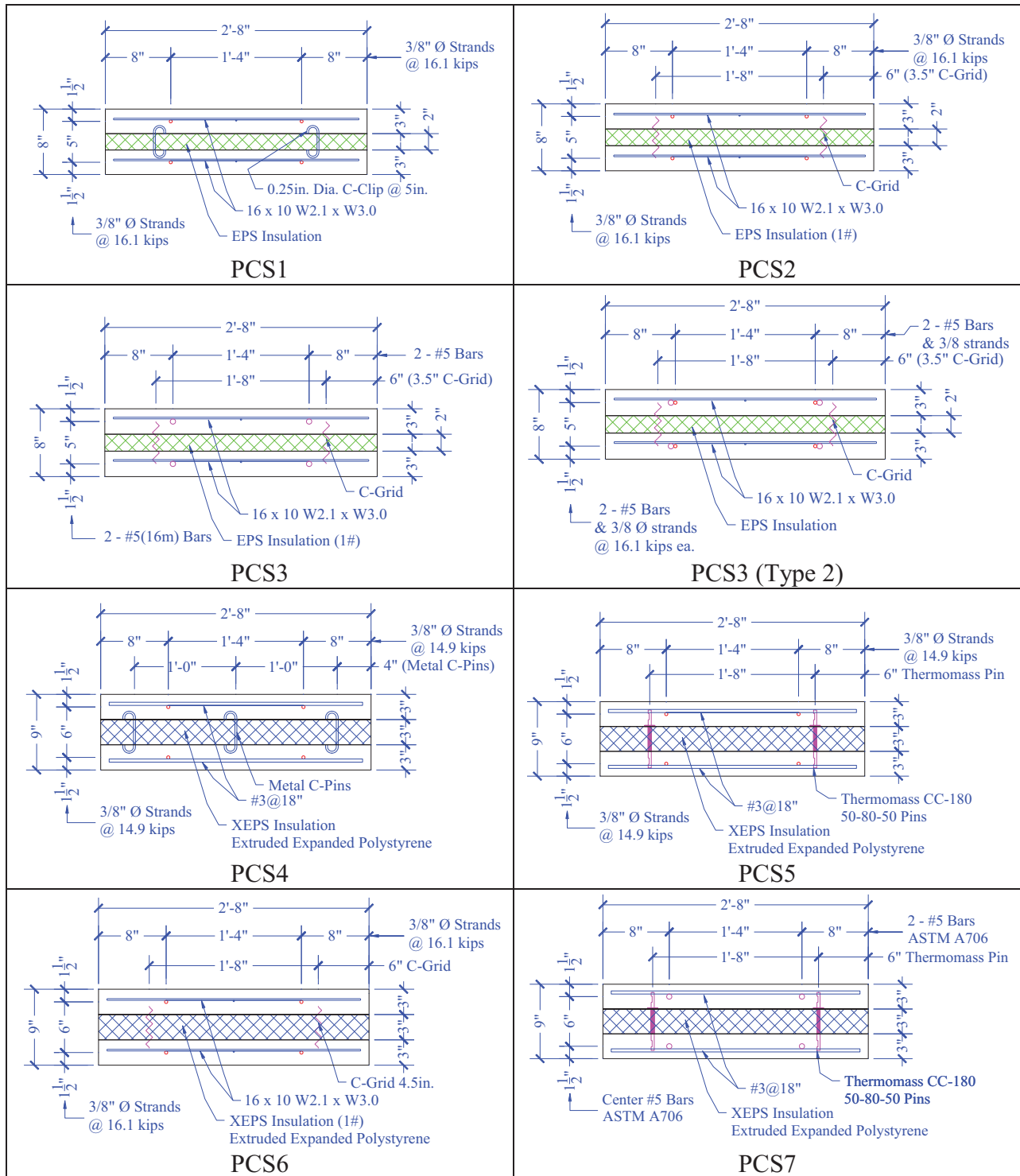

Figure 11. Coreslab PCI Prototype Wall Panel Design

The experimental specimen details are summarized in Table 4. The cross-section dimension and the reinforcement and shear tie properties for each panel type are given.

Table 4. Single-span Specimen Sections

Specimen	Reinforcement and Tie Details
TS1	<ul style="list-style-type: none"> #3 @ 18 in. Transverse Reinforcement #3 Longitudinal Reinforcement 6 x 6 W2.9 x W2.9 THERMOMASS Non-Composite Tie XPS Insulation Expanded Extruded Polystyrene
TS2	<ul style="list-style-type: none"> #3 @ 18 in. Transverse Reinforcement #3 Longitudinal Reinforcement #3 Longitudinal Reinforcement THERMOMASS Composite Tie XPS Insulation Expanded Extruded Polystyrene



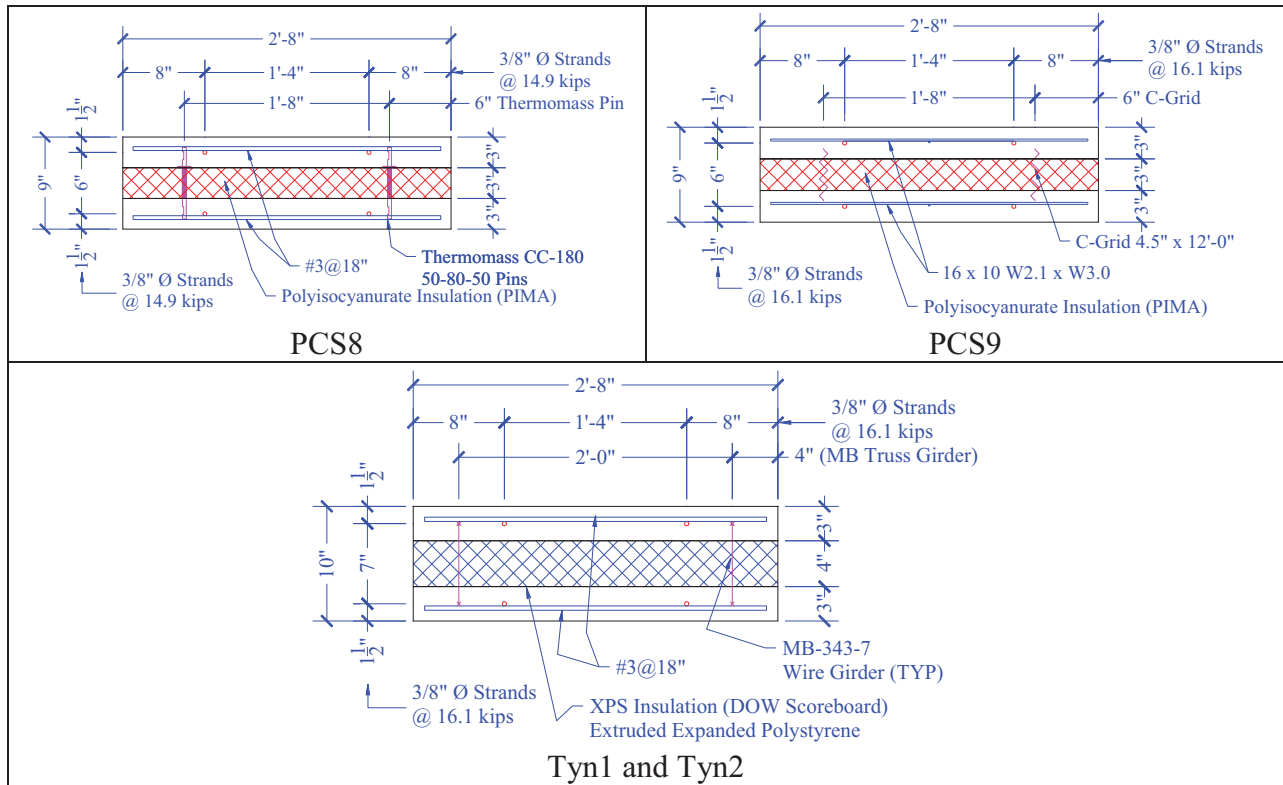

Four combinations of longitudinal and transverse reinforcement were used for the PCI panels. The Metromont panels used welded wire reinforcement (WWR) for transverse reinforcement while the Coreslab and Tyndall panels used #3 bars. In addition, two non-PS panels were included: PCS7 and PCS3. For these panels the non-prestressed reinforcement consisting of four #5 bars were used in place of the four 3/8-in diameter prestressing strands. This reinforcement quantity resulted in a comparable ultimate moment capacity between the specimen. The transverse reinforcement layout for the four PCI panel types are illustrated in Figure 12 and Figure 13. Further details of each specimen appear in the results section of the report.

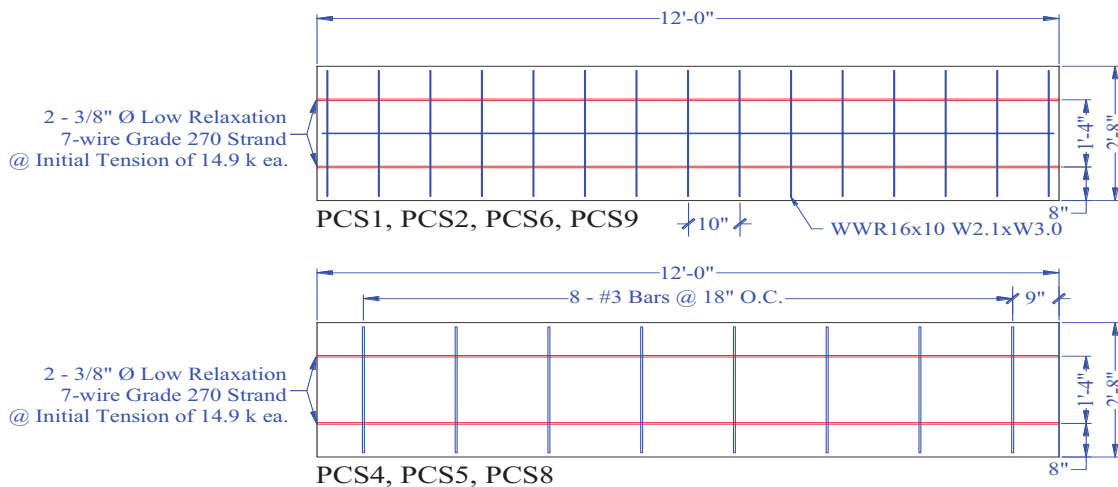

Figure 12. PCI Panel Reinforcement

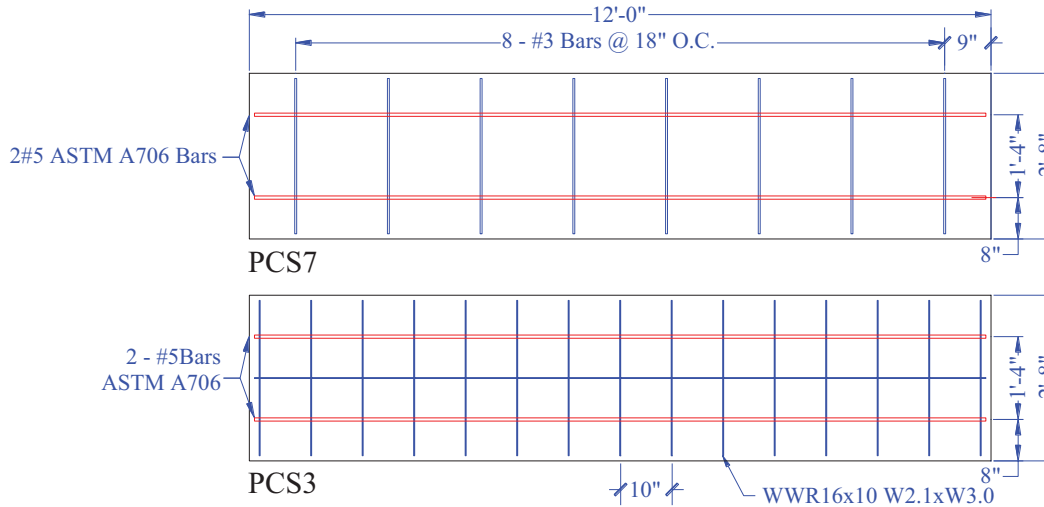

Figure 13. Control Panel Reinforcement

Specimens Tyndall 1 and Tyndall 2 modeled the effectiveness of unbonded reinforcement in enhancing the flexural deformation capacity of sandwich panels. The specimen details are illustrated in Figure 14.

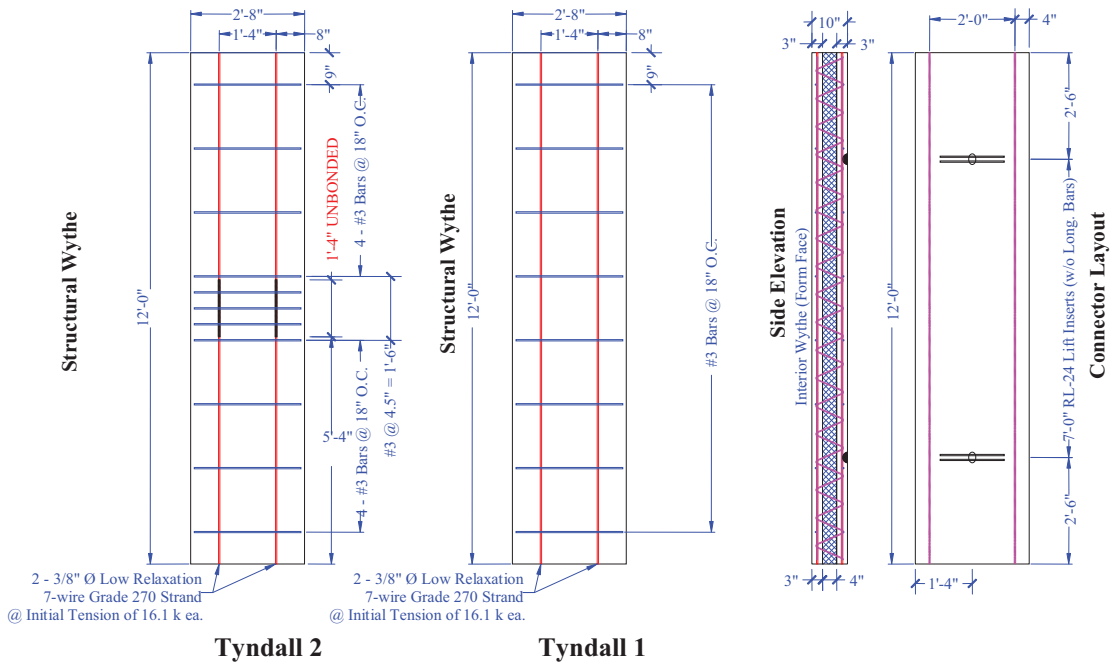

Figure 14. Tyndall Panel Reinforcement

4.2. Multi-span Panels with Intermediate Connections

Five two-span details were examined. These details were chosen to match the standard Tilt-Up Construction and standard Prestressed/Precast Concrete Industry designs. Three TCA type details and two PCI details were examined. Two of each type of TCA detail were tested. These

specimens are identified as TS3-A and B, TS3-C and D, and TS3-E and F. Three of each type of PCI detail were tested. These specimens are identified as PCD1-A, -B, and -C, and PCD2-A, -B, and -C. The matrix of two-span specimens is summarized in Table 5. Details of each specimen are included in Figure 15-Figure 19.

Table 5. Two-span Specimen Matrix

Specimen	Wythe Config.	Insulation	Panel Reinforcement	Composite Ties	Connector
PCD1-A	3-3-3	XPS	Prestressed / Rebar	THERMOMASS® Composite	Stud Group
PCD1-B					
PCD1-C					
PCD2-A	3-2-3	EPS	Prestressed / WWR	C-Grid®	Stud Group
PCD2-B					
PCD2-C					
TS3-A	6-2-3	XPS	Reinforced Concrete	THERMOMASS® – Non-Composite	Halfen Connector
TS3-B					No Connector
TS3-C					
TS3-D					
TS3-E					
TS3-F					Stud Group

4.2.1. Midspan Connection Details

The recommended details for the midspan connection on the two-span panels are described in this section. A standard roller consisting of a pipe bearing on the panel was used for the end connection of each panel. The sliding Halfen connection used in specimen TS3 consisted of a HT5506 connector as illustrated in Figure 20 and Figure 21. This connection is a proprietary system produced by Meadow Burke. Similar connections are available from other vendors such as JVI as illustrated in Figure 22. The JVI connectors were not included in the test series.

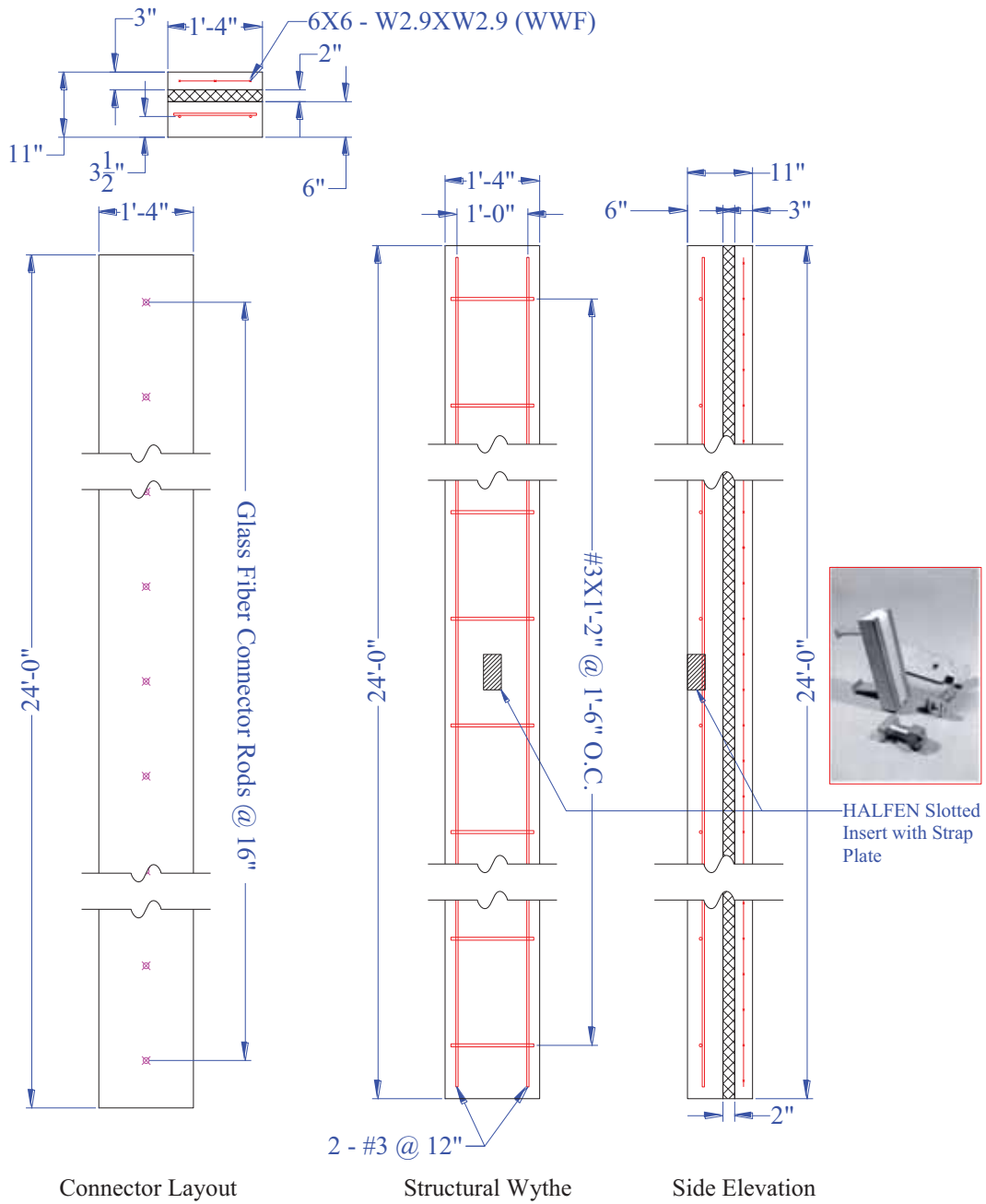

Figure 15. TCA Two-span Details TS3-A and B

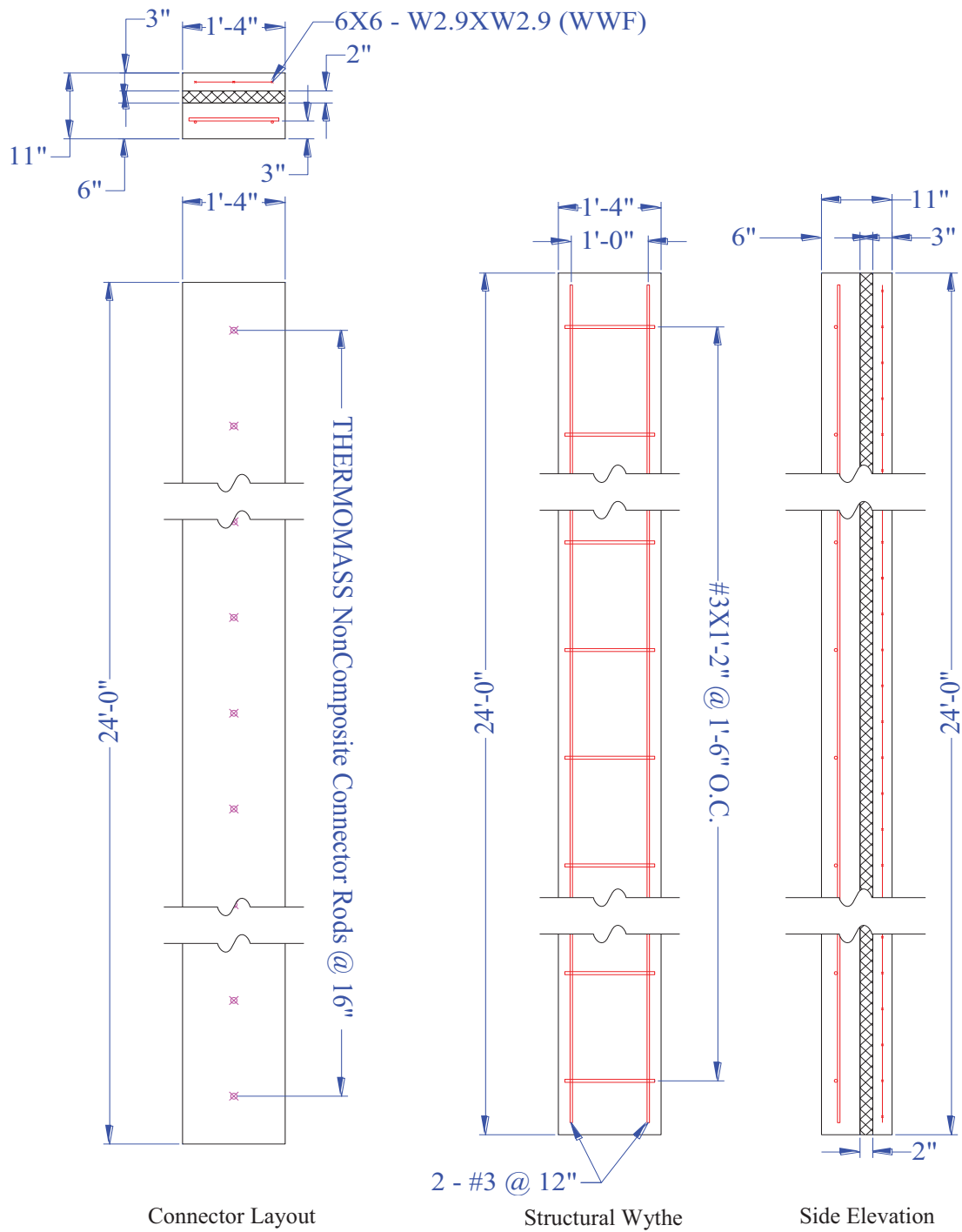

Figure 16. TCA Two-span Details TS3-C and D

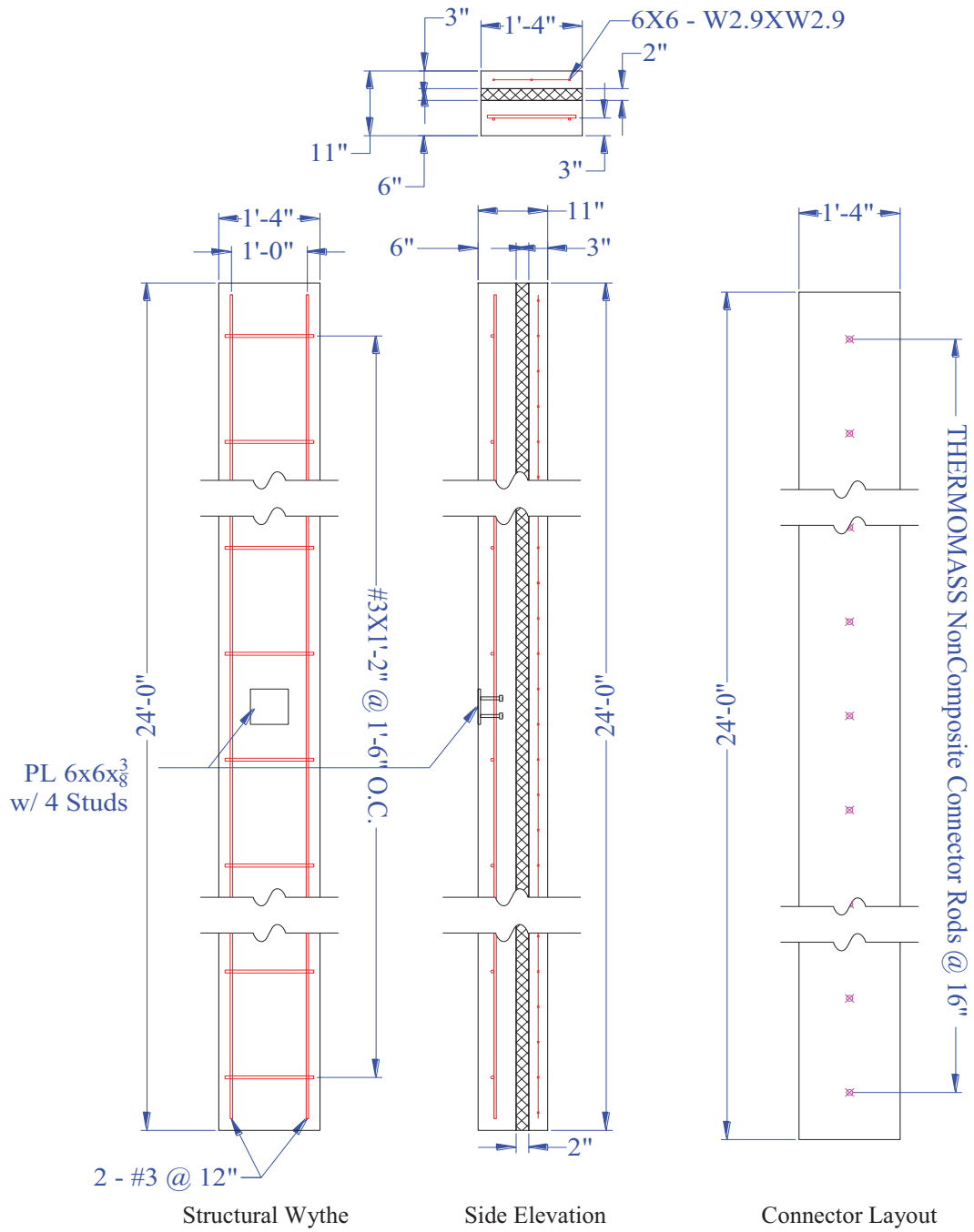

Figure 17. TCA Two-span Details TS3-E and F

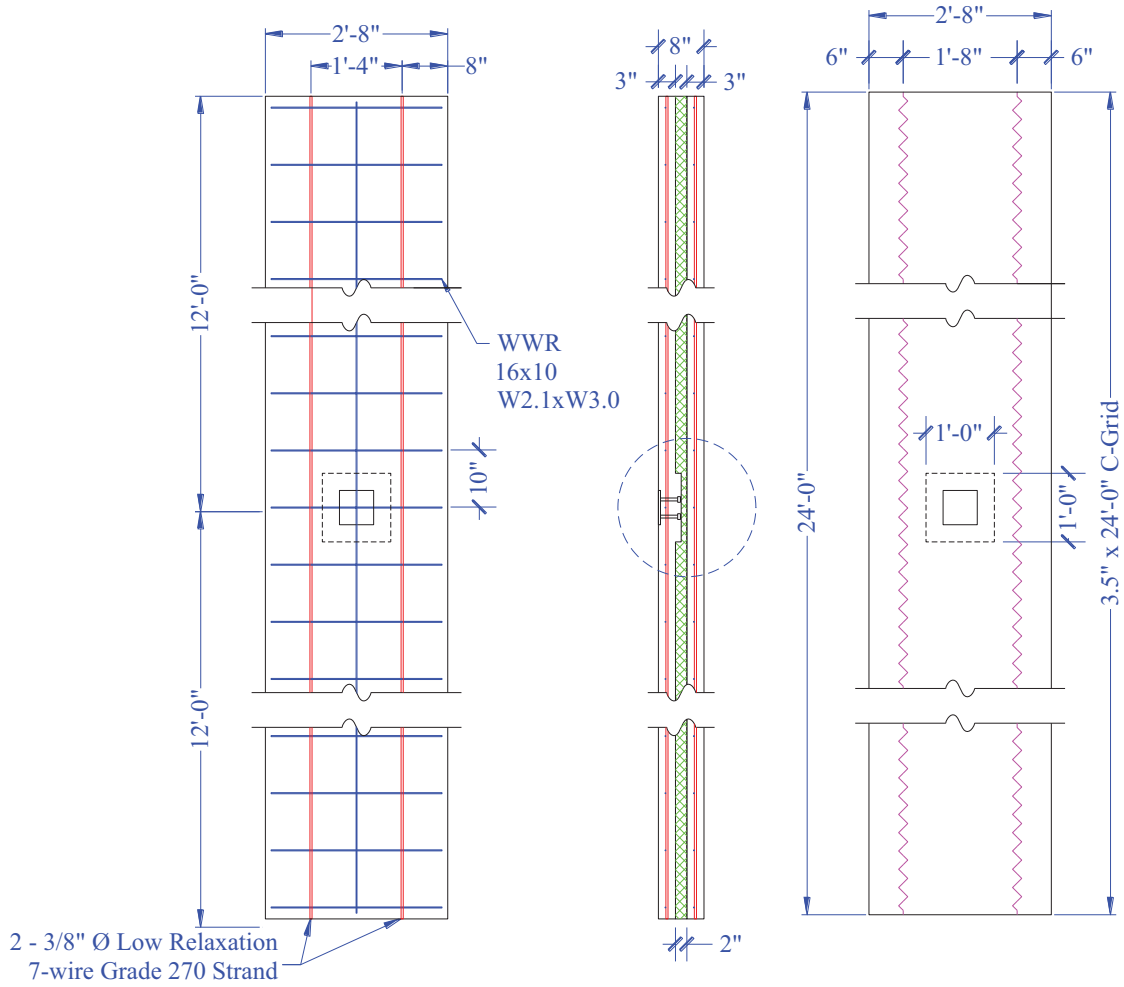

Figure 19. Metromont Two-span Panel PCD2

ANCHOR CHANNEL SELECTION CHART									
Anchor Channel	HDG Mill Finish	HT3506		HT4506		HT5506		HT6506 TA	
		HT3506 MF		HT4506 MF		HT5506 MF		HT6506 TAMF	
Load Direction		Pull-out	Shear	Pull-out	Shear	Pull-out	Shear	Pull-out	Shear
Ultimate Capacity	lb (kN)	6,650 (29.6)	7,560 (33.6)	7,500 (33.4)	11,300 (50.3)	11,250 (50.1)	11,950 (53.2)	21,200 (94.3)	20,050 (89.2)
Basic Design Load	lb (kN)	2,200 (9.8)	2,500 (11.1)	2,500 (11.1)	3,750 (16.7)	3,750 (16.7)	4,000 (17.8)	7,050 (31.4)	6,700 (29.8)
Wind Load	lb (kN)	2,900 (12.8)	2,500 (11.1)	3,300 (14.6)	3,750 (16.7)	5,000 (22.3)	4,000 (17.8)	7,050 (31.4)	6,700 (29.8)
Min. Distances	A in (mm)	3 (76)	3-1/2 (90)	3 (76)	4 (102)	4 (102)	5 (127)	5 (127)	8 (203)
	B in (mm)	2 (51)	2 (51)	2 (51)	2 (51)	3 (76)	3 (76)	4 (102)	4 (102)
	C in (mm)	1-1/2 (38)		1-9/16 (40)		2 (50)		2-1/16 (52)	
	D in (mm)	5/8 (17)		7/8 (22)		1-3/16 (30)		1-5/16 (34)	
	E in (mm)	3-1/16 (77)		3-1/4 (82)		3-1/2 (90)		5-1/4 (134)	

1 Panel Restraint Anchors can be supplied with I-anchor turned 90° to avoid conflict with prestressing tendon, specify "Type L" when ordering.
 2 Table is based on 5,000 psi unreinforced, normal weight concrete and a 3:1 safety factor.

MBS MeadowBurke

Halfen Anchoring System

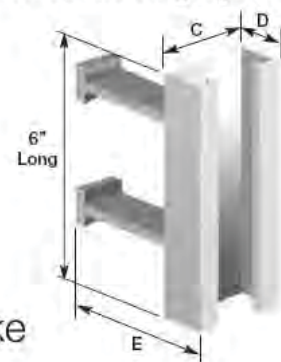

Figure 20. MeadowBurke Halfen Insert Capacity [Meadow Burke 2011]

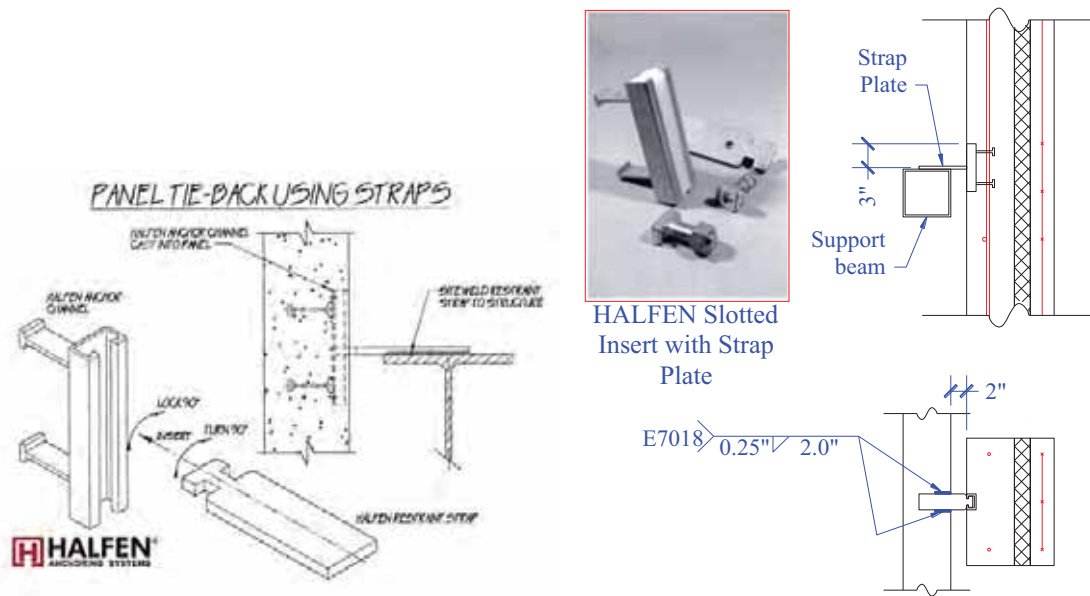

Figure 21. TS3-A and B Connection Details

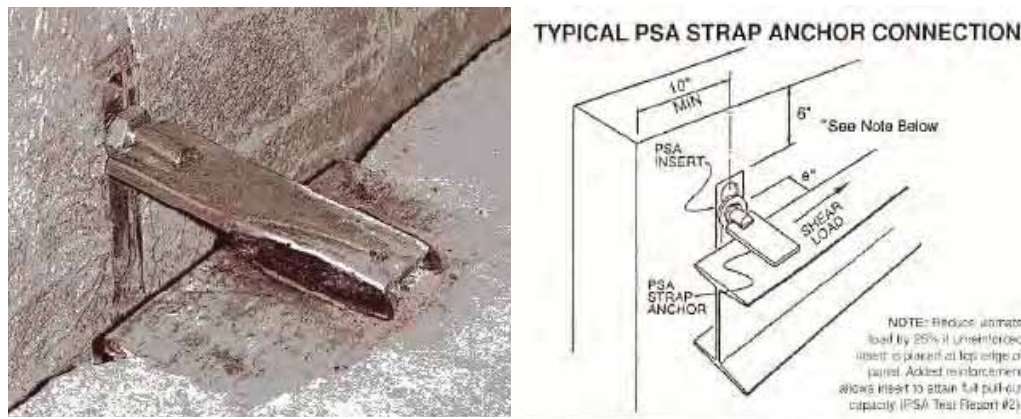

Figure 22. JVI PSA Insert

The PCI panels both used standard stud group connections. Two sizes were used as illustrated in Figure 23. Both were placed at midspan of the panel. The variation between specimens is due to the differences in PC producers. Both connections represent a standard embed used by a PCI certified producer. The stud group used on the TCA panels TCA3-E and F consists of a Meadow Burke Rapid-Lok connection. The connection is rated for a 15-kip vertical and 9-kip horizontal service weight load.

The welding details used for the stud group connectors of PCD1, PCD2, and TS3-E and F are illustrated in Figure 24. To provide a baseline comparison panels TS3-C and D were examined without a discrete connector. For these panels the interior wythe bears directly on a roller support.

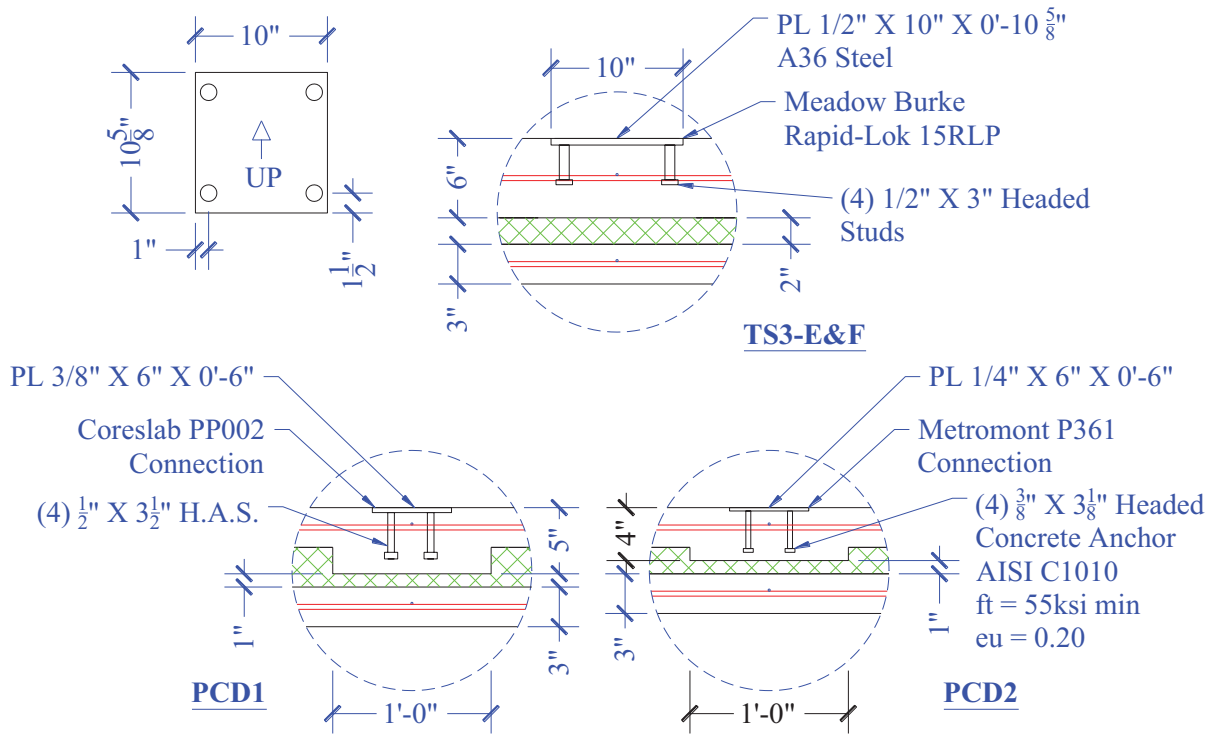

Figure 23. Connection Details for PCI Panels PCD1 and PCD2

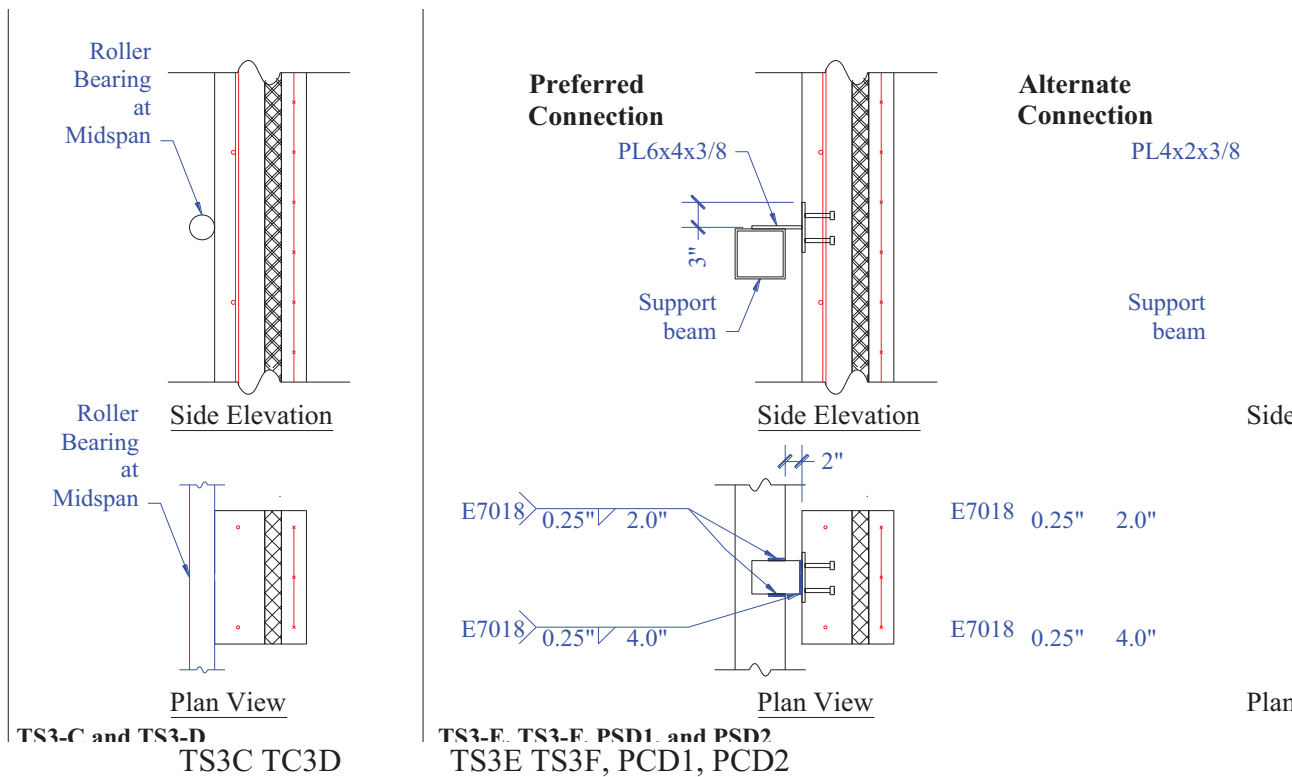

Figure 24. Connection Details

4.3. Single-span Panels with End Connections

Four single-span specimens were fabricated and tested to assess the failure modes of standard panel base connections. The panels were fabricated using the same connection at the top and bottom to ensure that the response was symmetric. These specimens are identified as PCS10 and PCS11. The specimen details are illustrated in Figure 25 and Figure 26. The details of the two connections are included in Figure 28 and Figure 29.

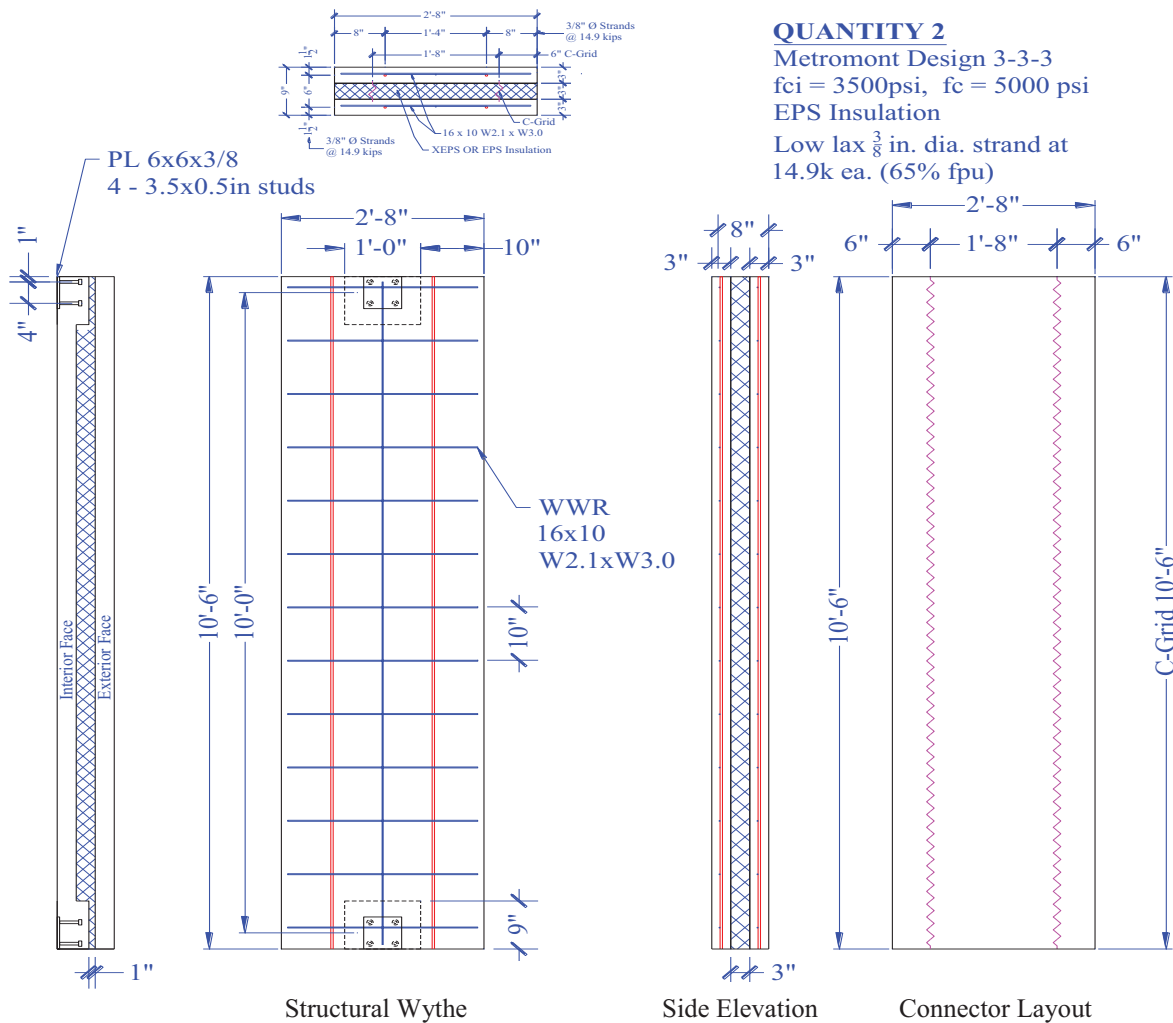

Figure 25. Specimen PCS10—Top Connection

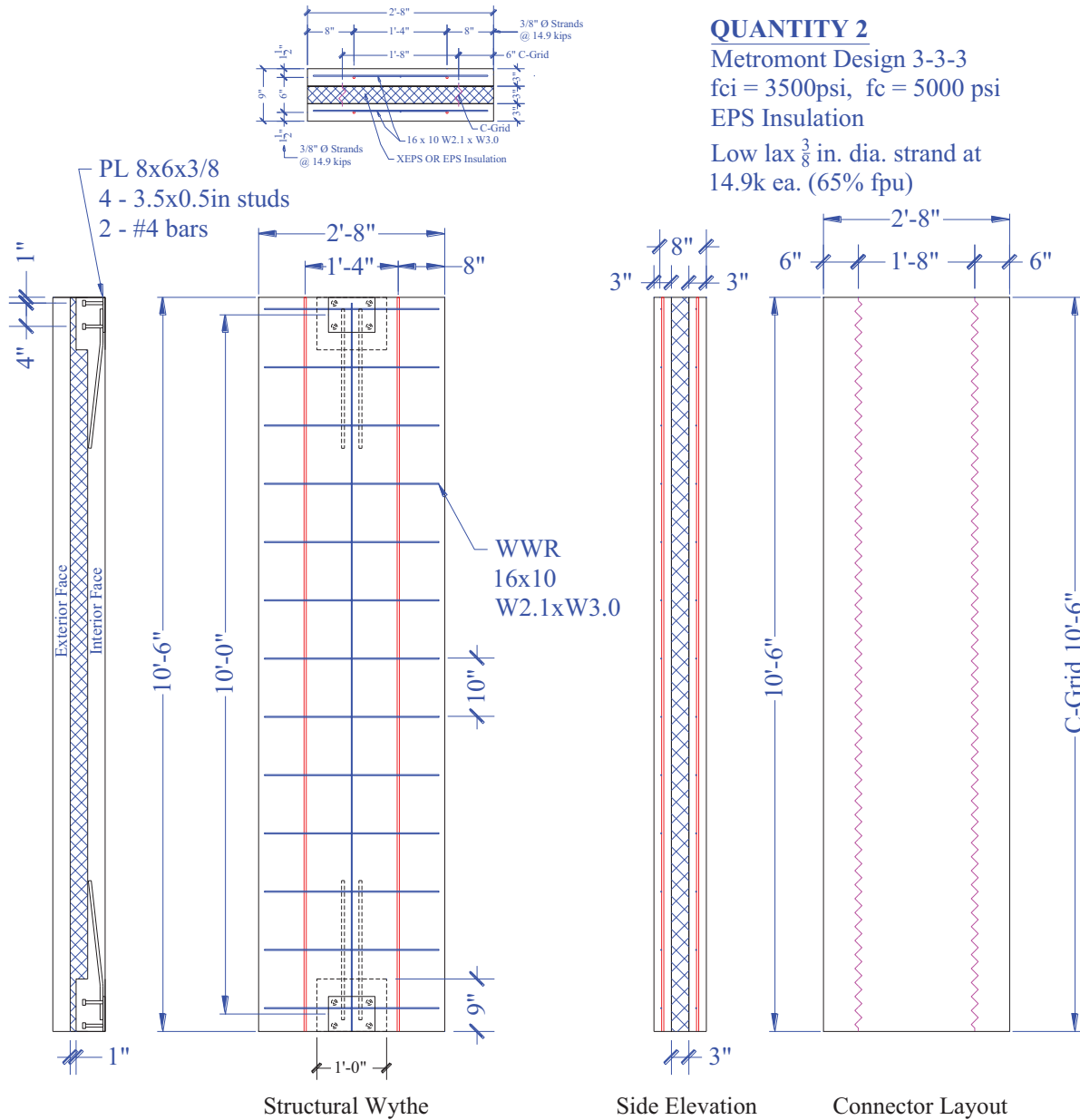

Figure 26. Specimen PCS11—Base Connection

For each set of connection panels one panel was tested with the connection in compression and the other in tension. This allowed for an assessment of the performance under both positive phase response and rebound response as shown in Figure 27. The connection details and the welding requirements for the connectors are presented in Figure 28 and Figure 29. The connectors are made out of ASTM A36 plate material and ASTM A706 reinforcement. The embeds were connected to the reaction frame using structural angles. The detail used in both PCS10 and 11 is illustrated in Figure 30.

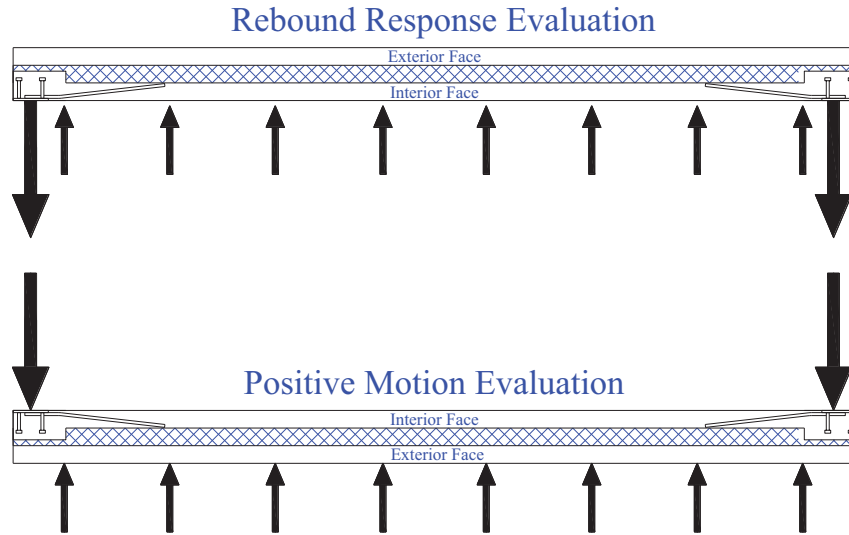

Figure 27. Connection Loading Plan

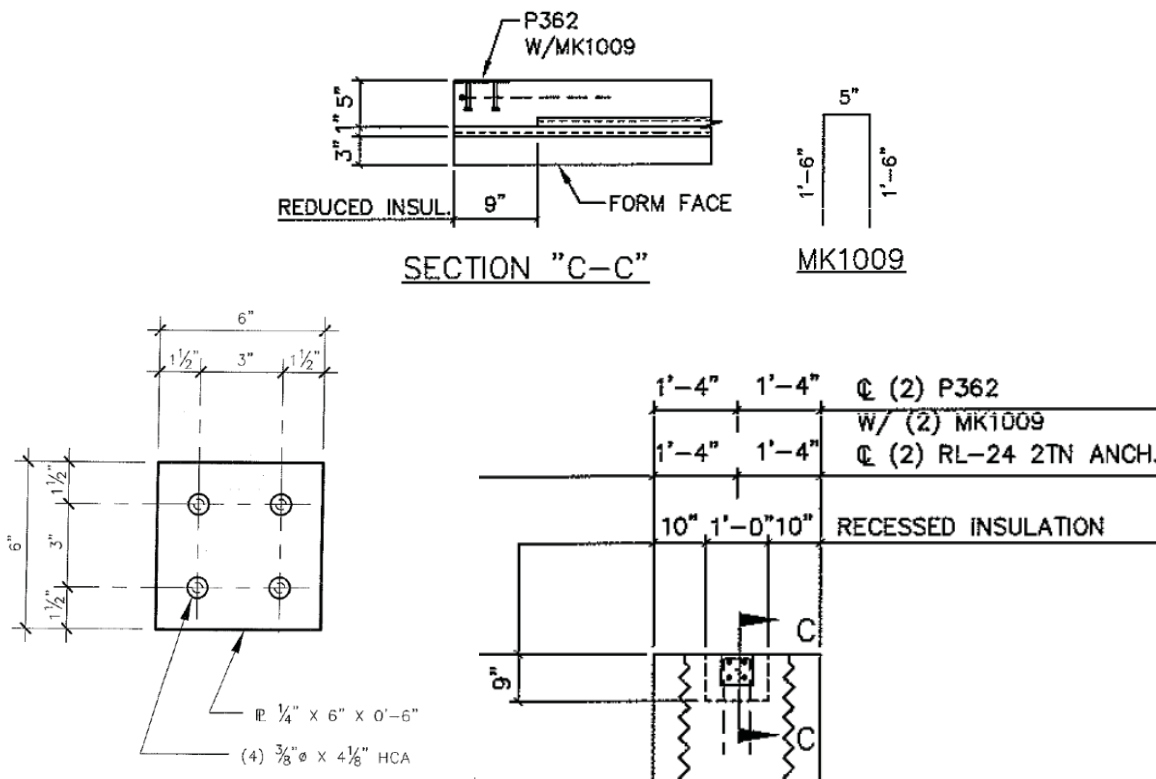

Figure 28. PCS10 Connection Details

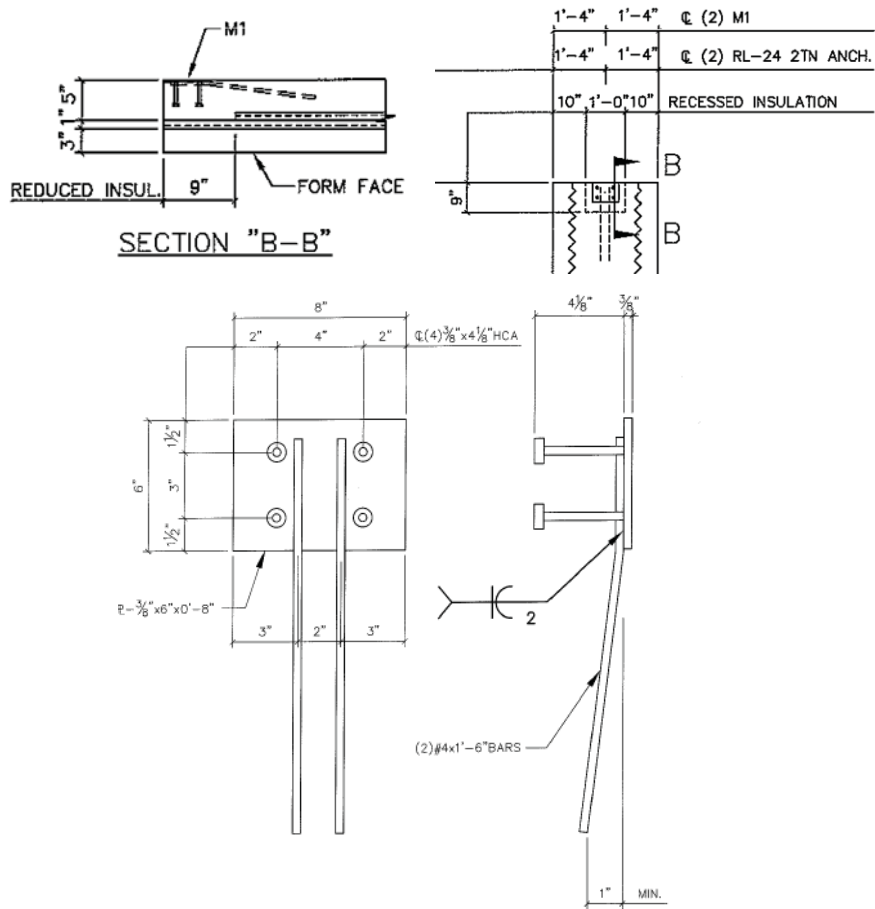

Figure 29. PCS11 Connection Details

- Notes:**
1. All welds shall be performed with E70XX electrodes.
 2. The angles shall be fabricated from ASTM A36 steel.
 3. Collect Mill Certifications for Angles Used.
 4. Ensure throat thickness on welds as they will be the likely failure zone.

**Estimated Capacity
Bending of Angle
6.43kips**

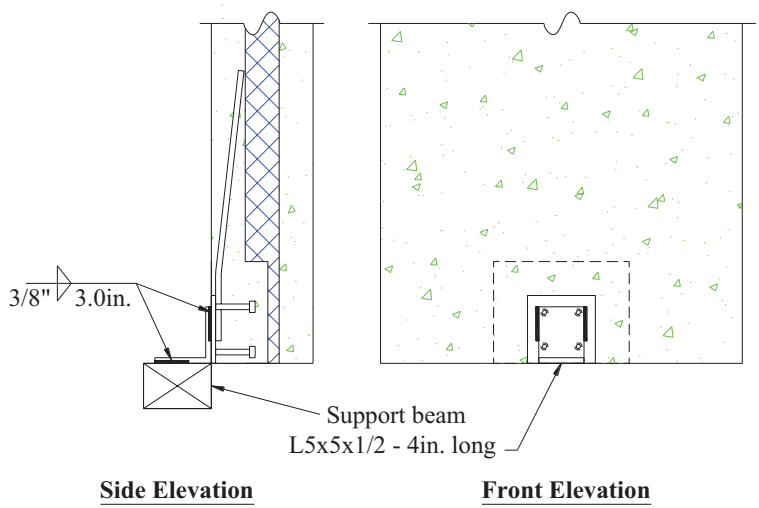

Figure 30. Embed to Support Connection Detail (PCS10 and 11)

4.4. As-built Properties

The location of the reinforcement was measured in each panel post-test. The locations are summarized in Table 6.

Table 6. As-built Reinforcement Locations

Sample	Cut Location	Eastern Half Reinf.		Western Half Reinf.		
		Depth		Depth		
		Int. Wythe	Ext. Wythe	Int. Wythe	Ext. Wythe	
PCS1-A	Near quarter points	1 9/16	1 9/16	1 3/4	1 1/2	
PCS1-B	12 in inside quarter points	1 13/16	1 5/8	1 3/4	1 5/8	
PCS1-C	10 in from midspan	1 3/4	1 5/8	1 5/8	1 1/2	
PCS2-A	10 in inside pick points	1 11/16	1 7/16	1 3/4	1 1/2	
PCS2-B	Near quarter points	1 7/8	1 1/2	2	1 1/2	
PCS2-C	6 in inside pick points	1 7/8	1 9/16	1 15/16	1 1/2	
PCS3-A	15 in from midspan	2 3/8	1 1/2	2 1/2	1 7/8	
PCS3-B	6 in inside pick points	1 3/4	1 5/8	1 3/4	1 5/8	
PCS3-C	12 in pick points	2 1/4	1 3/8	2	1 3/8	
PCS3-D	12 in inside pick points	Rebar:	2	1 3/8	1 7/8	1 1/2
		Strand:	1 5/8	1 9/16	1 5/8	1 9/16
PCS3-E	11 in from midspan	Rebar:	2	1 1/2	1 7/8	1 3/4
		Strand:	2 1/8	1 3/8	2 7/8	1 5/8
PCS3-F	11 in inside pick points	Rebar:	1 7/8	1 5/8	1 7/8	1 5/8
		Strand:	2 1/4	1 1/2	2 1/8	1 1/2
PCS4-A	11 in inside quarter points	1 3/4	1 3/8	1 7/8	1 1/4	
PCS4-B	18 in from midspan	1 13/16	1 1/2	1 5/8	1 1/2	
PCS4-C	10 in from midspan	1 3/4	1 11/16	1 7/8	1 3/4	
PCS5-A	6 in from midspan	1 15/16	1 3/8	1 15/16	1 1/4	
PCS5-B	11 in from midspan	1 3/4	1 1/8	1 3/4	1 1/4	
PCS5-C	12 in from midspan	1 7/8	1 1/2	1 13/16	1 1/2	
PCS 6-A	10 in inside pick points	1 11/16	1 5/8	1 3/4	1 5/8	
PCS6-B	12 in from midspan	1 7/8	1 3/8	1 7/8	1 11/16	
PCS6-C	12 in inside pick points	1 3/4	1 5/8	1 13/16	1 11/16	
PCS7-A	11 in from midspan	1 13/16	1 5/16	1 7/8	1 1/4	
PCS7-B	10 in from midspan	2	1 9/16	2 1/8	1 1/2	
PCS7-C	6 in inside quarter points	1 13/16	1 5/8	1 5/8	1 9/16	
PCS8-A	6 in from midspan	1 13/16	1 5/16	1 13/16	1 3/16	
PCS8-B	12 in inside pick point	1 7/8	1 1/4	1 3/4	1 3/16	
PCS8-C	11 in from midspan	1 7/8	1 1/4	1 13/16	1 5/16	
PCS9-A	15 in from midspan	1 9/16	1 5/8	1 3/4	1 1/2	
PCS9-B	12 in E of midspan, 21 in W of midspan	1 5/8	1 5/8	1 3/4	1 5/8	
PCS9-C	12 in from midspan	1 5/8	1 1/2	1 1/2	1 5/8	
PCS10-A IN	6 in inside pick points	1 11/16	1 1/2	1 5/8	1 1/2	
PCS10-B OUT	8 in outside of pick points	1 15/16	1 3/8	1 7/8	1 3/8	
PCS11-A IN	6 in inside pick points	1 11/16	1 1/2	1 5/8	1 1/2	
PCS11-B OUT	6 in inside pick points	1 1/2	1 3/4	1 1/2	1 13/16	

5. EXPERIMENTAL SETUP

All panels were loaded to failure using a loading tree fixture. The fixture applied loads at discrete points along the panel to generate an approximate uniform load. The point loads were applied through balanced pins that allowed rotation of the individual loading arms. The result was an approximate uniform load along the span. The single-span fixture is illustrated in Figure 31 and Figure 32. The end connections on the single span panels consisted of a heavy-wall steel pipe. These connections were idealized as rollers.

The two-span fixture is illustrated in the schematic shown in Figure 33 and Figure 34. Similar supports were used at the ends of the panel. The midspan connection consisted of a welded detail similar to connections used in the building structure.

The foundation and top floor connections were examined by fabricating the panel with the same connection on both ends. Using the same connection on each end precluded the possibility of a non-symmetric failure mode. The connections were examined for both inbound and rebound response. The setup used is illustrated in Figure 35.

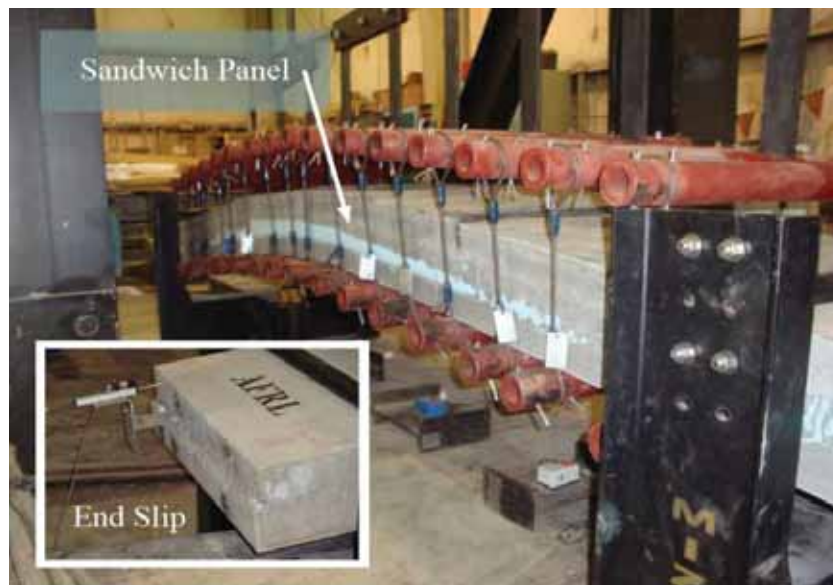

Figure 31. Single-span Loading Tree

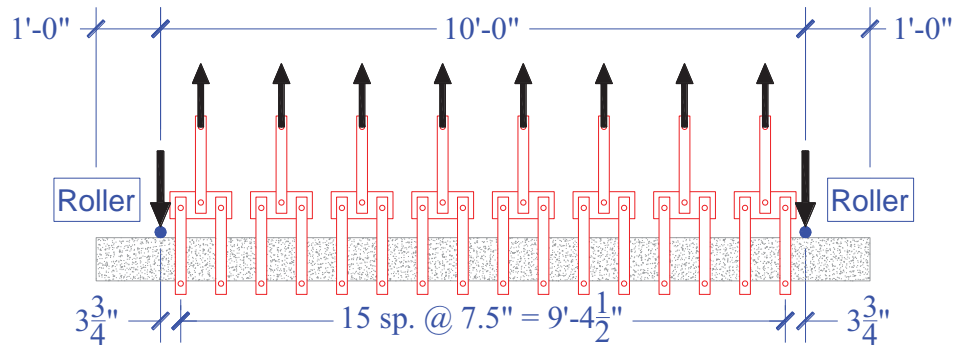

Figure 32. Single-span Loading Tree Schematic

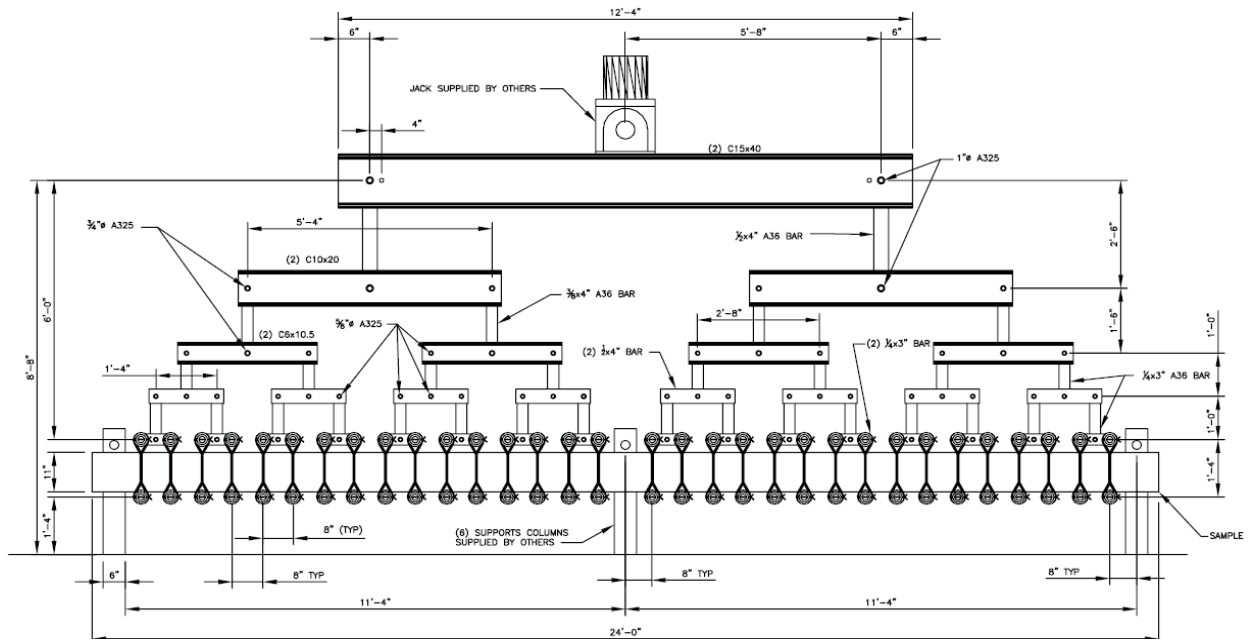

Figure 33. Two-span Loading Tree

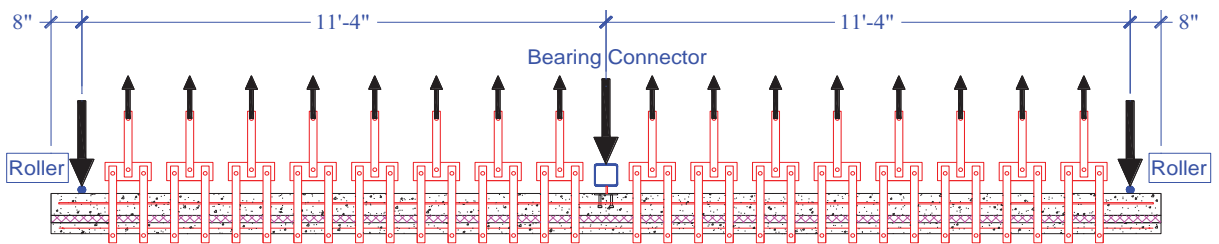

Figure 34. Schematic of Single and Two-span Fixtures

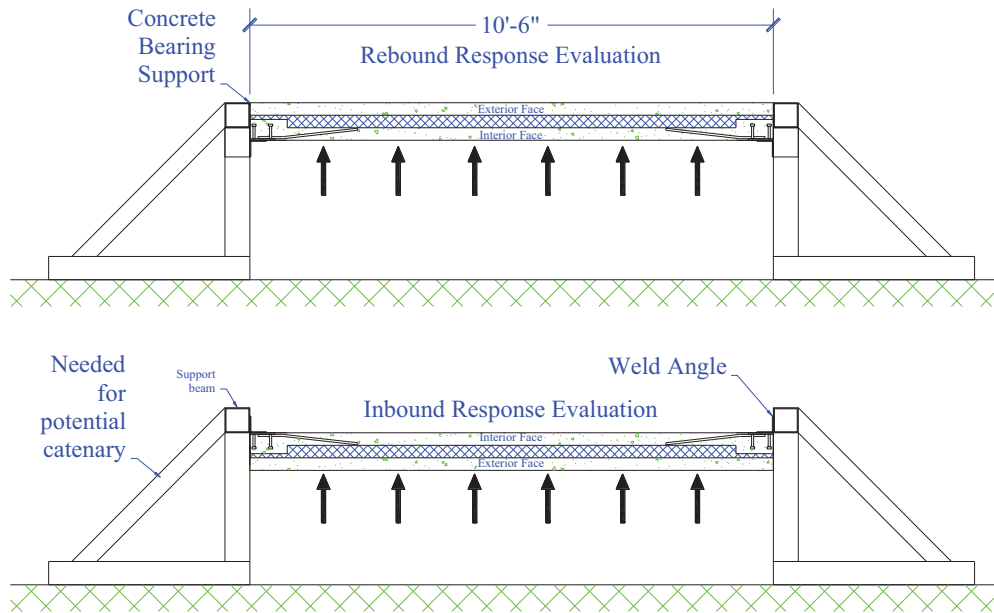

Figure 35. Schematic of End Connection Setup

All specimens were tested in a quasi-static manner at a displacement rate of approximately 0.01 in/sec.

5.1. Instrumentation

Displacements, force and video were recorded for each experiment. The applied load was measured using a load cell in line with the hydraulic actuator. The pressure demand was computed from the measured load by dividing it by the surface area of the specimen. The displacements were measured at mid span and at quarter points of each panel. For the two-span panels the midspan and quarter point displacements were measured on each span. The displacement measurement locations are illustrated in Figure 36.

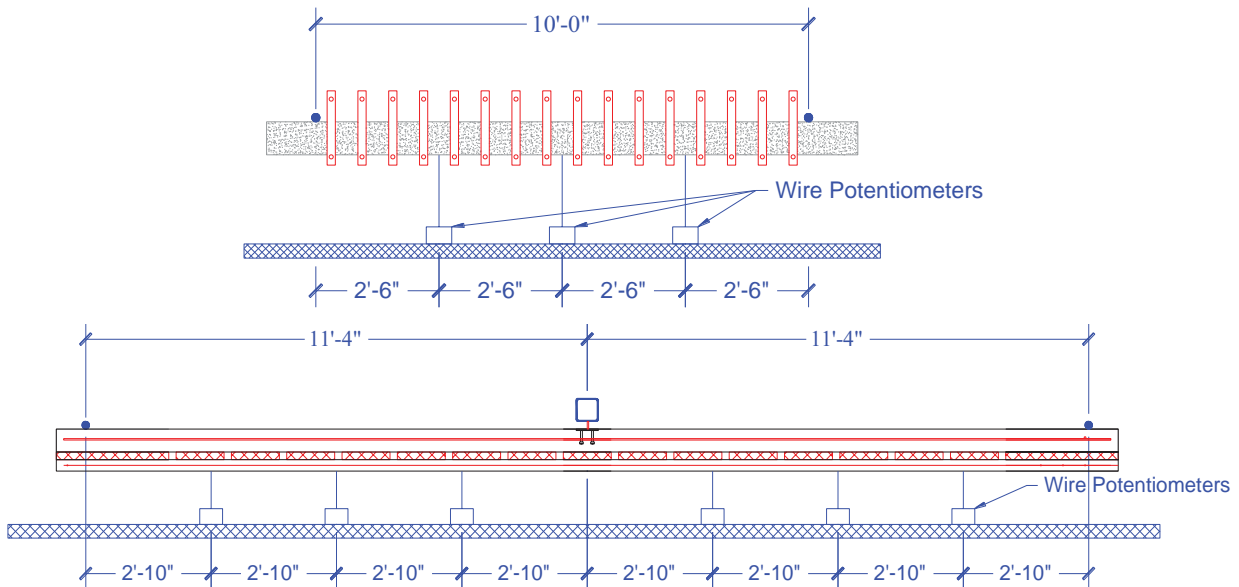

Figure 36. Displacement Instrumentation

To correlate the shear displacement of the shear ties with the failure modes of the panels, the relative deformation of the wythes was measured at each end of the panel. A linear voltage displacement transducer was connected to the exterior wythe, and the relative end slip of the interior wythe was measured as illustrated in Figure 37.

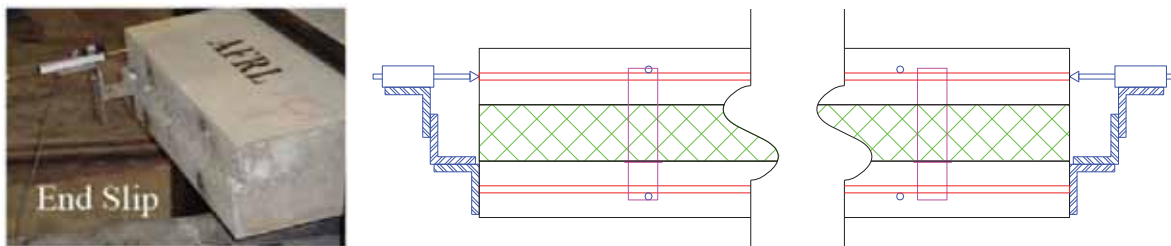

Figure 37. End Shear Instrumentation

5.2. Material Properties

To correlate the material strengths with that of the wall systems, the reinforcement and concrete materials were evaluated. Tensile testing of steel reinforcement samples delivered with the specimens was conducted when material was available. When material was not available, the mill certification data of the steel were noted. The elastic modulus, yield stress, ultimate stress, fracture strain, and a full stress–strain curve were determined for each test. Concrete properties were evaluated in accordance with ASTM C39. In addition, flexural strength tensile tests of the concrete were conducted in accordance with ASTM C293.

5.3. Reinforcement Materials

The specimens were reinforced with a combination of WWR, deformed reinforcing steel, and seven-wire prestressing strand. The reinforcement used in the study conformed to the following specifications.

- *Welded Wire Reinforcement:* ASTM A82
- *Deformed Reinforcement:* ASTM A615 Grade 60 or ASTM A706
- *Prestressing Reinforcement:* Seven Wire 3/8-in diameter low-relaxation strand meeting the requirements of ASTM A416.
-

The allowable tensile properties of the reinforcement are provided in Table 7. The tensile properties of the material used in the specimens are summarized in Table 8.

Table 7. Material Limits

Material	Yield Stress [ksi]	Tensile Strength [ksi]	Ultimate Strain
ASTM A82	65 (min)	75 (min) 1.25 fy (min)	No Requirement
ASTM A615	60 (min)	90 (min)	0.09 (min)
ASTM A706	60 (min) 78 (max)	80 (min)	0.014 (min)
ASTM A416	0.90 fpu (min)	270 (min)	0.035 (min)

Table 8. Mill Certified Reinforcement Properties of Specimens

Specimen	Fabricator	Reinforcing Material	ASTM Method	Yield Stress [ksi]	Tensile Strength [ksi]	Ultimate Strain
PCD1, PCS4, PCS5, PCS7, PCS8,	Coreslab	#3 bar	A615	69.55	111.6	0.15
		#4 bar	A615	67.60	104.8	0.12
		#5 bar	A706	63.00	94.60	0.15
		3/8-in strand	A416	258.08	281.68	0.07
PCD2, PCS1, PCS2, PCS3, PCS6, PCS9	Metromont	#5 bar	NA	NA	NA	NA
		WWR	NA	NA	NA	NA
		3/8-in strand	NA	NA	NA	NA
TS1, TS2, TS3	TCA	6×6 W2.9×W2.9	A185	NA	106.07	NA
		#3 bar	A615	67.80	105.30	0.12
Tyn1, Tyn2	Tyndall	#3 bar	A615	60	NA	NA
		3/8-in strand	A416	NA	270	NA

5.4. Concrete Material Properties

The static specimens were fabricated in accordance with current construction practices. Ready mix concrete with a specified 28-day compressive strength of 4000 psi was used for the tilt-up construction. Plant-batched concrete with a minimum compressive strength of 3500 psi at transfer of prestress and 5000 psi at 28 days was specified. The static wall specimens were tested over a period of seven months. To assess the concrete strength of each wall specimen at the date of the experiment, concrete cylinders were periodically tested to failure in accordance with ASTM C39. Due to the enormity of wall specimens and the duration of the experimental program, cylinders could not be tested along with each panel. Instead the cylinder tests were conducted at various stages throughout the research program. The discrete cylinder test results were used to develop a strength gain curve that was used to estimate the strength of the concrete at each experiment date.

The batching properties for the concrete used for each specimen are summarized in Table 9. The approximate concrete compressive strengths at the day of testing are summarized in

Table 10.

Table 9. Concrete Batching Properties of Specimens

Specimen	Use	Cement	Additional Cementitious Material	w/c Ratio	Unit Weight [pcf]	Slump [in]
PCD1, PCS4, PCS5, PCS7, PCS8,	Both Wythes	Type III	None	0.394	144.28	9.0
PCD2, PCS1, PCS2, PCS3, PCS6, PCS9	Both Wythes	NA	NA	NA	NA	NA
TS1, TS2, TS3	Exterior Wythe	Type I	Fly Ash	0.385	150.0	3.25
	Interior Wythe	Type I	Fly Ash	0.390	148.4	4.50

The concrete modulus of rupture was measured for the TCA specimens in accordance with ASTM C293. Modulus of rupture tests were not conducted on the other specimen concrete. The results for the TCA panels are summarized in Table 11.

Table 10. Concrete Compressive Strength of Specimen [psi]

Specimen	Age at Test [days]	Est. f_c Structural Wythe	Est. f_c Exterior Wythe	Specimen	Age at Test [days]	Est. f_c Structural Wythe	Est. f_c Exterior Wythe
TS1-A	21	4907	5499	PCS9-A	37	8564	8564
TS1-B	22	4947	5539	PCS9-B	41	8650	8650
TS1-C	21	4907	5499	PCS9-C	41	8650	8650
Average		4920	5512	Average		8621	8621
TS2-A	22	4947	5539	PCS10-A	72	9322	9322
TS2-B	21	4907	5499	PCS10-B	85	9604	9604
TS2-C	22	4947	5539	Average		9463	9463
Average		4933	5526	PCS11-A	72	9322	9322
PCS1-A	20	8195	8195	PCS11-B	86	9626	9626
PCS1-B	21	8217	8217	Average		9474	9474
PCS1-C	22	8238	8238	PCS3-D	36	8542	8542
Average		8217	8217	PCS3-E	43	8694	8694
PCS2-A	23	8260	8260	PCS3-F	43	8694	8694
PCS2-B	23	8260	8260	Average		8643	8643
PCS2-C	42	8672	8672	PCD1-A	60	9228	9228
Average		8397	8397	PCD1-B	63	9201	9201
PCS3-A	22	8238	8238	PCD1-C	64	9192	9192
PCS3-B	26	8325	8325	Average		9207	9207
PCS3-C	41	8650	8650	PCD2-A	28	8369	8369
Average		8405	8405	PCD2-B	29	8390	8390
PCS4-A	100	8873	8873	PCD2-C	30	8412	8412
PCS4-B	109	8793	8793	Average		8390	8390
PCS4-C	109	8793	8793	TS3-A	128	5766	6355
Average		8820	8820	TS3-B	132	5772	6361
PCS5-A	101	8864	8864	Average		5769	6358
PCS5-B	112	8766	8766	TS3-C	126	5763	6352
PCS5-C	113	8757	8757	TS3-D	127	5765	6353
Average		8796	8796	Average		5764	6352
PCS6-A	37	8564	8564	TS3-E	136	5778	6366
PCS6-B	45	8737	8737	TS3-F	140	5783	6371
PCS6-C	45	8737	8737	Average		5781	6369
Average		8679	8679	Tyn1 – A	95	8214	8214
PCS7-A	106	8820	8820	Tyn1 – B	99	8275	8275
PCS7-B	106	8820	8820	Tyn1 – C	204	8627	8627
PCS7-C	94	8926	8926	Average		8451	8451
Average		8855	8855	Tyn2 –A	94	8199	8199
PCS8-A	101	8864	8864	Tyn2 –B	101	8306	8306
PCS8-B	108	8802	8802	Tyn2 –C	225	8627	8627
PCS8-C	108	8802	8802	Average		8466	8466
Average		8823	8823				

Table 11. As-built Concrete Tensile Properties

Wythe	Panel Type	Compressive Strength Average [ksi]	Modulus of Rupture	
			Average [ksi]	$x \text{ sqrt}(f_c)$
Structural	TS1, TS2	4650	564.5	8.28
Non-Structural		5110	622.2	8.70

6. EXPERIMENTAL RESULTS FOR SINGLE-SPAN PANELS

A series of 14 PC CSW panels typical of PCI and TCA production were designed. Three specimens of each type of panel were fabricated and tested to failure. The longitudinal reinforcement was varied between reinforcing steel, prestressing steel, and WWR. The tie type and insulation type were varied. The three cross-section types tested were 6-2-3, 3-2-3 and 3-3-3. A summary of each panel type and the results of the tests are presented in this chapter. Included in each section is a summary of the material properties, reinforcement details, load-deformation response, inter-wythe slip (if measured), and ultimate strength. A summary of the fabrication properties and results are included in Table 12 and Table 13.

Table 12. Single-span Fabrication Summary

ID	Configuration	Insulation	Reinforcement	Ties	Designer	Fabricator	Fabricated	Age at Test [days]
TS1-A	6-2-3	XPS	R.C.	THERMOMASS® - NC	TCA	LJB Inc.	9/23/2008	21
TS1-B	6-2-3	XPS	R.C.	THERMOMASS® - NC	TCA	LJB Inc.	9/23/2008	22
TS1-C	6-2-3	XPS	R.C.	THERMOMASS® - NC	TCA	LJB Inc.	9/23/2008	21
TS2-A	3-2-3	XPS	R. C.	THERMOMASS® - Comp	TCA	LJB Inc.	9/23/2008	22
TS2-B	3-2-3	XPS	R. C.	THERMOMASS® - Comp	TCA	LJB Inc.	9/23/2008	21
TS2-C	3-2-3	XPS	R. C.	THERMOMASS® - Comp	TCA	LJB Inc.	9/23/2008	22
PCS1-A	3-2-3	EPS	PS/WWR	Steel C-clips	Metromont	Metromont	2/10/2009	20
PCS1-B	3-2-3	EPS	PS/WWR	Steel C-clips	Metromont	Metromont	2/10/2009	21
PCS1-C	3-2-3	EPS	PS/WWR	Steel C-clips	Metromont	Metromont	2/10/2009	22
PCS2-A	3-2-3	EPS	PS/WWR	C-Grid©	Metromont	Metromont	2/10/2009	23
PCS2-B	3-2-3	EPS	PS/WWR	C-Grid©	Metromont	Metromont	2/10/2009	23
PCS2-C	3-2-3	EPS	PS/WWR	C-Grid©	Metromont	Metromont	2/10/2009	42
PCS3-A	3-2-3	EPS	Rebar/WWR	C-Grid©	Metromont	Metromont	2/11/2009	22
PCS3-B	3-2-3	EPS	Rebar/WWR	C-Grid©	Metromont	Metromont	2/11/2009	26
PCS3-C	3-2-3	EPS	Rebar/WWR	C-Grid©	Metromont	Metromont	2/11/2009	41
PCS3-D	3-2-3	EPS	PS&Rebar/WWR	C-Grid©	Metromont	Metromont	2/10/2009	36
PCS3-E	3-2-3	EPS	PS&Rebar/WWR	C-Grid©	Metromont	Metromont	2/10/2009	43
PCS3-F	3-2-3	EPS	PS&Rebar/WWR	C-Grid©	Metromont	Metromont	2/10/2009	43
PCS4-A	3-3-3	XPS	PS/Rebar	Galvanized Steel C-clips	Coreslab	Coreslab	12/15/2008	100
PCS4-B	3-3-3	XPS	PS/Rebar	Steel C-clips	Coreslab	Coreslab	12/15/2008	109
PCS4-C	3-3-3	XPS	PS/Rebar	Steel C-clips	Coreslab	Coreslab	12/15/2008	109
PCS5-A	3-3-3	XPS	PS/Rebar	THERMOMASS® - Comp	Coreslab	Coreslab	12/15/2008	101
PCS5-B	3-3-3	XPS	PS/Rebar	THERMOMASS® - Comp	Coreslab	Fabricator	12/15/2008	112
PCS5-C	3-3-3	XPS	PS/Rebar	THERMOMASS® - Comp	Coreslab	Coreslab	12/15/2008	113
PCS6-A	3-3-3	XPS	PS/WWR	C-Grid©	Metromont	Metromont	2/10/2009	37
PCS6-B	3-3-3	XPS	PS/WWR	C-Grid©	Metromont	Metromont	2/10/2009	45
PCS6-C	3-3-3	XPS	PS/WWR	C-Grid©	Metromont	Metromont	2/10/2009	45
PCS7-A	3-3-3	XPS	Rebar	THERMOMASS® - Comp	Coreslab	Coreslab	12/15/2008	106
PCS7-B	3-3-3	XPS	Rebar	THERMOMASS® - Comp	Coreslab	Coreslab	12/15/2008	106
PCS7-C	3-3-3	XPS	Rebar	THERMOMASS® - Comp	Coreslab	Coreslab	12/15/2008	94
PCS8-A	3-3-3	PIMA	PS/Rebar	THERMOMASS® - Comp	Coreslab	Coreslab	12/15/2008	101
PCS8-B	3-3-3	PIMA	PS/Rebar	THERMOMASS® - Comp	Coreslab	Coreslab	12/15/2008	108
PCS8-C	3-3-3	PIMA	PS/Rebar	THERMOMASS® - Comp	Coreslab	Coreslab	12/15/2008	108
PCS9-A	3-3-3	PIMA	PS/WWR	C-Grid©	Metromont	Metromont	2/10/2009	37
PCS9-B	3-3-3	PIMA	PS/WWR	C-Grid©	Metromont	Metromont	2/10/2009	41
PCS9-C	3-3-3	PIMA	PS/WWR	C-Grid©	Metromont	Metromont	2/10/2009	41
Tyn1-A	3-4-3	XPS	PS/Rebar	MB Truss Girder	Tyndall	Tyndall	8/3/09	95
Tyn1-B	3-4-3	XPS	PS/Rebar	MB Truss Girder	Tyndall	Tyndall	8/3/09	99
Tyn1-C	3-4-3	XPS	PS/Rebar	MB Truss Girder	Tyndall	Tyndall	8/3/09	204
Tyn2-A	3-4-3	XPS	PS/Rebar	MB Truss Girder	Tyndall	Tyndall	8/3/09	94
Tyn2-B	3-4-3	XPS	PS/Rebar	MB Truss Girder	Tyndall	Tyndall	8/3/09	101
Tyn2-C	3-4-3	XPS	PS/Rebar	MB Truss Girder	Tyndall	Tyndall	8/3/09	225

Table 13. Single-span Results Summary

Specimen	Est. Conc./ f_c Struct.	Est. Conc./ f_c Ext.	Max Load [lbs]	Max Pressure [psi]	Corresponding Displacement [in.]	East Slip [in.]	West Slip [in.]	Rotation [deg]	Measured Moment Capacity [k-in]	d_{top}	d_{bot}	Estimated Composite Capacity [k-in]	Estimated Non-Composite Capacity [k-in]	% Composite	Max Reaction [lbs]
TS1-A	4907	5499	6508	3.389	5.319	NA	NA	5.086	97.614	1.604	8.125	149.704	40.807	52%	3,254
TS1-B	4947	5539	4918	2.561	6.212	NA	NA	5.943	73.768	1.958	7.688	143.297	35.280	36%	2,459
TS1-C	4907	5499	6450	3.359	3.613	NA	NA	3.452	96.749	1.875	7.813	145.239	36.873	55%	3,225
Average	4920	5512	5958	3.10	5.05	NA	NA	4.83	89.4	1.813	7.875	146.080	37.653	48%	2979
TS2-A	4947	5539	8020	4.177	4.925	NA	NA	4.708	120.30	1.625	6.313	121.529	20.149	99%	4,010
TS2-B	4907	5499	8210	4.276	5.047	NA	NA	4.825	123.146	1.719	6.344	123.825	21.109	99%	4,105
TS2-C	4947	5539	8020	4.177	5.918	NA	NA	5.660	120.305	1.500	6.313	119.800	19.230	101%	4,010
Average	4933	5526	8083	4.21	5.30	NA	NA	5.06	121.3	1.615	6.323	121.718	20.163	100%	4042
PCS1-A	8195	8195	17728	4.617	1.712	0.144	0.142	1.635	265.92	1.5313	6.3438	296.1	129.54	82%	8,864
PCS1-B	8217	8217	17693	4.608	2.010	0.134	0.187	1.919	265.39	1.6250	6.2188	296.1	129.54	82%	8,846
PCS1-C	8238	8238	16399	4.271	1.832	0.126	0.195	1.749	245.98	1.5625	6.3125	296.1	129.54	70%	8,199
Average	8217	8217	17273	4.50	1.85	0.13	0.17	1.77	259.1	1.5730	6.292	296.1	129.54	78%	8637
PCS2-A	8260	8260	20448	5.325	1.990	0.291	0.000	1.900	306.73	1.4688	6.2813	296.1	129.54	106%	10,224
PCS2-B	8260	8260	19183	4.996	2.309	0.374	0.003	2.204	287.74	1.5000	6.0625	296.1	129.54	95%	9,591
PCS2-C	8672	8672	19319	5.031	1.345	0.208	0.005	1.284	289.79	1.5313	6.0938	296.1	129.54	96%	9,660
Average	8397	8397	19650	5.12	1.88	0.29	0.00	1.80	294.8	1.500	6.146	296.1	129.54	99%	9825
PCS3-A	8238	8238	21256	5.536	6.000	0.016	0.008	5.711	318.85	1.6875	5.5625	318.88	54.933	100%	10,628
PCS3-B	8325	8325	16328	4.252	0.892	0.041	0.002	0.852	244.92	1.6250	6.2500	318.88	54.933	72%	8,164
PCS3-C	8650	8650	23643	6.157	5.500	0.001	0.090	5.237	354.64	1.3750	5.8750	318.88	54.933	114%	11,821
Average	8405	8405	20409	5.31	4.13	0.02	0.03	3.93	306.1	1.563	5.896	318.88	54.933	95%	10205
PCS3-D	8542	8542	21886	5.699	5.544	0.695	0.368	5.279	328.28	1.4375	6.0625	318.88	54.933	104%	10943
PCS3-E	8694	8694	23645	6.157	5.320	0.652	0.358	5.067	354.67	1.5625	6.3750	318.88	54.933	114%	11822
PCS3-F	8694	8694	20956	5.457	3.896	0.000	0.762	3.716	314.34	1.5000	6.5000	318.88	54.933	98%	10478
Average	8643	8643	22162	5.770	4.920	0.450	0.500	4.690	332.4	1.500	6.313	318.880	54.933	105%	11081
PCS4-A	8873	8873	18410	4.794	6.943	0.673	0.897	6.601	276.14	1.3125	7.1875	347.49	129.54	67%	9,205
PCS4-B	8793	8793	16138	4.203	5.408	0.250	0.974	5.151	242.07	1.5000	7.2813	347.49	129.54	52%	8,069
PCS4-C	8793	8793	19110	4.976	6.355	0.512	0.909	6.046	286.65	1.7188	7.1875	347.49	129.54	72%	9,555
Average	8820	8820	17886	4.66	6.24	0.48	0.93	5.93	268.3	1.510	7.219	347.49	129.54	64%	8943
PCS5-A	8864	8864	17770	4.628	4.765	0.527	0.604	4.541	266.55	1.3125	7.0625	347.49	129.54	63%	8,885
PCS5-B	8766	8766	19910	5.185	5.118	0.500	0.562	4.875	298.65	1.1875	7.2500	347.49	129.54	78%	9,955
PCS5-C	8757	8757	18252	4.753	5.536	0.633	0.637	5.272	273.78	1.5000	7.1563	347.49	129.54	66%	9,126
Average	8796	8796	18644	4.86	5.14	0.55	0.60	4.90	279.7	1.333	7.156	347.490	129.54	69%	9322
PCS6-A	8564	8564	18581	4.839	3.644	0.502	0.504	3.475	278.71	1.6250	7.2813	347.49	129.54	68%	9,290
PCS6-B	8737	8737	18146	4.726	2.945	0.443	0.236	2.810	272.19	1.5313	7.1250	347.49	129.54	65%	9,073
PCS6-C	8737	8737	13233	3.446	2.061	0.021	0.413	1.968	198.50	1.6563	7.2188	347.49	129.54	32%	6,617
Average	8679	8679	16653	4.34	2.88	0.32	0.38	2.75	249.8	1.604	7.208	347.49	129.54	55%	8327
PCS7-A	8820	8820	18661	4.860	7.434	0.847	0.809	7.063	279.91	1.2813	7.1563	368.3	54.93	72%	9,330
PCS7-B	8820	8820	19484	5.074	6.744	0.615	0.905	6.413	292.26	1.5313	6.9375	368.3	54.93	76%	9,742
PCS7-C	8926	8926	15561	4.0524	4.4584	0.2757	0.7599	4.2497	233.42	1.5938	7.2813	368.3	54.93	57%	7,781
Average	8855	8855	17902	4.66	6.21	0.58	0.82	5.91	268.5	1.469	7.125	368.3	54.93	68%	8951
PCS8-A	8864	8864	15051	3.9195	4.3814	0.6930	0.3873	4.1765	225.76	1.2500	7.1875	347.49	129.54	44%	7,525
PCS8-B	8802	8802	14369	3.7420	2.6614	0.5794	0.2102	2.5398	215.54	1.2188	7.1875	347.49	129.54	39%	7,185
PCS8-C	8802	8802	16901	4.4013	5.2511	0.6607	0.5929	5.0017	253.51	1.2813	7.1563	347.49	129.54	57%	8,450
Average	8823	8823	15440	4.02	4.10	0.64	0.40	3.91	231.6	1.250	7.177	347.49	129.54	47%	7720
PCS9-A	8564	8564	21311	5.550	1.809	0.190	0.180	1.727	319.67	1.5625	7.3438	347.49	129.54	87%	10,656
PCS9-B	8650	8650	20804	5.418	1.882	0.235	0.133	1.797	312.06	1.6250	7.3125	347.49	129.54	84%	10,402
PCS9-C	8650	8650	22455	5.848	2.573	0.152	0.356	2.456	336.82	1.5625	7.4375	347.49	129.54	95%	11,227
Average	8621	8621	21524	5.61	2.09	0.19	0.22	1.99	322.9	1.583	7.365	347.49	129.54	89%	10762
Tyn1-A	8214	8214	21867	5.69	0.47	NA	NA	0.446	328.0	NA	NA				
Tyn1-B	8275	8275	20331	5.29	0.58	NA	NA	0.553	305.0	NA	NA				
Tyn1-C	8627	8627	20044	5.22	0.71	NA	NA	0.681	300.7	1.438	8.375				
Average	8451	8451	20747	5.40	0.59	NA	NA	0.56	311.2						
Tyn2-A	8199	8199	21847	5.69	0.84	NA	NA	0.802	327.7	NA	NA				
Tyn2-B	8306	8306	18635	4.85	2.89	NA	NA	2.758	279.5	NA	NA				
Tyn2-C	8627	8627	18987	4.94	4.35	NA	NA	4.157	284.8	1.250	8.266				
Average	8466	8466	19823	5.16	2.69	NA	NA!	2.57	297.3						

6.1. TS1 6-2-3 Specimen Performance

TS1 consists of a non-composite 6-2-3 tilt-up CSW panel fabricated with THERMOMASS® non-composite shear ties. The panel is non-PS with #3 transverse reinforcement in the structural wythe and WWR in the non-structural wythe. The panel cross-section is illustrated in Figure 38.

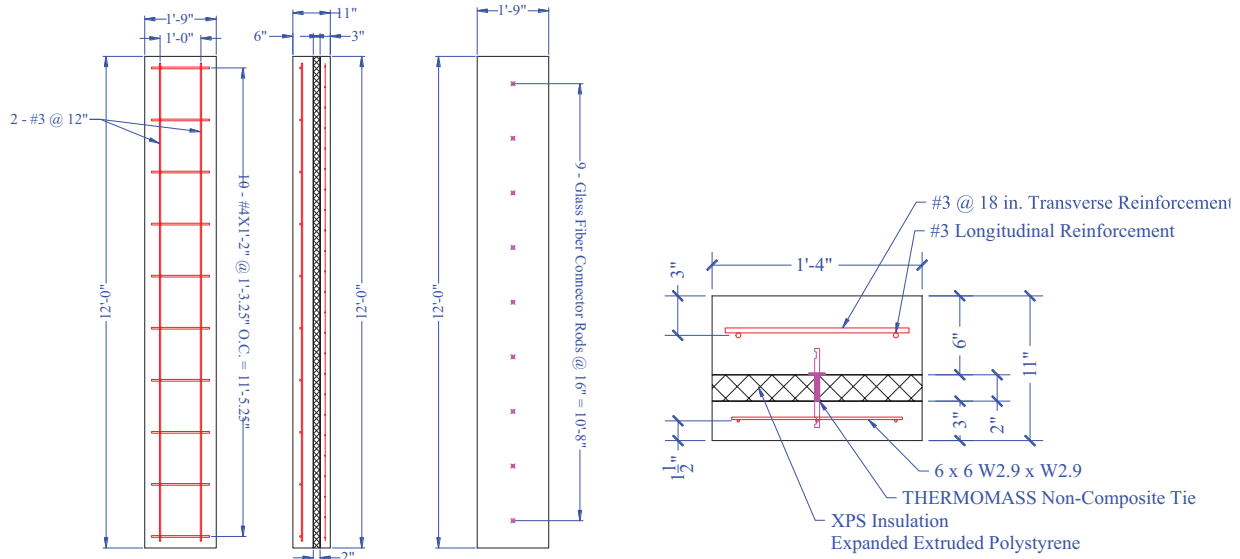

Figure 38. TS1 Reinforcement Details

The material properties for the specimen and the measured response are summarized in Table 14 and Table 15. The midspan pressure displacement and moment–support rotation for the three specimens follow in Figure 39 and Figure 40. The individual response of each panel and the quarter point displacements are included at the end in Displacement [in]

Figure 41-43. Figure 44 shows a picture representation of the three samples post-test.

Table 14. TS1 Material Properties

Property	Value [psi]
f'_c Structural Wythe	4650
f'_c Non-Structural Wythe	5110
Rebar Yield Strength	69710
Rebar Ultimate Strength	107118
WWR Yield Strength	93930
WWR Ultimate Strength	96620

Table 15. TSI Measured Response

Specimen	Type	Max Load [lbs]	Max Pressure [psi]	Corresponding Displacement [in]	Corr. Rotation [deg]	Measured Moment Capacity [k-in]
TS1-A	6-2-3	6508	3.389	5.32	5.07	97.61
TS1-B	6-2-3	4918	2.561	6.21	5.91	73.77
TS1-C	6-2-3	6450	3.359	3.61	3.45	96.75
Average		5958	3.1	5.0	4.8	89.4
COV		15.1%	15.1%	26.2%	26.1%	15.1%

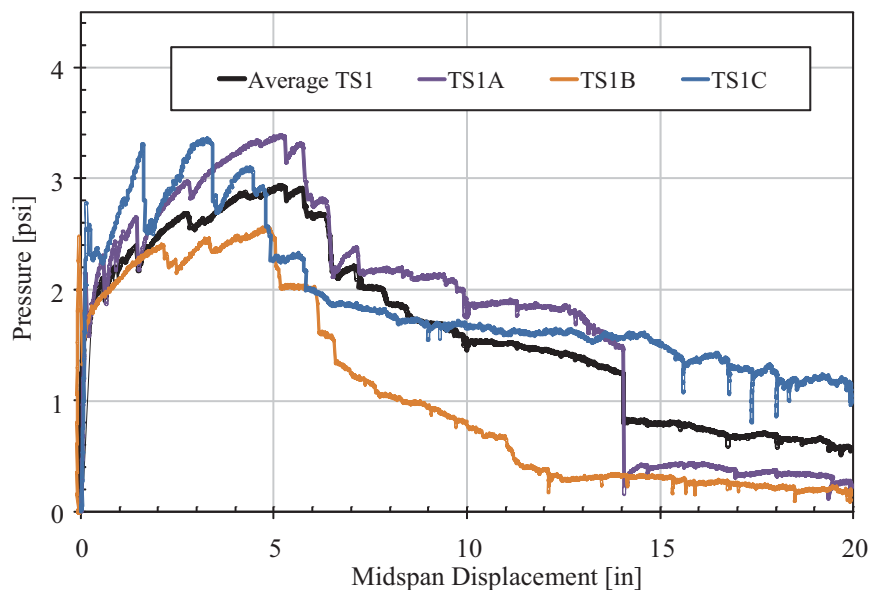

Figure 39. TS1 6-2-3 Pressure—Midspan Displacement

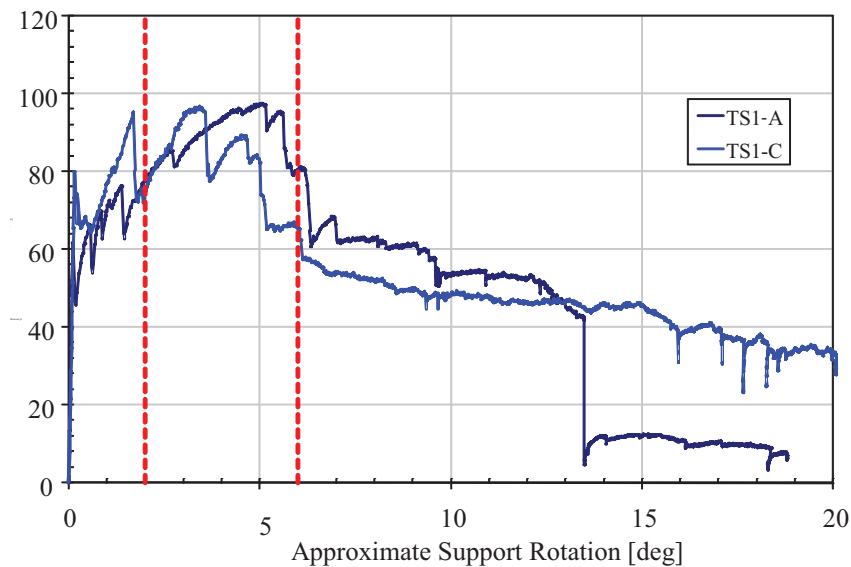

Figure 40. TS1 6-2-3 Moment—Rotation

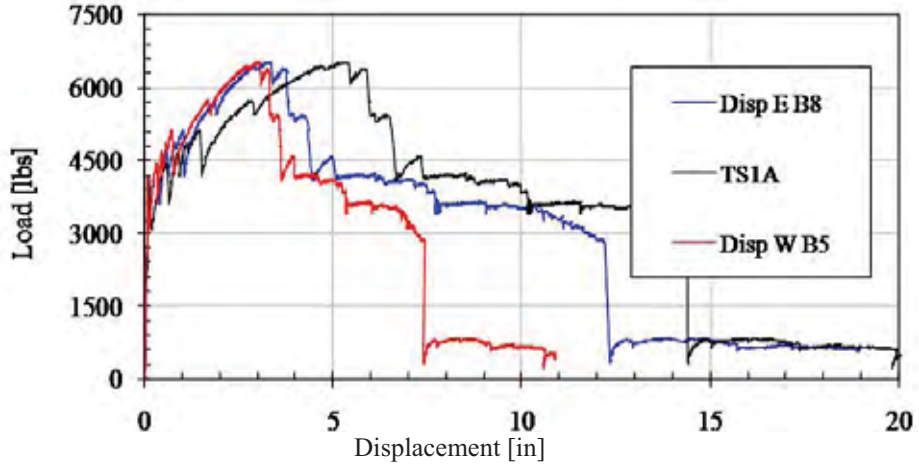

Figure 41. TS1-A Detail Results

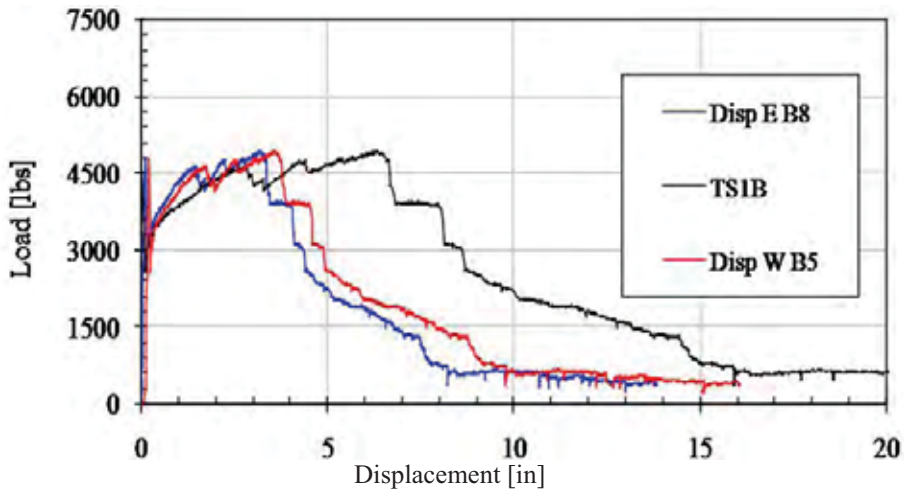

Figure 42. TS1-B Detail Results

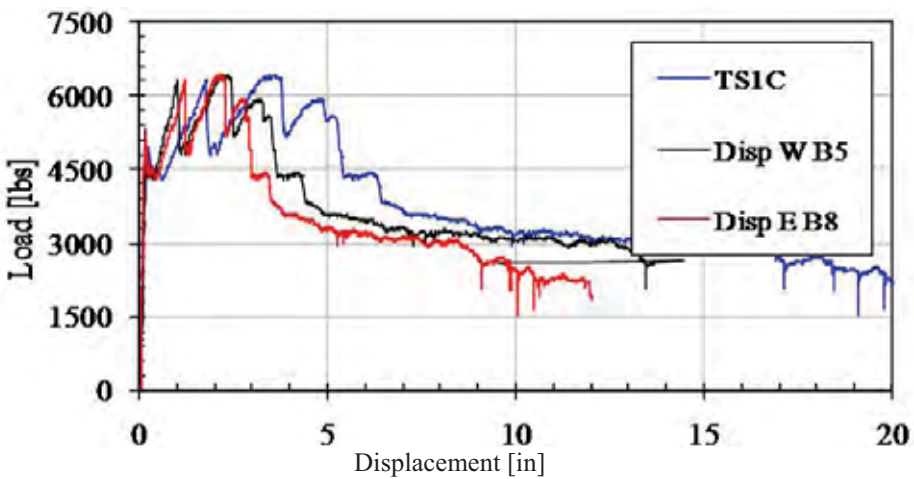

Figure 43. TS1-C Detail Results



Figure 44. TS1 Panel Response (A, B, C)

6.2. TS2 3-2-3 Specimen Performance

TS2 consists of a partially composite 3-2-3 tilt-up CSW panel fabricated with THERMOMASS® composite shear ties. The panel is non-PS with #3 transverse reinforcement in the structural wythe and WWR in both the interior and exterior wythe. The panel cross-section is illustrated in Figure 45.

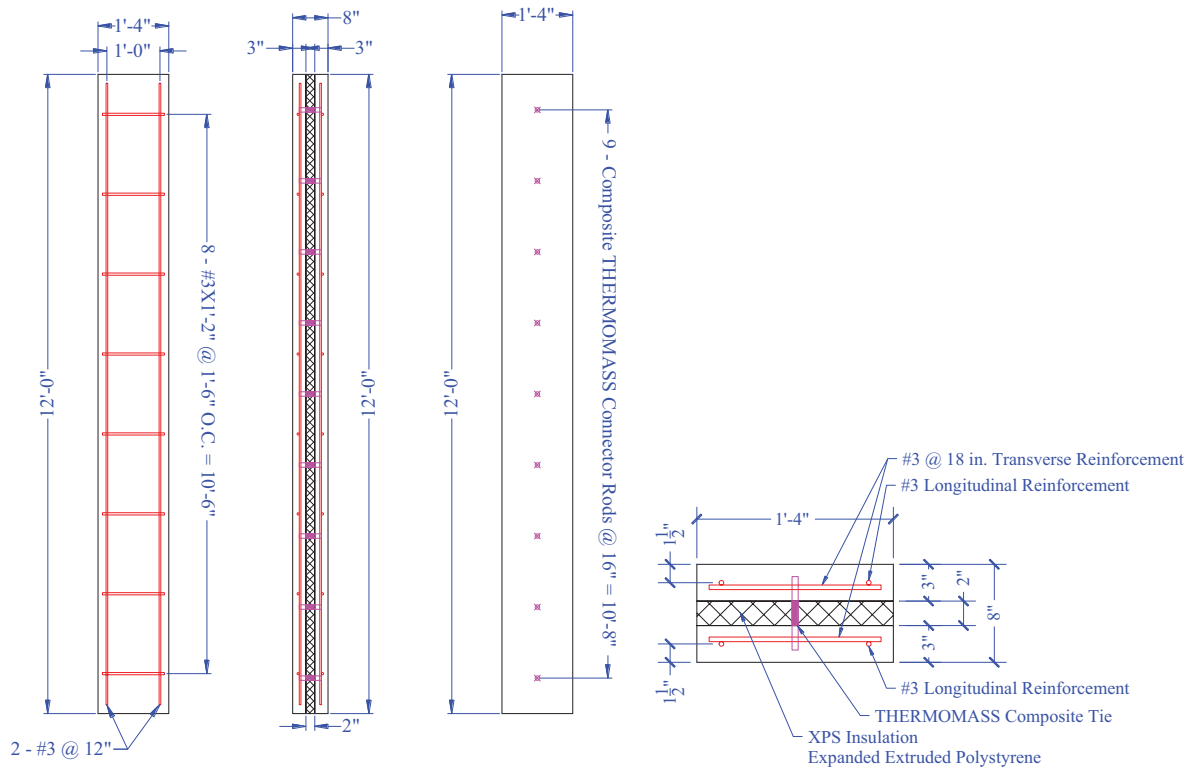

Figure 45. TS2 Reinforcement Details

The material properties for the specimen and the measured response are summarized in Table 16 and Table 17. The midspan pressure displacement and moment–support rotation for the three specimen follow in Figure 46 and Figure 47. The individual response of each panel and the quarter point displacements are included at the end in Figure 48-Figure 50. Figure 51 shows a picture representation of the three samples post-test.

Table 16. TS2 Material Properties

Property	Value [psi]
f_c Structural Wythe	4650
f_c Non-Structural Wythe	5110
Rebar Yield Strength	69710
Rebar Ultimate Strength	107118
WWR Yield Strength	93930
WWR Ultimate Strength	96620

Table 17. TS2 Measured Response

Specimen	Type	Max Load [lbs]	Max Pressure [psi]	Corresponding Displacement [in]	Corr. Rotation [deg]	Measured Moment Capacity [k-in]
TS2-A	3-2-3	8020	4.177	4.92	4.69	120.30
TS2-B	3-2-3	8210	4.276	5.05	4.81	123.15
TS2-C	3-2-3	8020	4.177	5.92	5.63	120.30
	Average	8083	4.2	5.3	5.0	121.3
	COV	1.4%	1.4%	10.2%	10.2%	1.4%

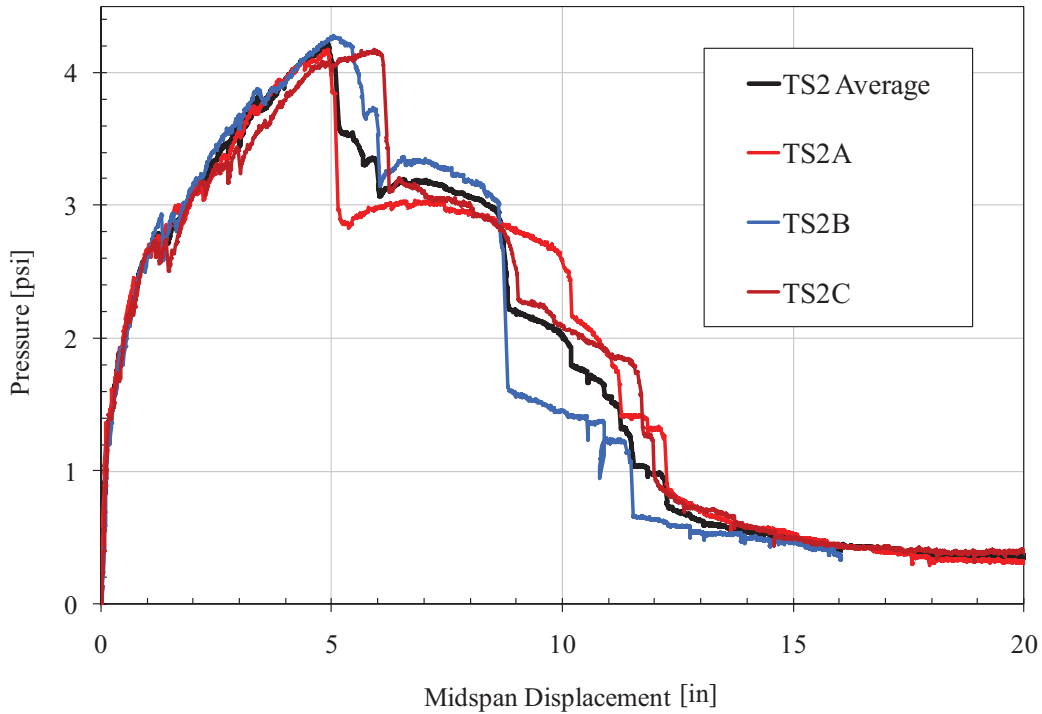

Figure 46. 3-2-3 Pressure—Midspan Displacement

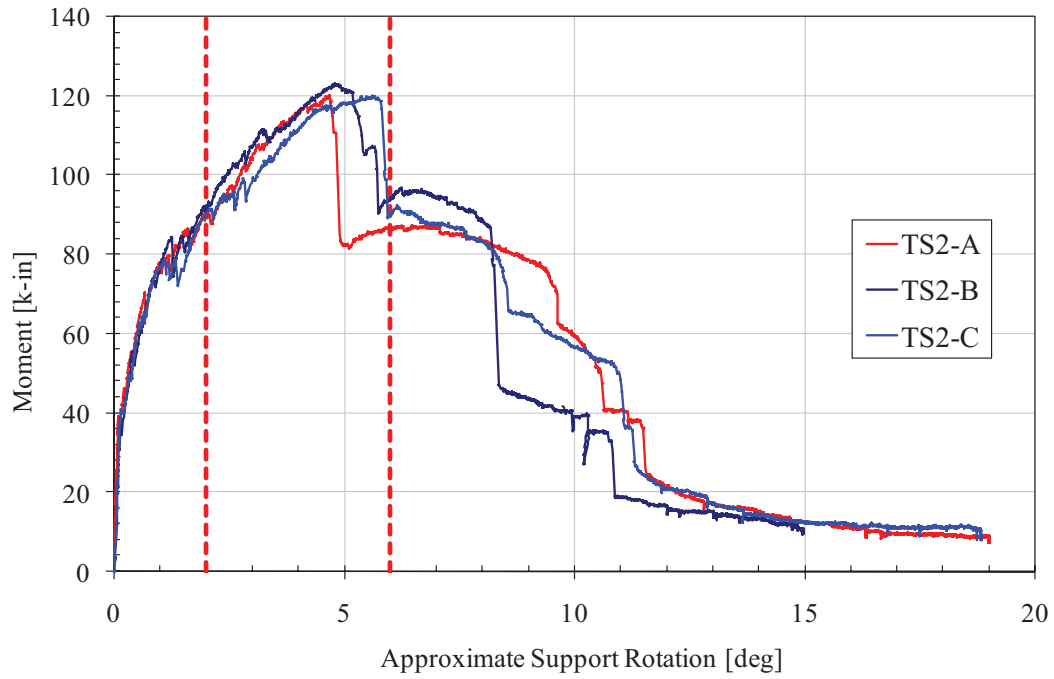

Figure 47. TS2 3-2-3 Moment Rotation at Midspan

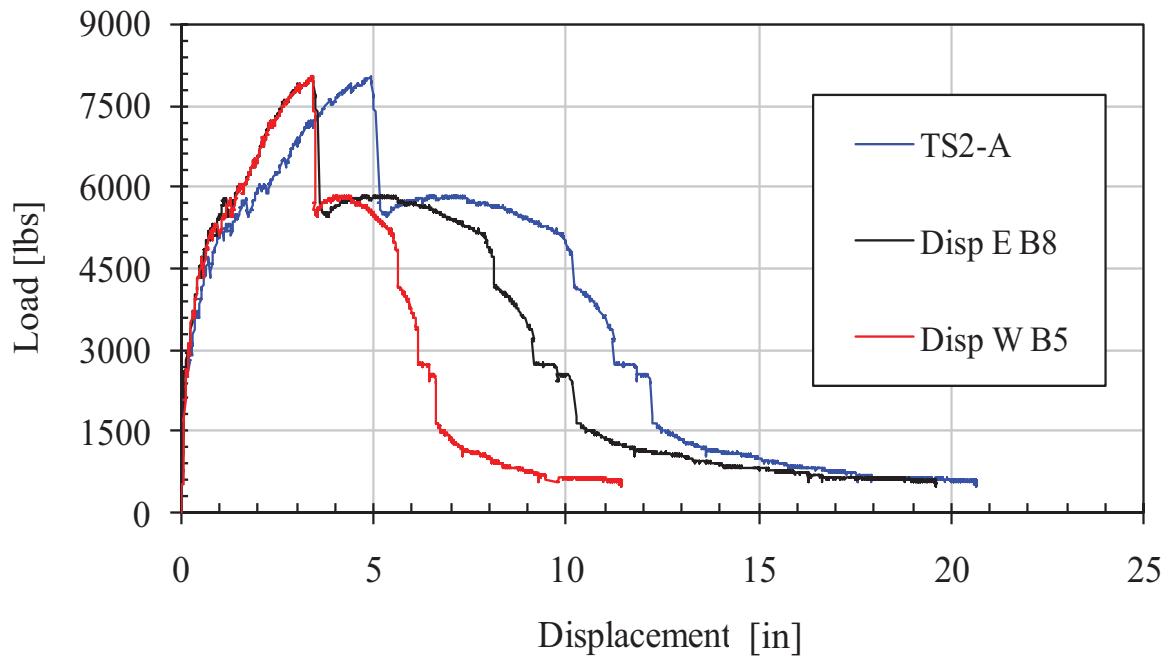

Figure 48. TS2-A Detail Results

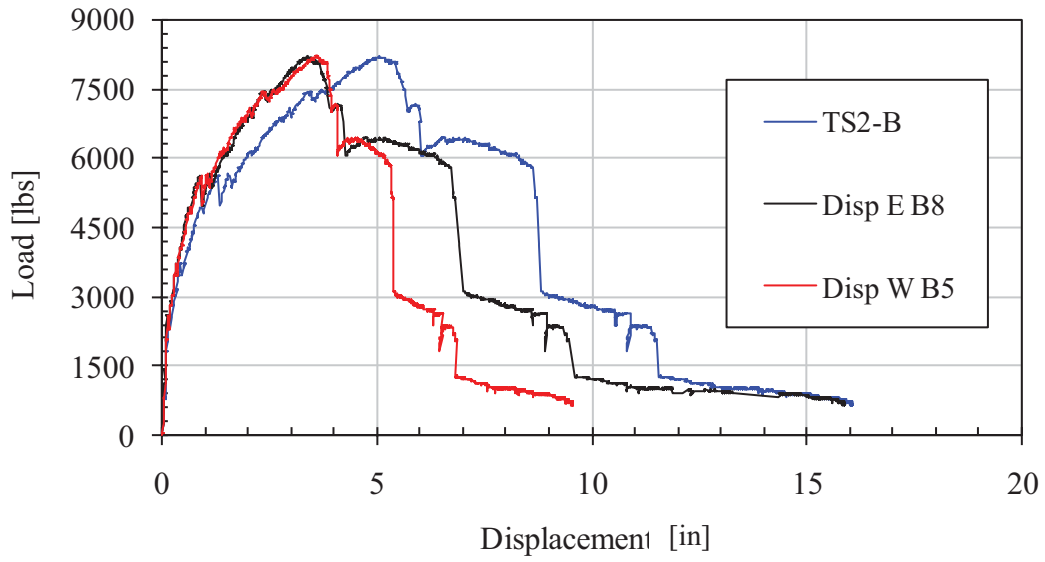

Figure 49. TS2-B Detail Results

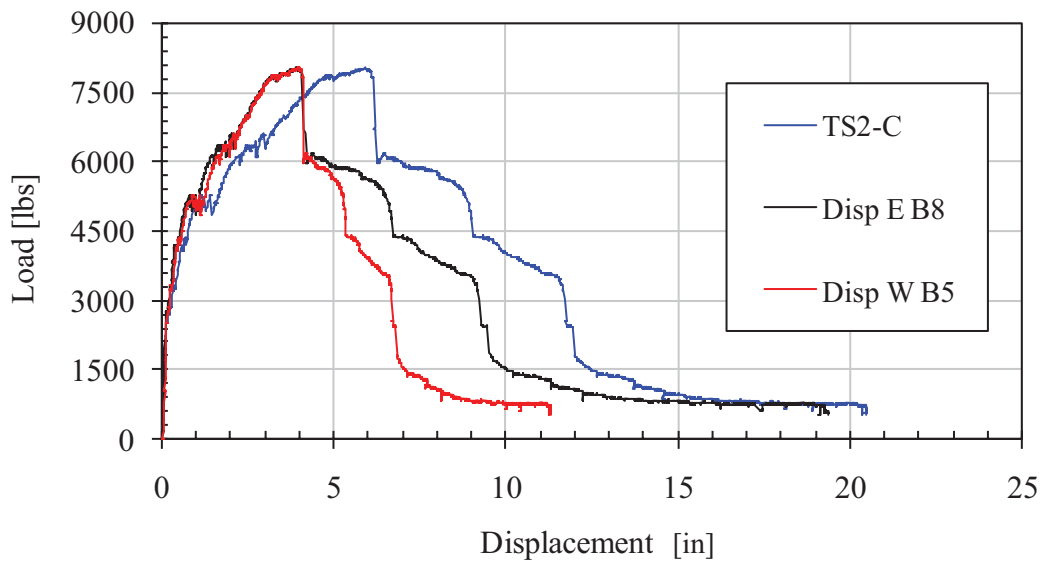

Figure 50. TS2-C Detail Results



Figure 51. TS2 Panel Response (A, B, C)

6.3. PCS1 3-2-3 Specimen Performance

PCS1 consists of a partially composite 3-2-3 PC CSW panel fabricated with EPS insulation and steel C-clip shear ties. The panel is PS with WWR transverse reinforcement in both the interior and exterior wythe. The panel cross-section is illustrated in Figure 52 and Figure 53.

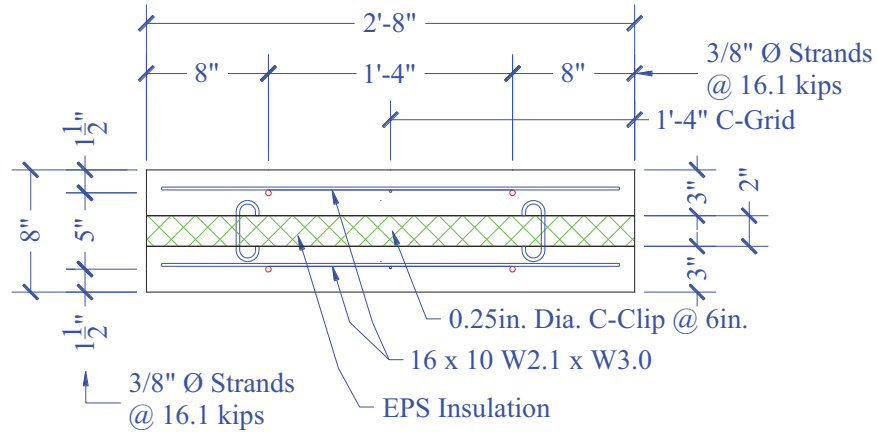

Figure 52. PCS1 Cross-Section Detail

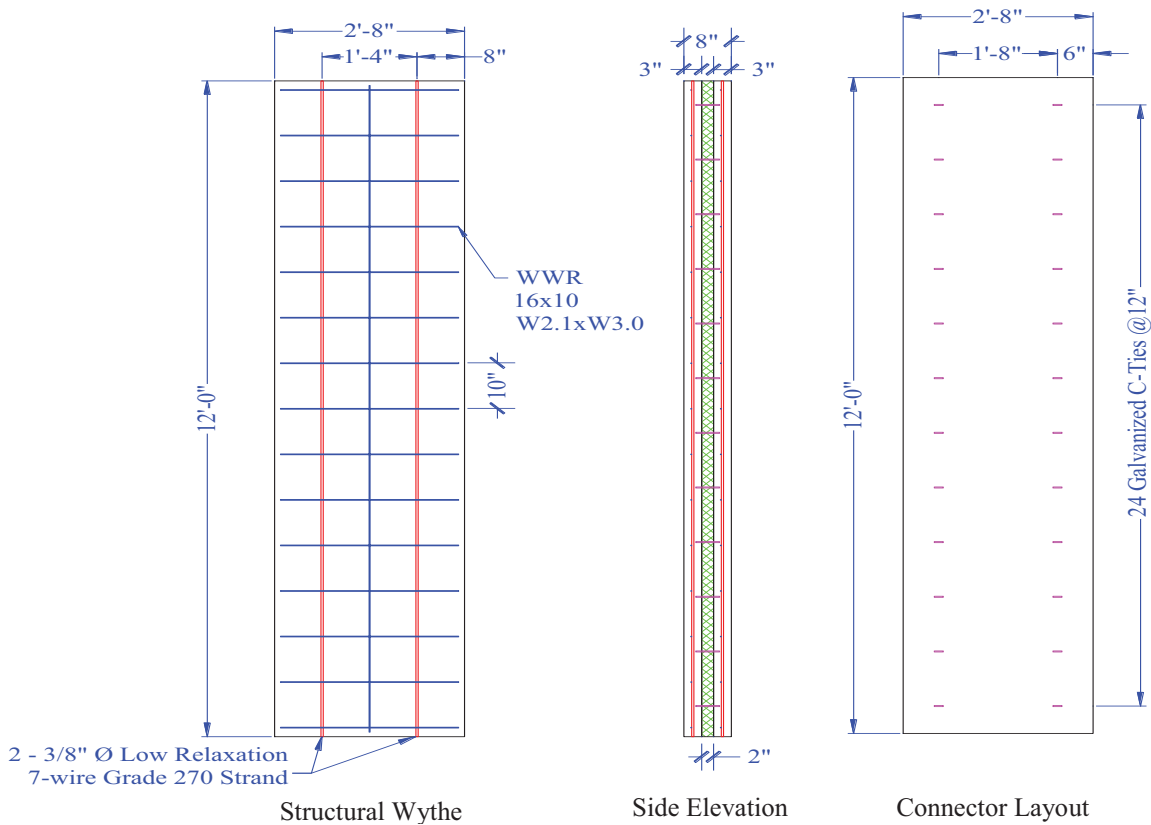

Figure 53. PCS1 Panel Detail

The measured response is summarized in the Table 18. The midspan pressure displacement and moment-support rotation for the three specimen are in Figure 54 and Figure 55. The individual response of each panel and the quarter point displacements are included in Figure 56-58. A picture representation of the samples post-test is shown in Figure 59

Table 18. PCS1 Measured Response

Specimen	Wythe Configuration	Age at Test [days]	Max Load [lbs]	Max Pressure [psi]	Corresponding Displacement [in]	East Slip [in]	West Slip [in]	Measured Moment Capacity [k-in]
PCS1-A	3-2-3	20	17728	4.617	1.712	0.144	0.142	265.92
PCS1-B	3-2-3	21	17693	4.608	2.010	0.134	0.187	265.39
PCS1-C	3-2-3	22	16399	4.271	1.832	0.126	0.195	245.98
Average			17273	4.498	1.851	0.135	0.175	259.10
COV			4.4%	4.4%	8.1%	6.7%	16.1%	4.4%

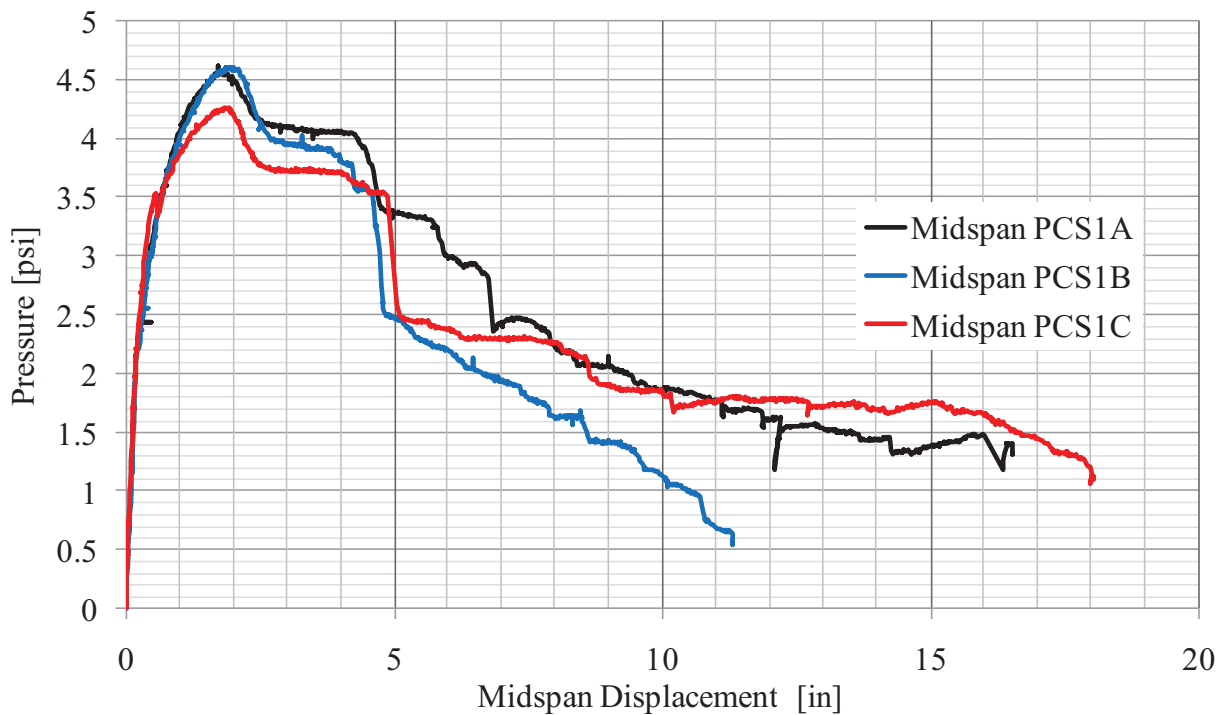

Figure 54. PCS1 Pressure–Displacement Response

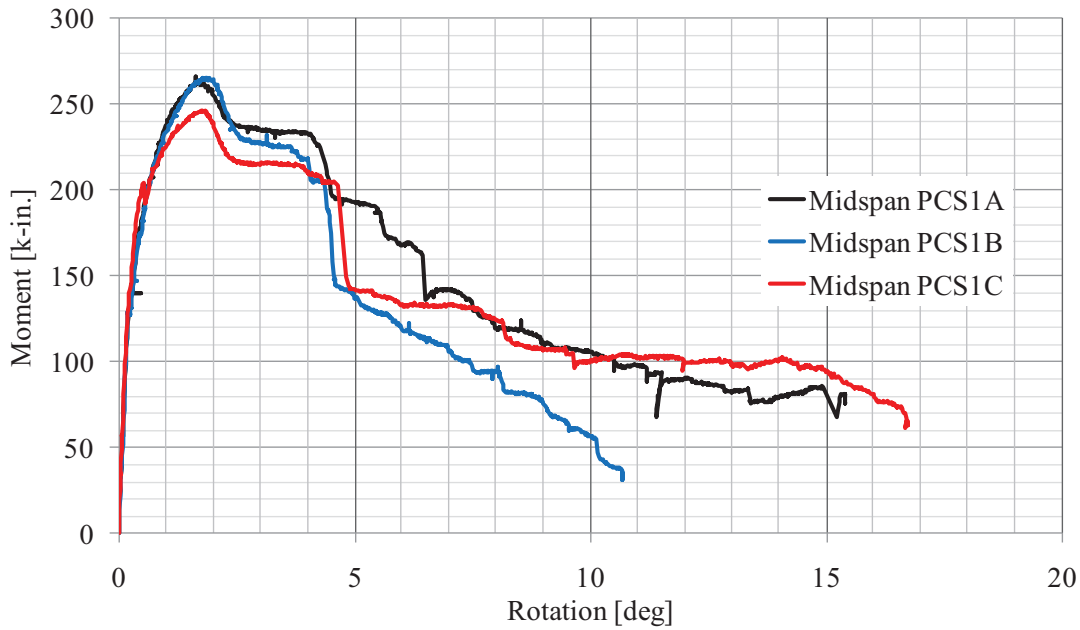

Figure 55. PCS1 Moment-Rotation Response

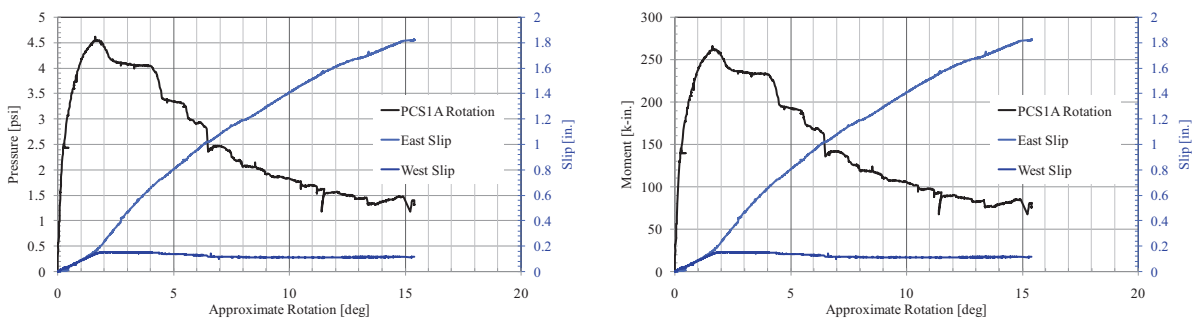
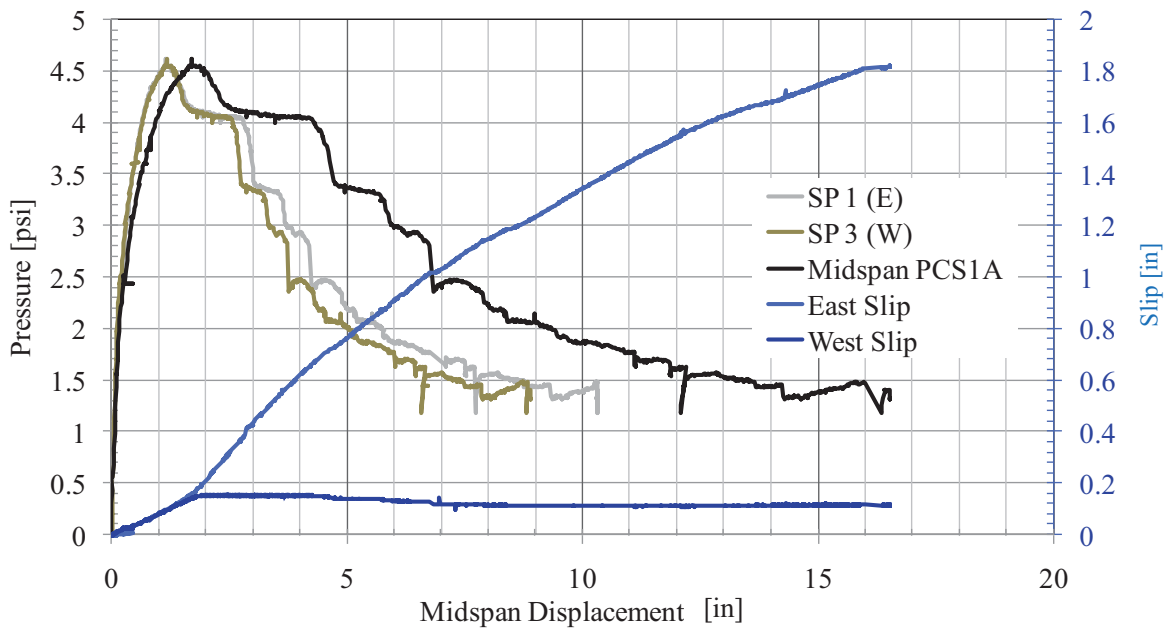

Figure 56. PCS1-A Response

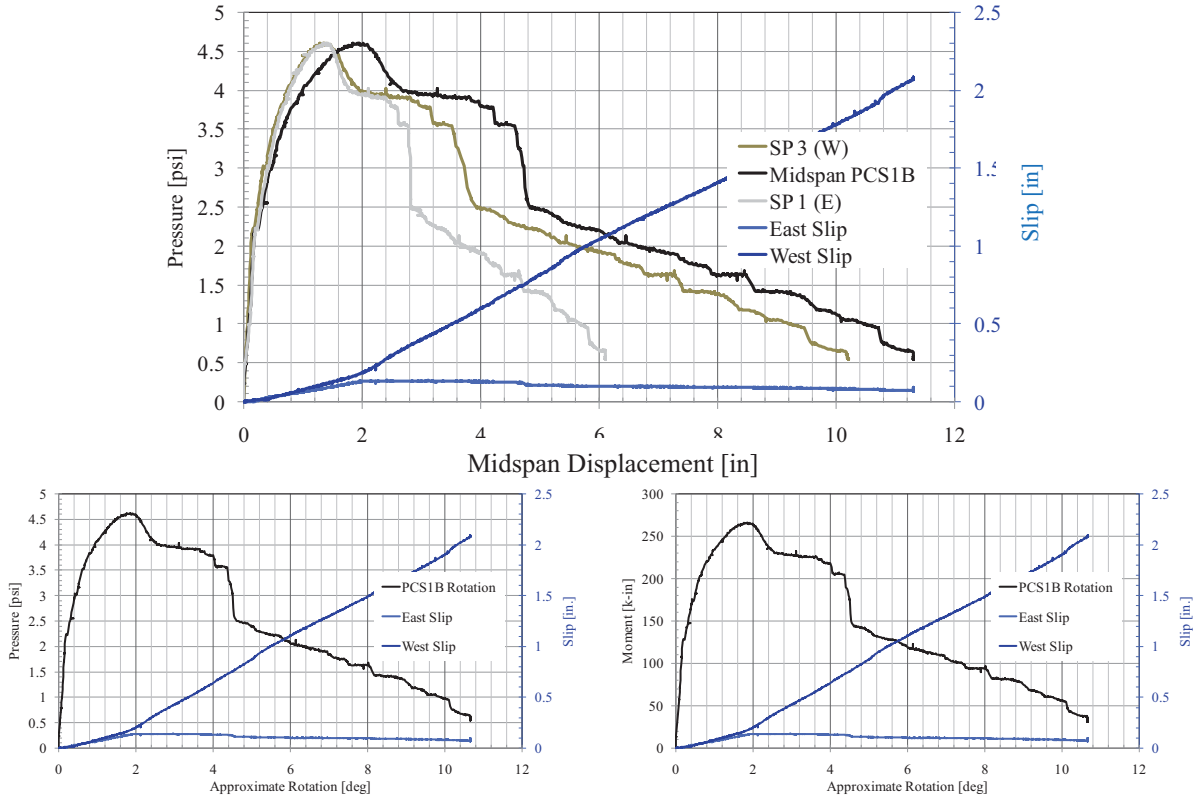

Figure 57. PCS1-B Response

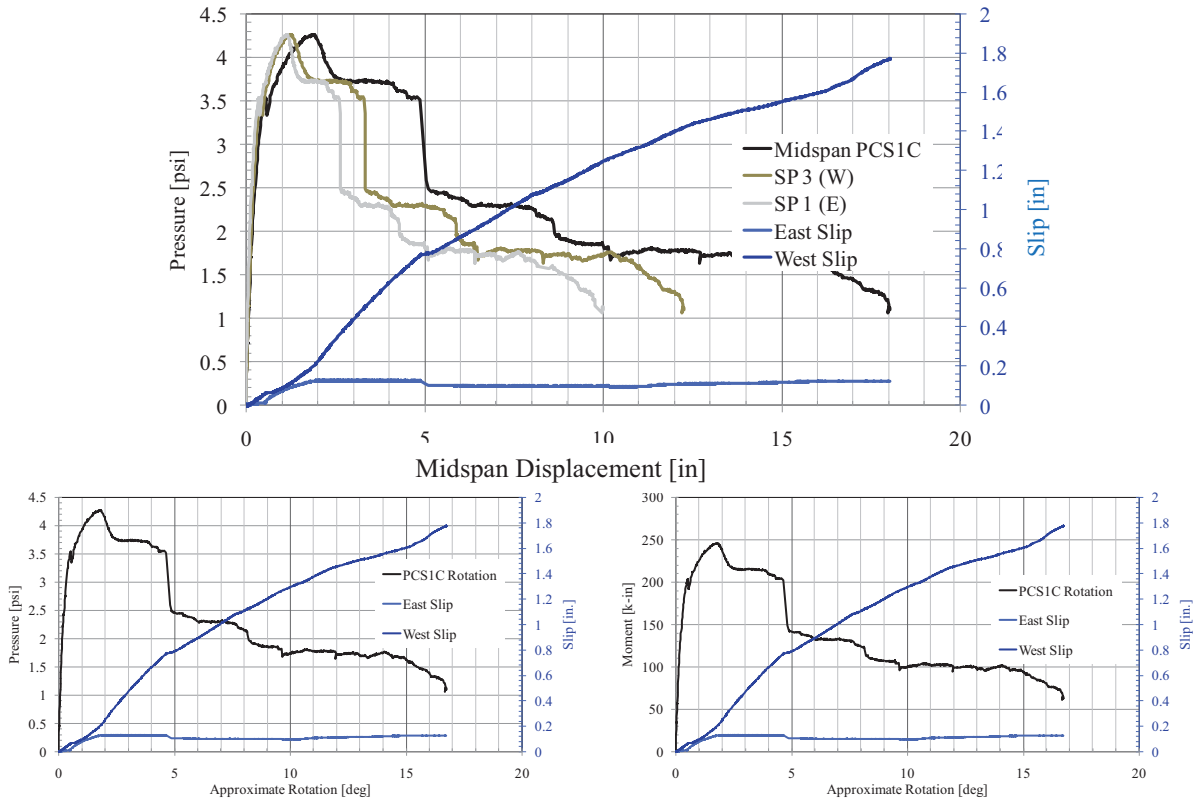

Figure 58. PCS1-C Response



Figure 59. PCS1 Panel Response

6.4. PCS2 3-2-3 Specimen Performance

PCS2 consists of a partially composite 3-2-3 PC CSW panel fabricated with C-Grid® carbon fiber reinforced polymer mesh shear ties. The panel is PS and uses WWR transverse reinforcement in both the interior and exterior wythe. Expanded polystyrene is used. This is the standard insulation recommended for C-Grid® panels. The panel cross-section is illustrated in Figure 60 and Figure 61.

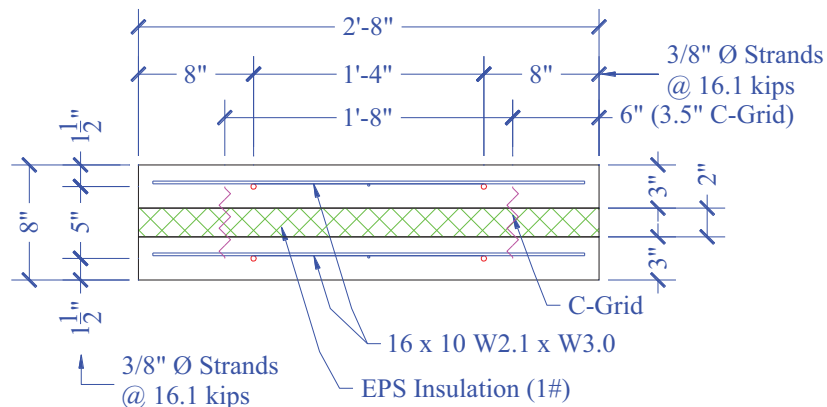

Figure 60. PCS2 Cross-Section Detail

The measured response is summarized in Table 19. The midspan pressure displacement and moment-support rotation for the three specimen are in Figure 62 and Figure 63. The individual response of each panel and the end slip and quarter point displacements are included in Figure 64-66. Figure 67 shows a picture representation of the samples post-test.

Table 19. PCS2 Measured Response

Specimen	Age at Test [days]	Max Load [lbs]	Max Pressure [psi]	Corresponding Displacement [in]	East Slip [in]	West Slip [in]	Rot. [deg]	Measured Moment Capacity [k-in]
PCS2-A	23	20448	5.325	1.990	0.291	0.000	1.900	306.73
PCS2-B	23	19183	4.996	2.309	0.374	0.003	2.204	287.74
PCS2-C	42	19319	5.031	1.345	0.208	0.005	1.284	289.79
Average		19650	5.12	1.88	0.29	0.002	1.80	294.8

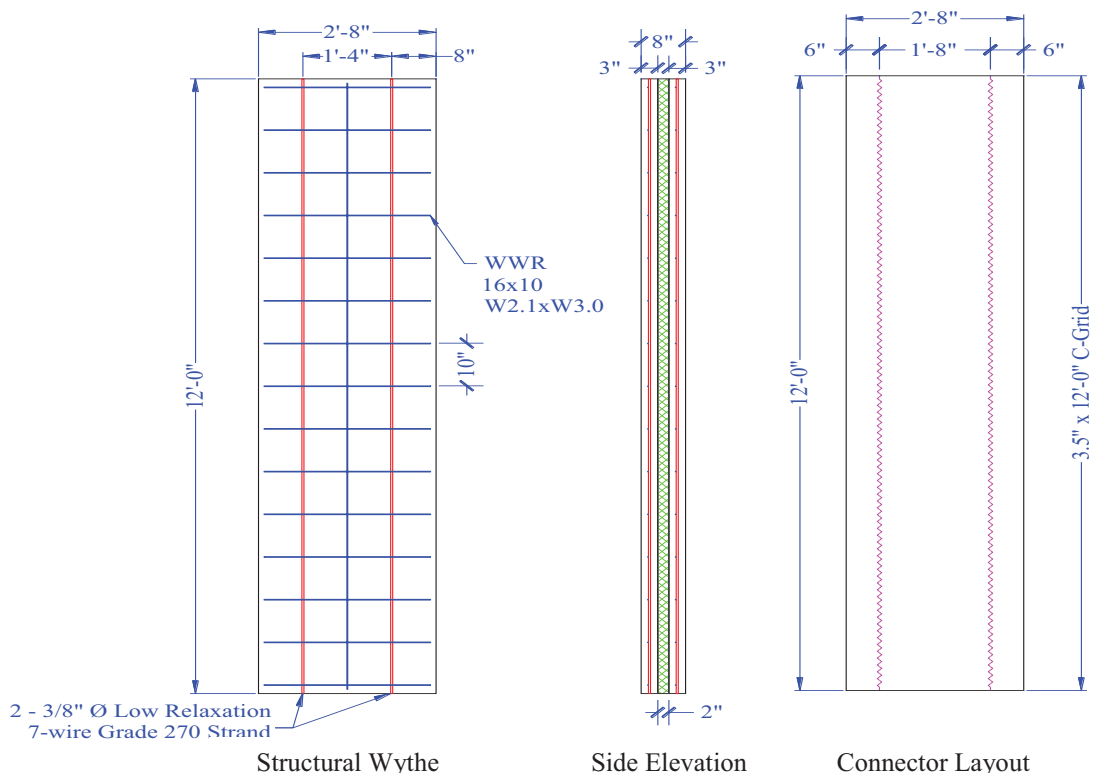

Figure 61. PCS2 Panel Detail

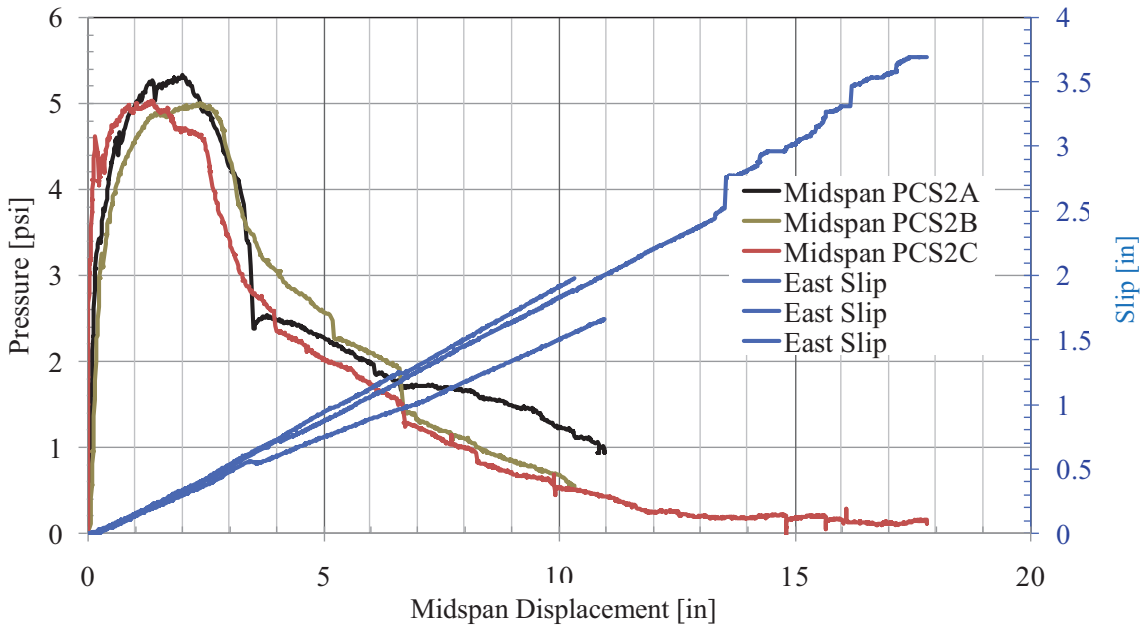

Figure 62. PCS2 Pressure-Displacement Response

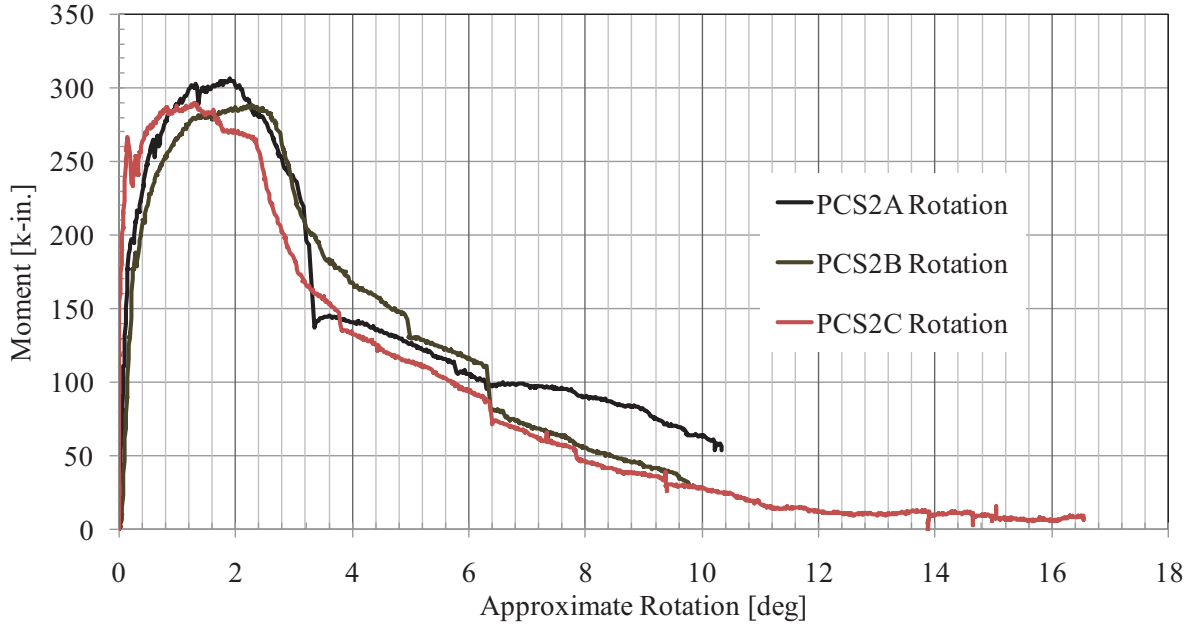

Figure 63. PCS2 Moment-Rotation Response

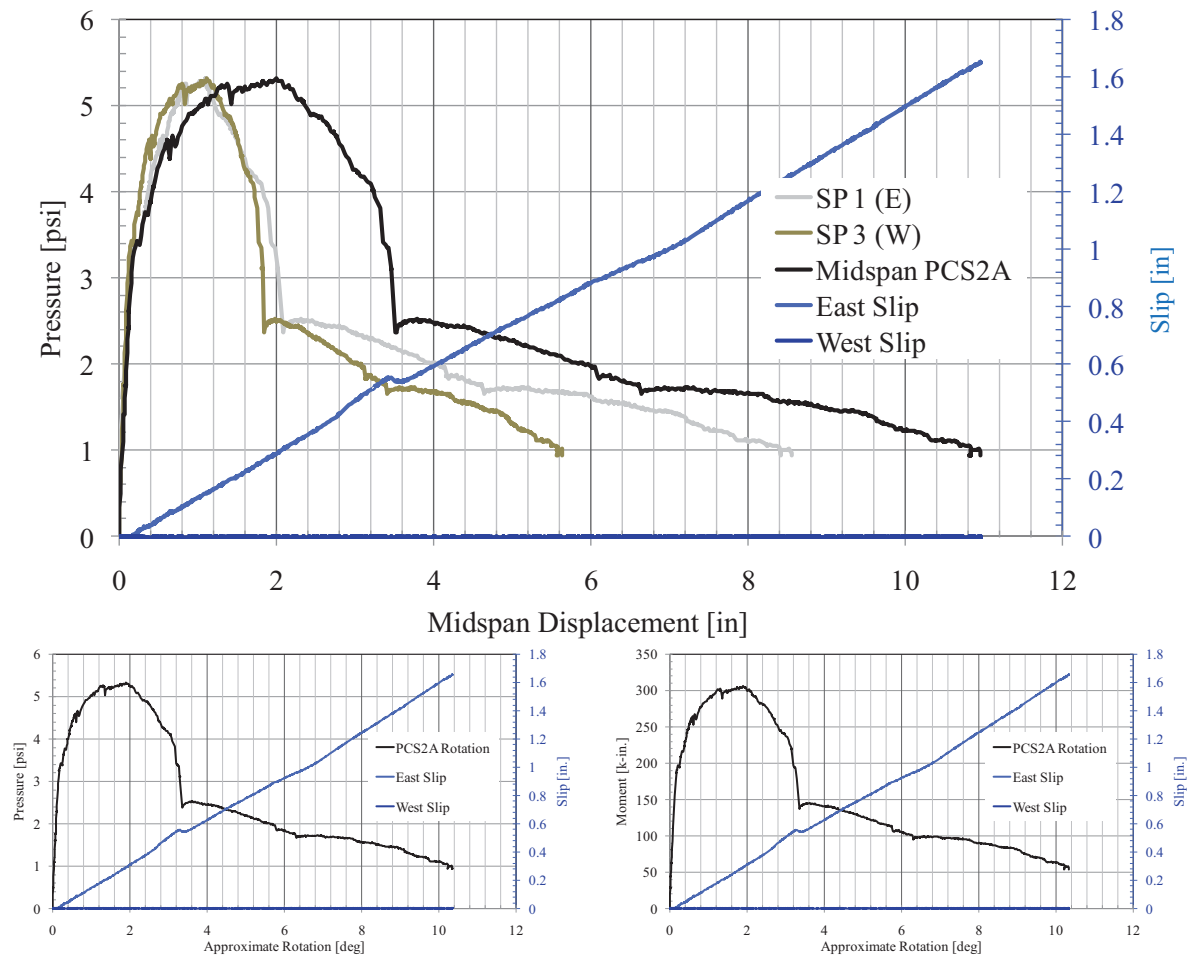

Figure 64. PCS2-A Response

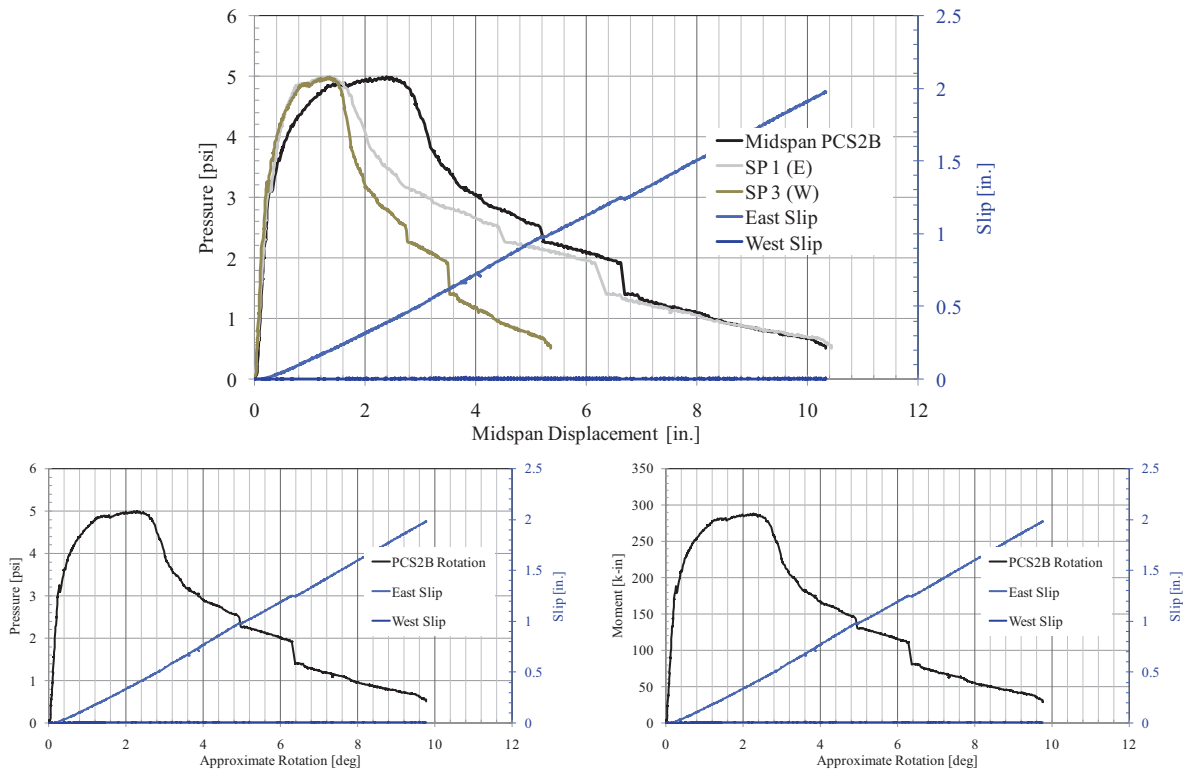

Figure 65. PCS2-B Pressure-Displacement Response

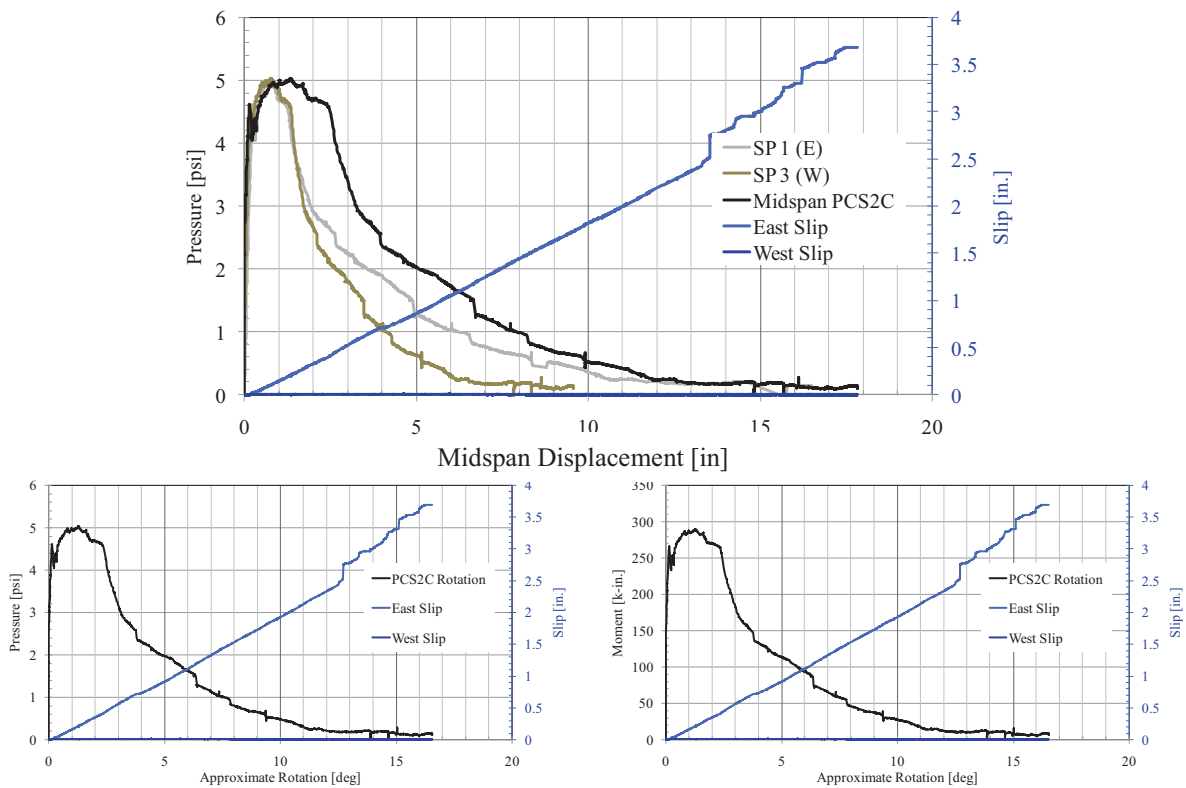

Figure 66. PCS2-C Response



Figure 67. PCS2 Panel Response (A, B, C)

6.5. PCS3 3-2-3 Specimen Performance

PCS3 consists of a partially composite 3-2-3 PC CSW panel fabricated with EPS insulation and steel C-Grid® carbon fiber shear ties. The panel is non-PS with rebar longitudinal reinforcement and WWR transverse reinforcement in both the interior and exterior wythe. The panel cross-section is illustrated in Figure 68 and Figure 69.

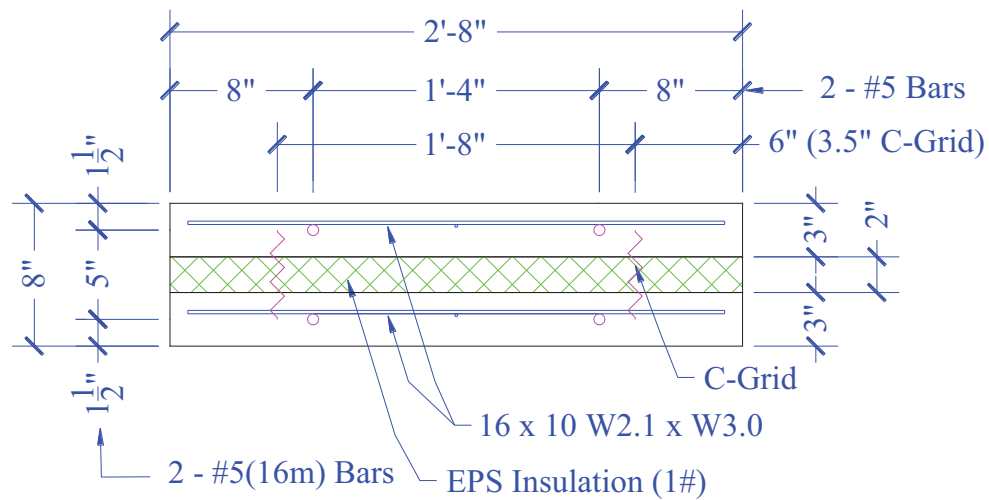

Figure 68. PCS3 Cross-Section Detail

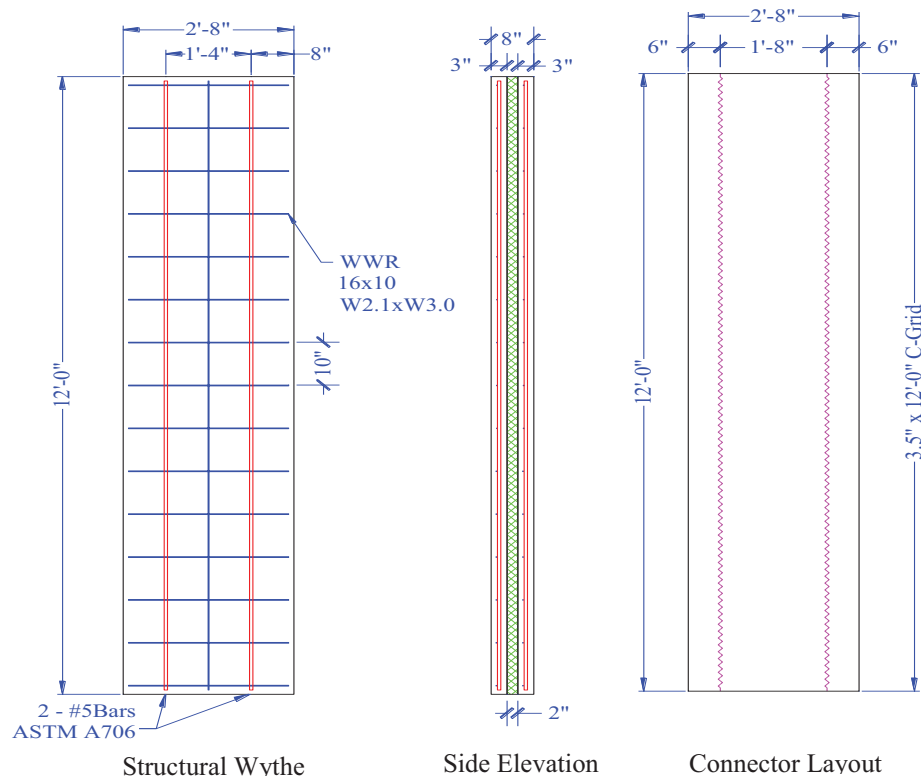

Figure 69. PCS3 Panel Detail

The measured response is summarized in Table 20. The midspan pressure displacement and moment-support rotation for the three specimen are in Figure 70 and Figure 71. The individual response of each panel and the end slip and quarter point displacements are included in Figure 72-74. Figure 75 shows a picture representation of the samples post-test.

Table 20. PCS3 Measured Response

Specimen	Age at Test [days]	Max Load [lbs]	Max Pressure [psi]	Corresponding Displacement [in]	East Slip [in]	West Slip [in]	Rot. [deg]	Measured Moment Capacity [k-in]
PCS3-A	22	21256	5.536	6.000	0.016	0.008	5.711	318.85
PCS3-B	26	16328	4.252	0.892	0.041	0.002	0.852	244.92
PCS3-C	41	23643	6.157	5.500	0.001	0.090	5.237	354.64
Average		20409	5.31	4.13	0.02	0.03	3.93	306.1

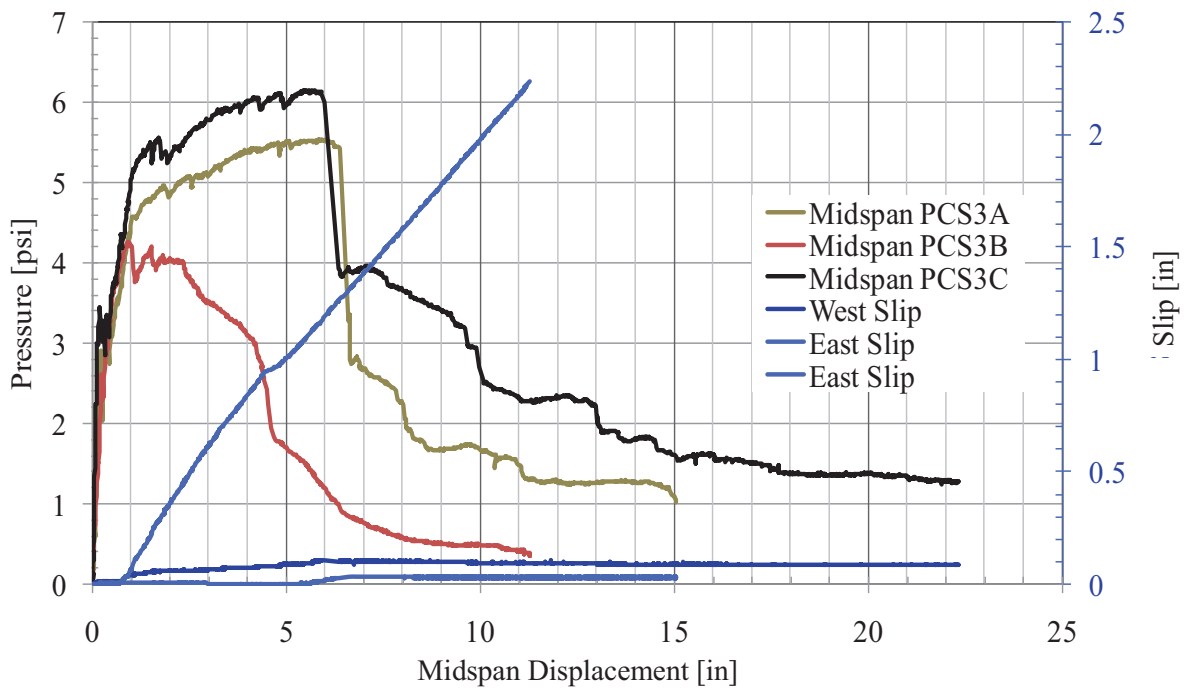

Figure 70. PCS3 Pressure-Displacement Response

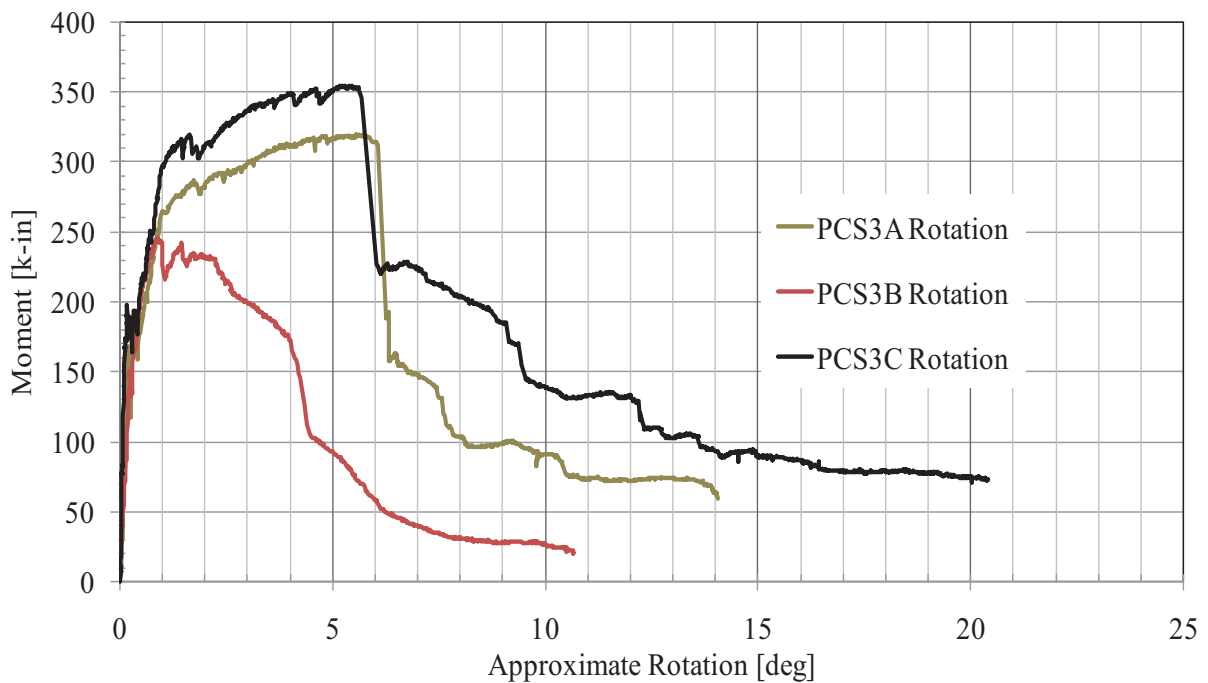

Figure 71. PCS3 Moment-Rotation Response

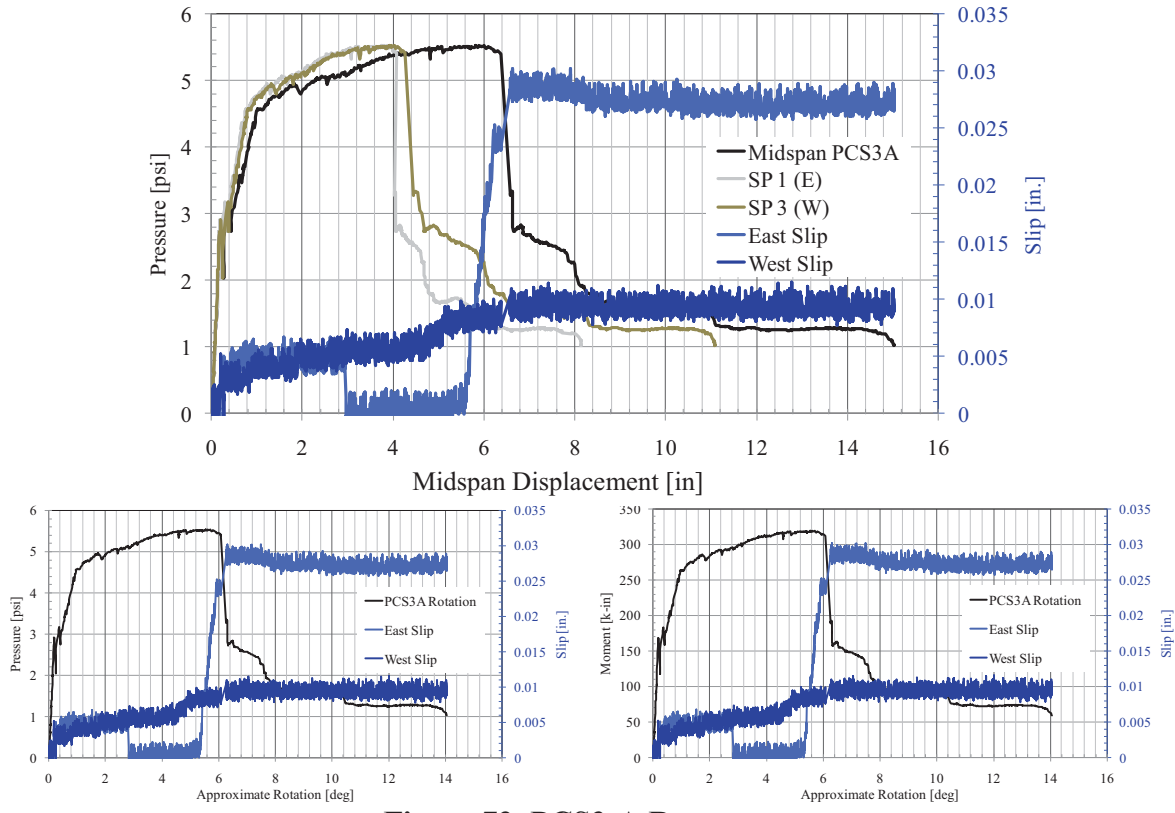

Figure 72. PCS3-A Response

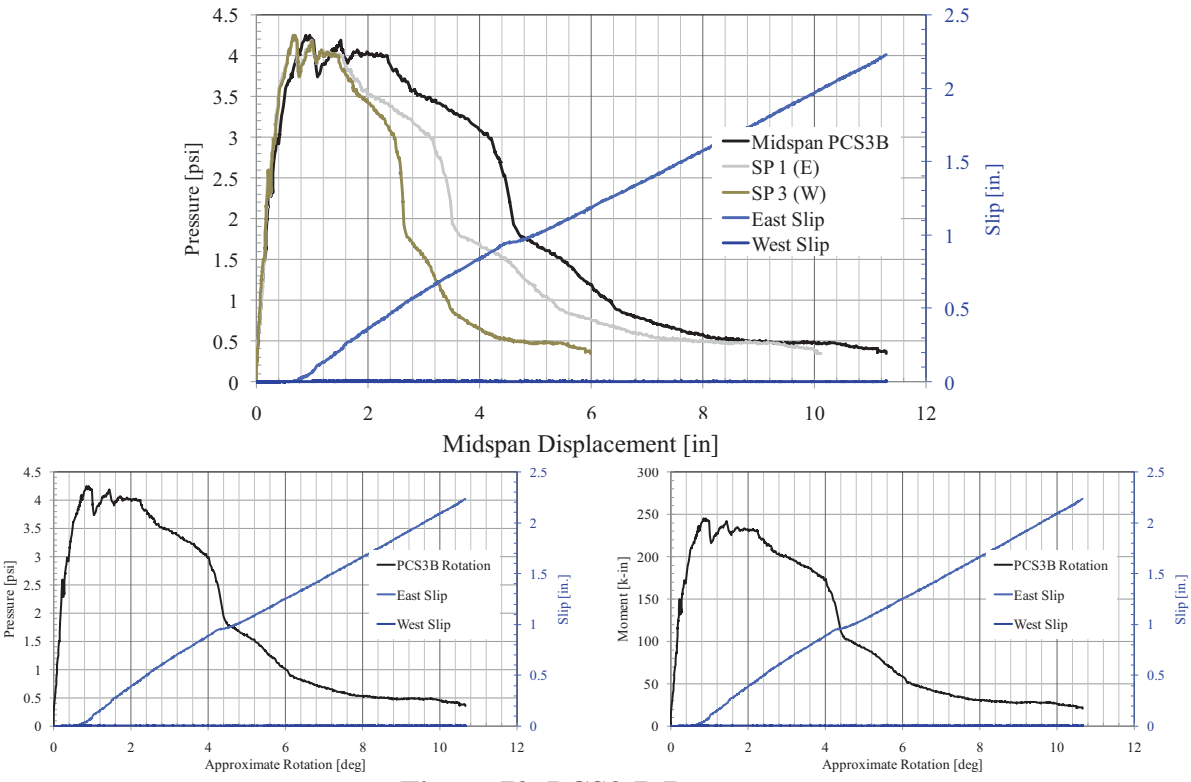

Figure 73. PCS3-B Response

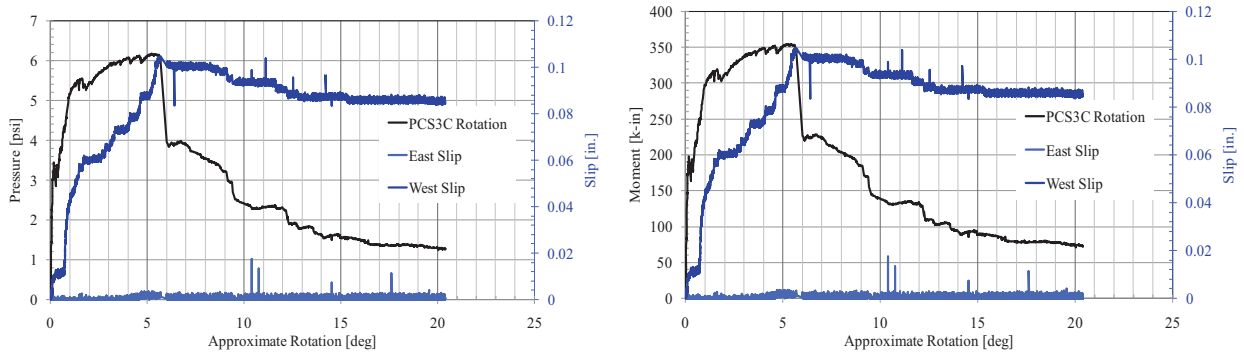
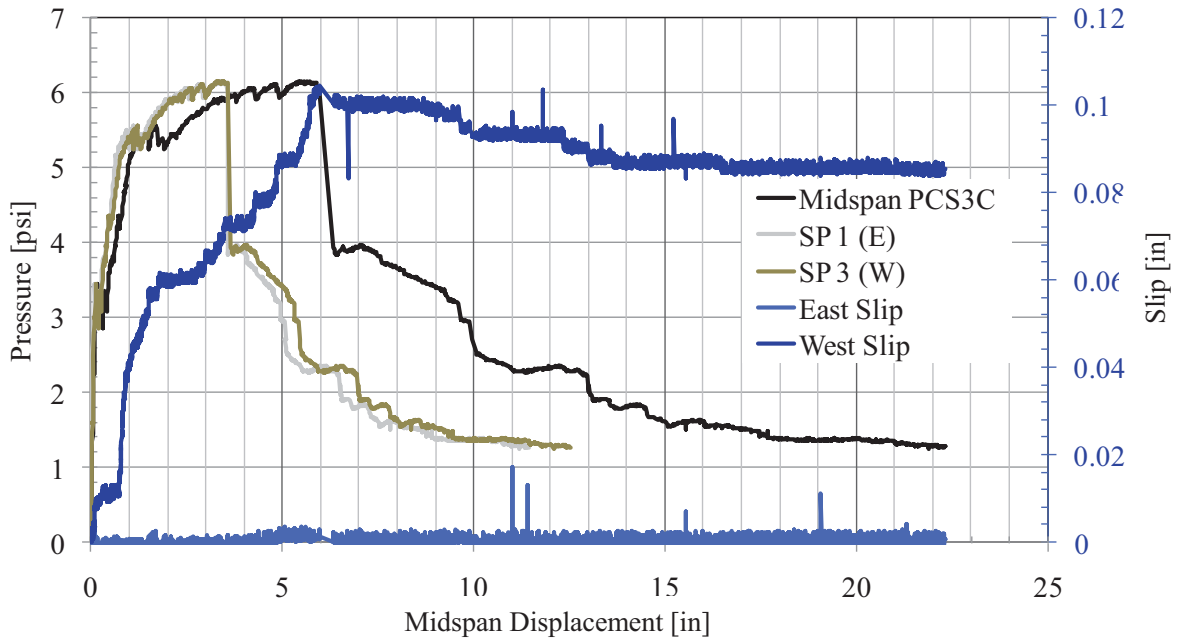

Figure 74. PCS3-C Response



Figure 75. PCS3 Panel Response (A, B, C)

6.6. PCS3 (Type 2) 3-2-3 Specimen Performance

PCS3 (Type 2) consists of a partially composite 3-2-3 PC CSW panel fabricated with EPS insulation and steel C-clip shear ties. The panel contains both prestressing and conventional non-PS longitudinal reinforcement with WWR transverse reinforcement in both the interior and exterior wythe. The panel cross-section and reinforcement details are illustrated in Figure 76 and Figure 77.

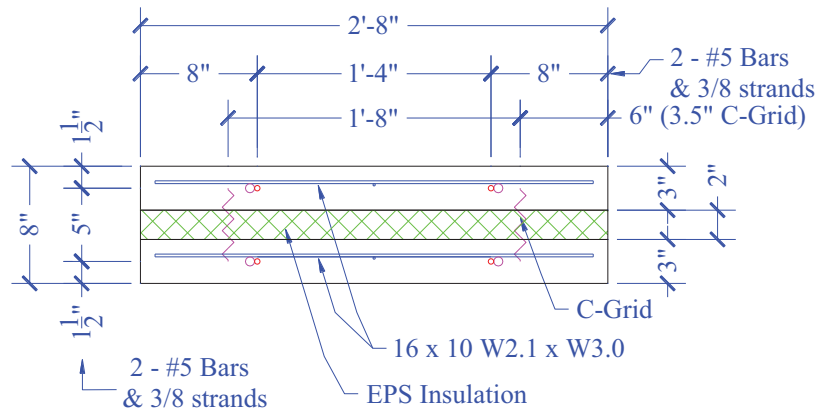

Figure 76. PCS3 (Type 2) Cross-Section Detail

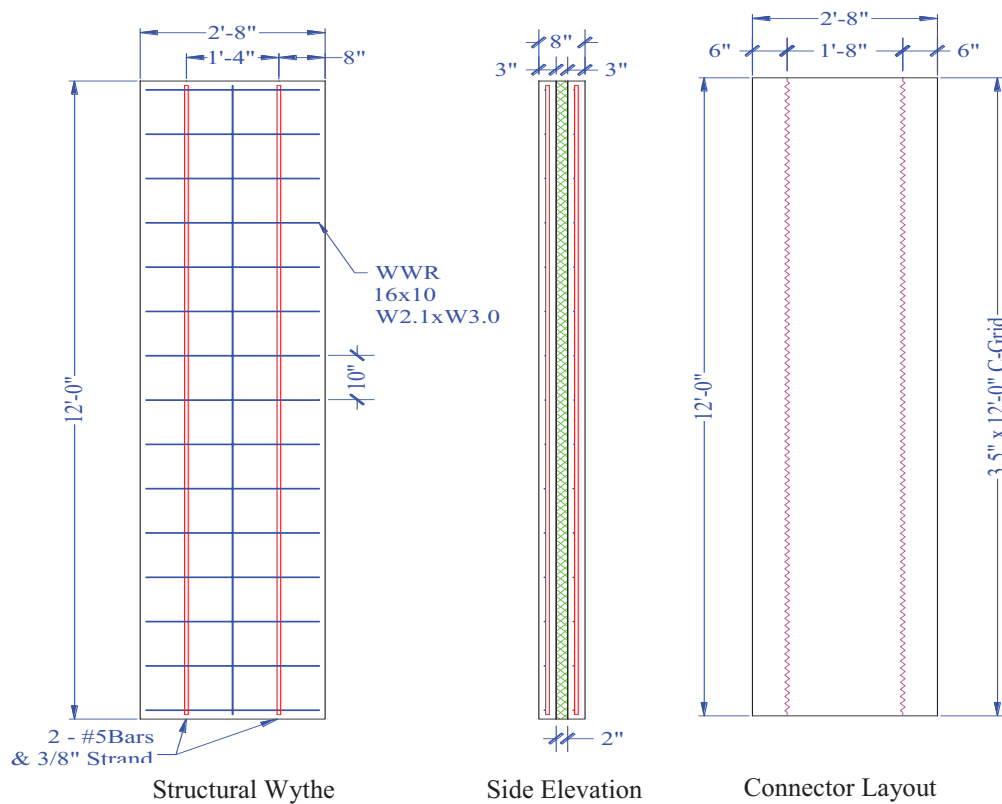

Figure 77. PCS3 (Type 2) Panel Detail

The measured response is summarized in Table 21. The midspan pressure displacement and moment–support rotation for the three specimen are in Figure 78 and Figure 79. The individual response of each panel and the end slip and quarter point displacements are included in Figure 80-82. Figure 83 shows a picture representation of the samples post-test.

Table 21. PCS3 (Type 2) Measured Response

Specimen	Age at Test [days]	Max Load [lbs]	Max Pressure [psi]	Corresponding Displacement [in]	East Slip [in]	West Slip [in]	Rot. [deg]	Measured Moment Capacity [k-in]
PCS3-D	36	21886	5.699	5.544	0.695	0.368	5.279	328.28
PCS3-E	43	23645	6.157	5.320	0.652	0.358	5.067	354.67
PCS3-F	43	20956	5.457	3.896	0.000	0.762	3.716	314.34
Average		22162	5.77	4.92	0.45	0.50	4.69	332.4

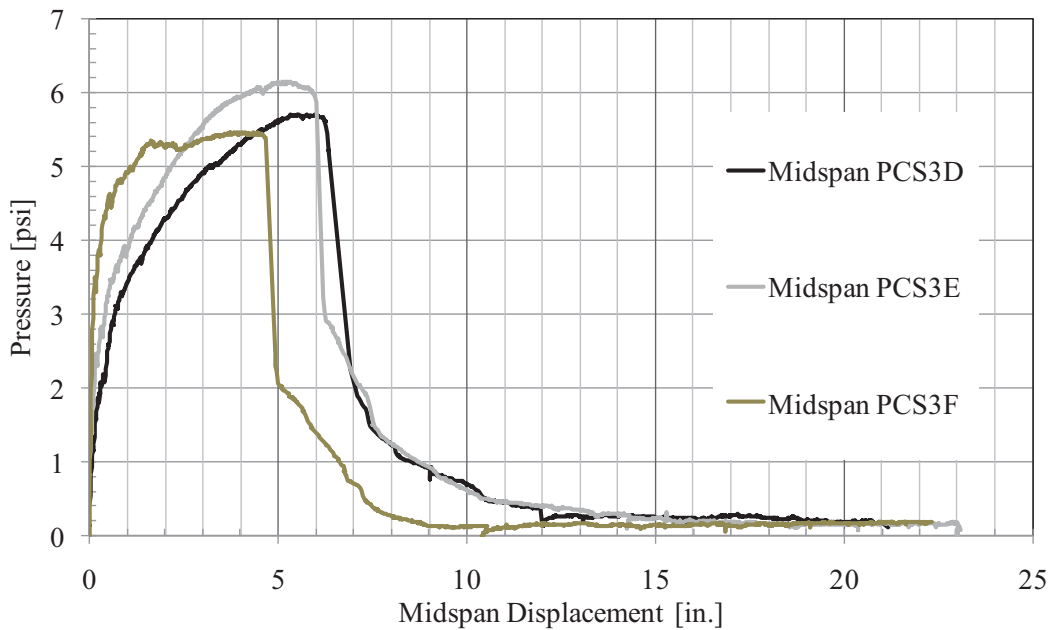

Figure 78. PCS3 (Type 2) Pressure–Displacement Response

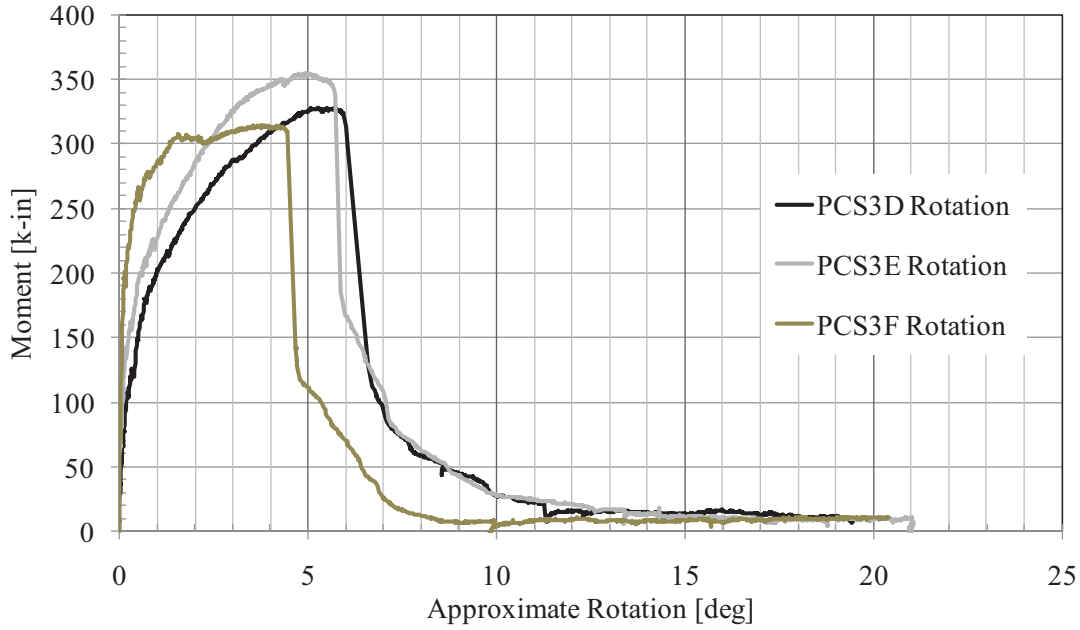

Figure 79. PCS3 (Type 2) Moment-Rotation Response

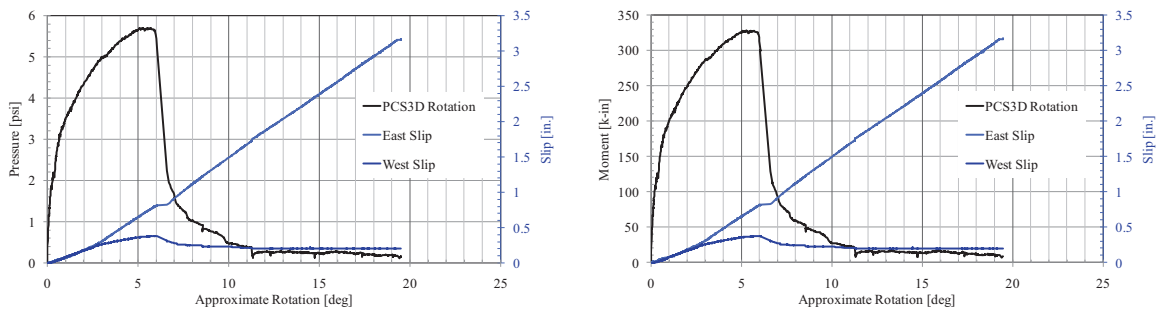
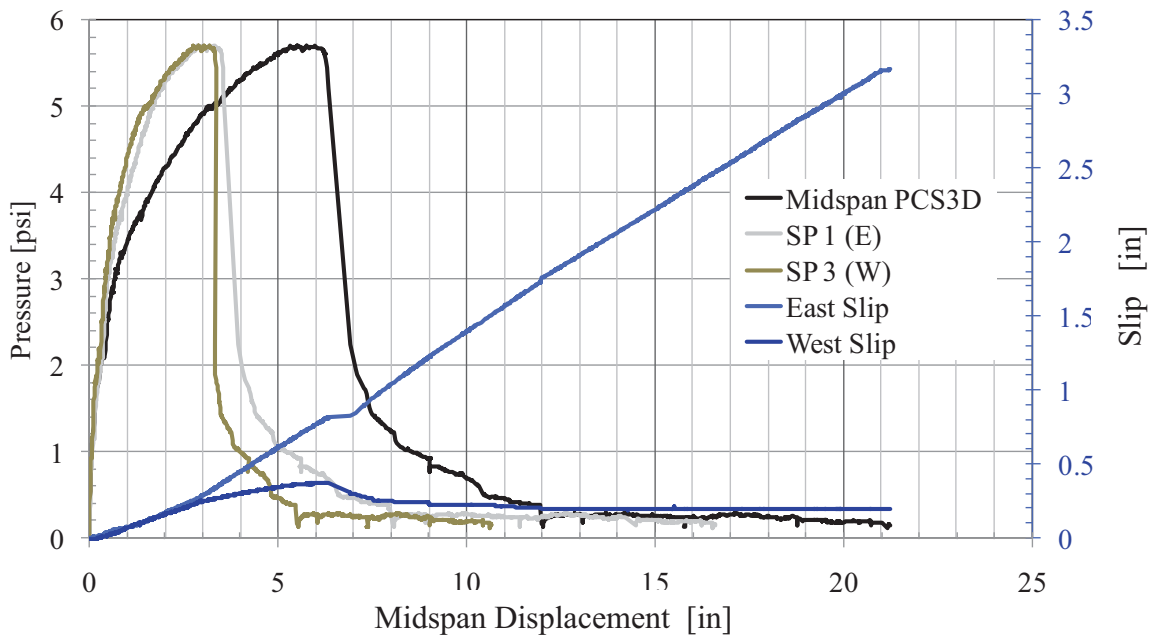

Figure 80. PCS3-D Response

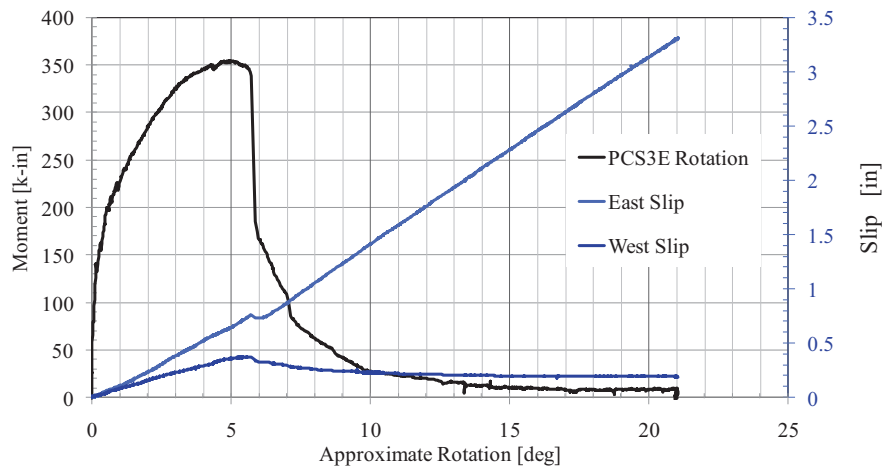
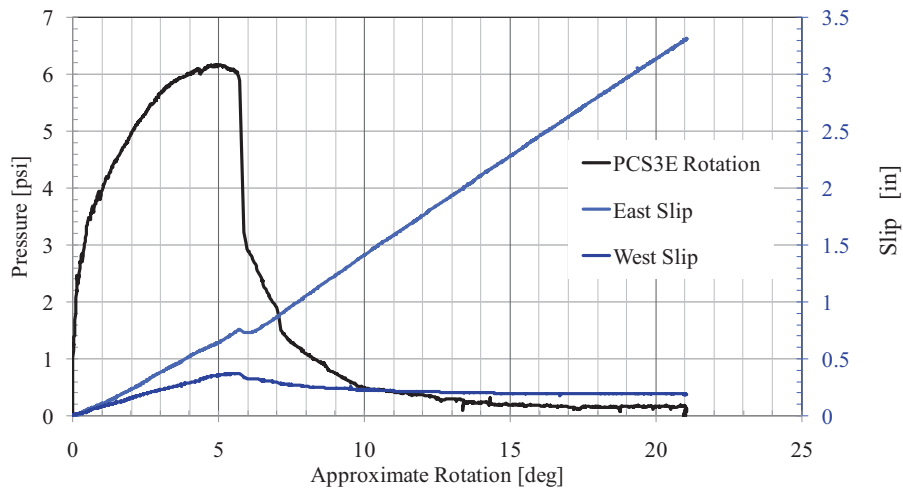
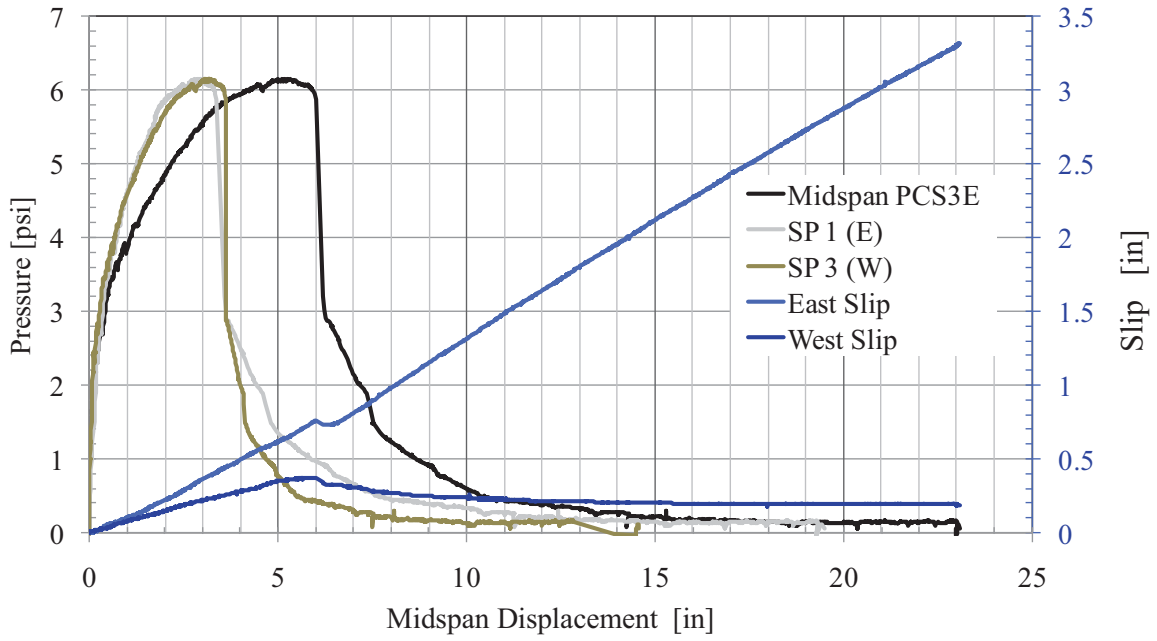

Figure 81. PCS3-E Response

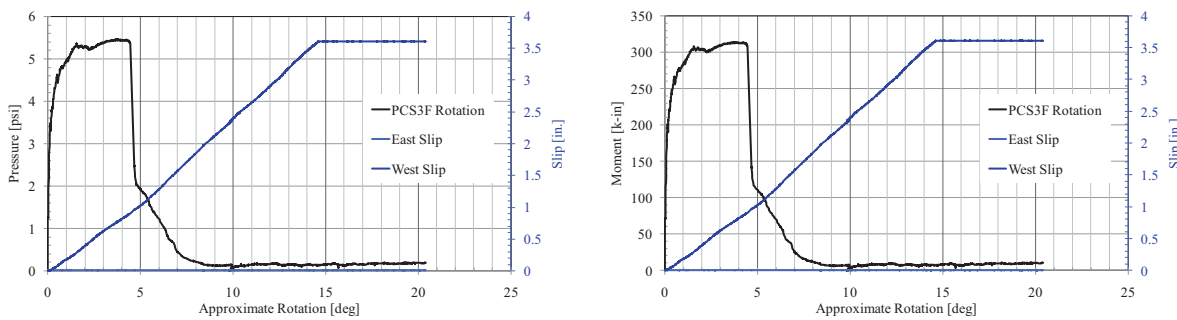
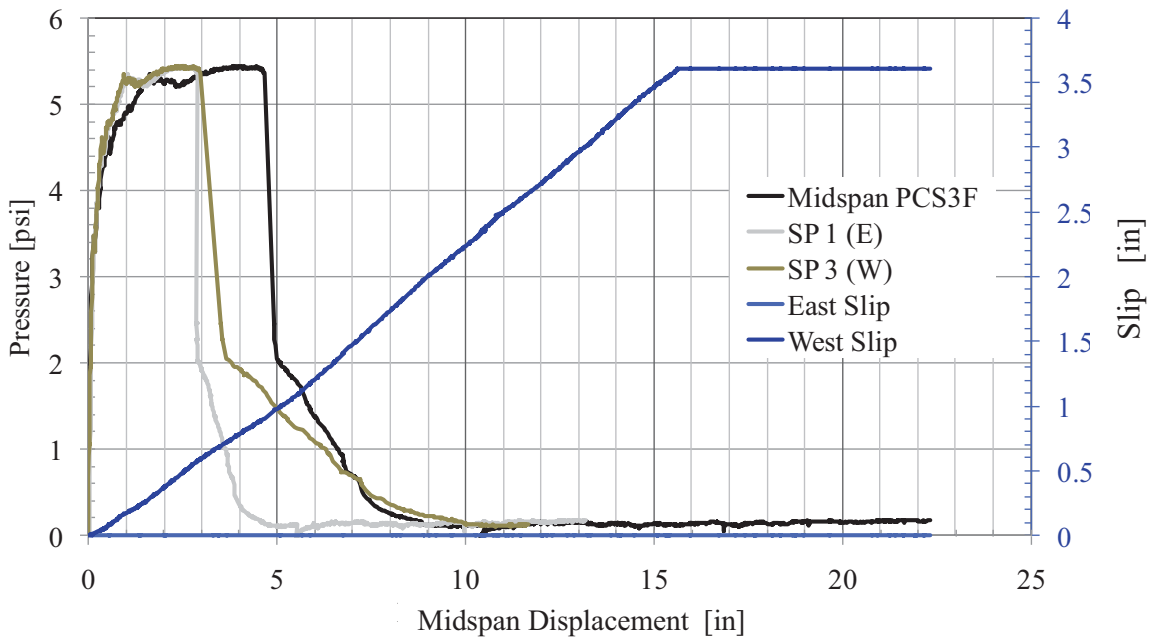

Figure 82. PCS3-F Response



Figure 83. PCS3 (Type 2) Panel Response (D, E, F)

6.7. PCS4 3-3-3 Specimen Performance

PCS4 consists of a partially composite 3-3-3 PC CSW panel fabricated with XPS insulation and steel C-clip shear ties. The panel is PS with rebar transverse reinforcement in both the interior and exterior wythe. The panel cross-section and reinforcement details are illustrated in Figure 84-86.

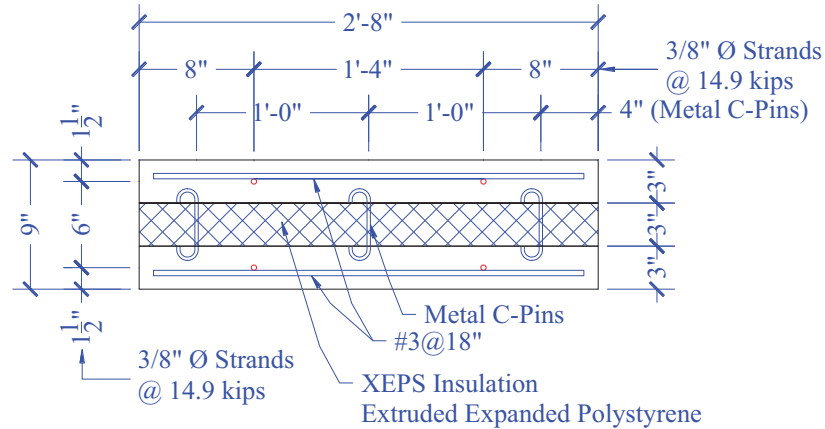

Figure 84. PCS4 Cross-Section Detail

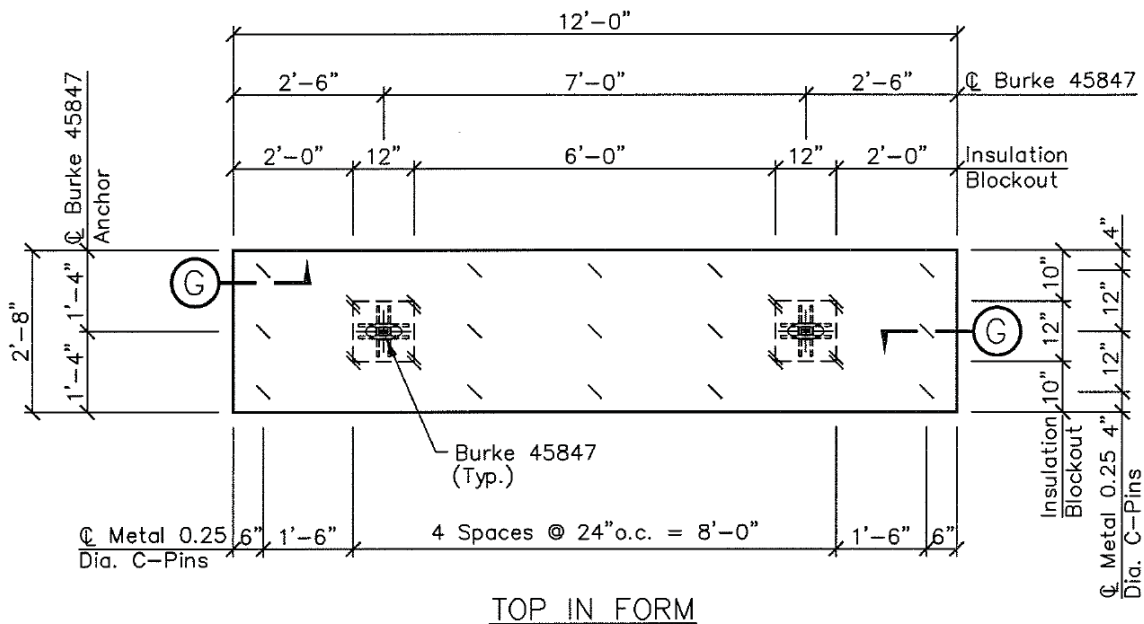

Figure 85. PCS4 Panel Detail

The material properties for the specimen and the measured response are summarized in Table 22 and Table 23. The midspan pressure displacement and moment–support rotation for the three specimen follow in Figure 87 and Figure 88. The individual response of each panel and the quarter point displacements are included at the end in Figures 89-91. Figure 92 shows a picture representation of the three samples post-test.

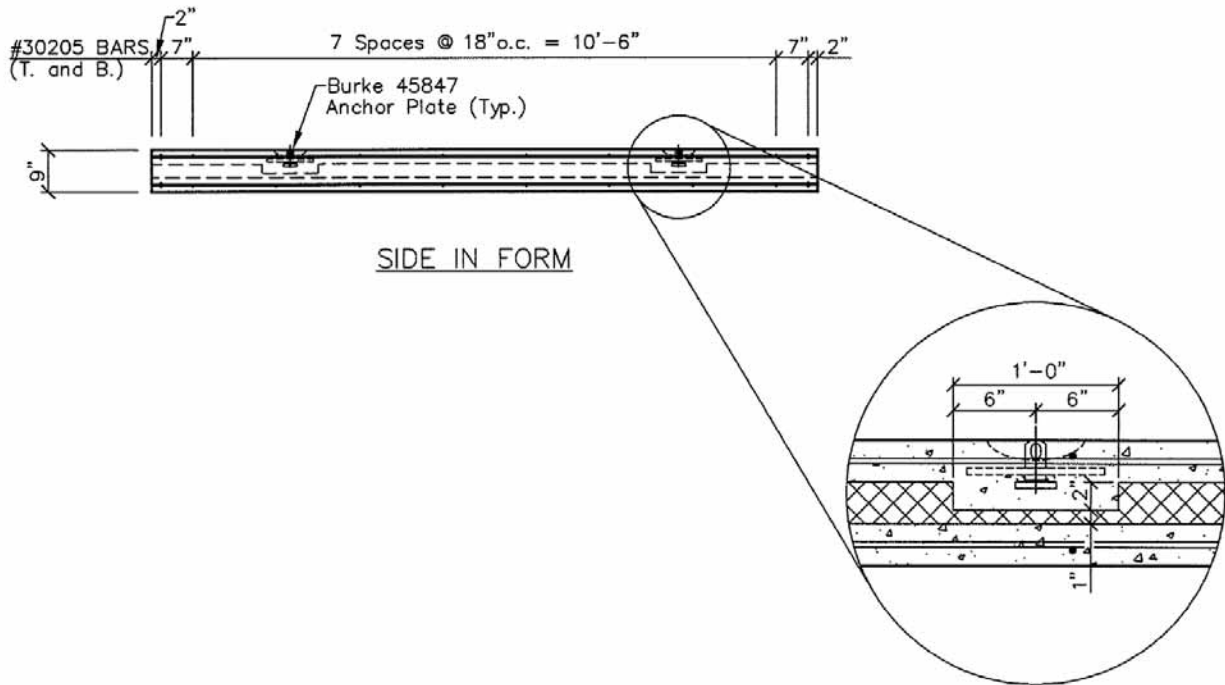

Figure 86. PCS4 Panel Detail 2

Table 22. PCS4 Material Properties

Property	Value
Design Unit Weight	150 lb/ft ³
Design Compression Strength at Release, f_{ci}	3500 psi
Design Compressive Strength at 28 days, f'_c	5000 psi
Approximate Compressive Strength PCS4-A	8873 psi
Approximate Compressive Strength PCS4-B	8793 psi
Approximate Compressive Strength PCS4-C	8793 psi

Table 23. PCS4 Measured Response

Specimen	Age at Test [days]	Max Load [lbs]	Max Pressure [psi]	Corresponding Displacement [in]	East Slip [in]	West Slip [in]	Rot. [deg]	Measured Moment Capacity [k-in]
PCS4-A	100	18410	4.794	6.943	0.673	0.897	6.601	276.14
PCS4-B	109	16138	4.203	5.408	0.250	0.974	5.151	242.07
PCS4-C	109	19110	4.976	6.355	0.512	0.909	6.046	286.65
Average		17886	4.66	6.24	0.48	0.93	5.93	268.3

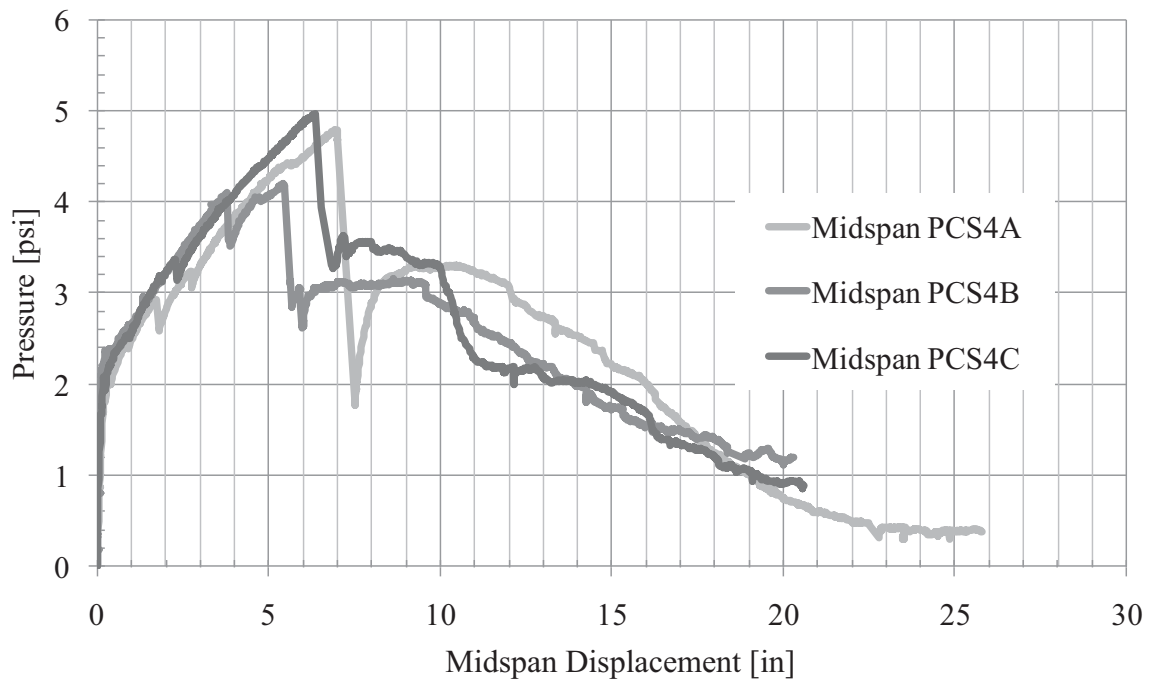

Figure 87. PCS4 Pressure-Displacement Response

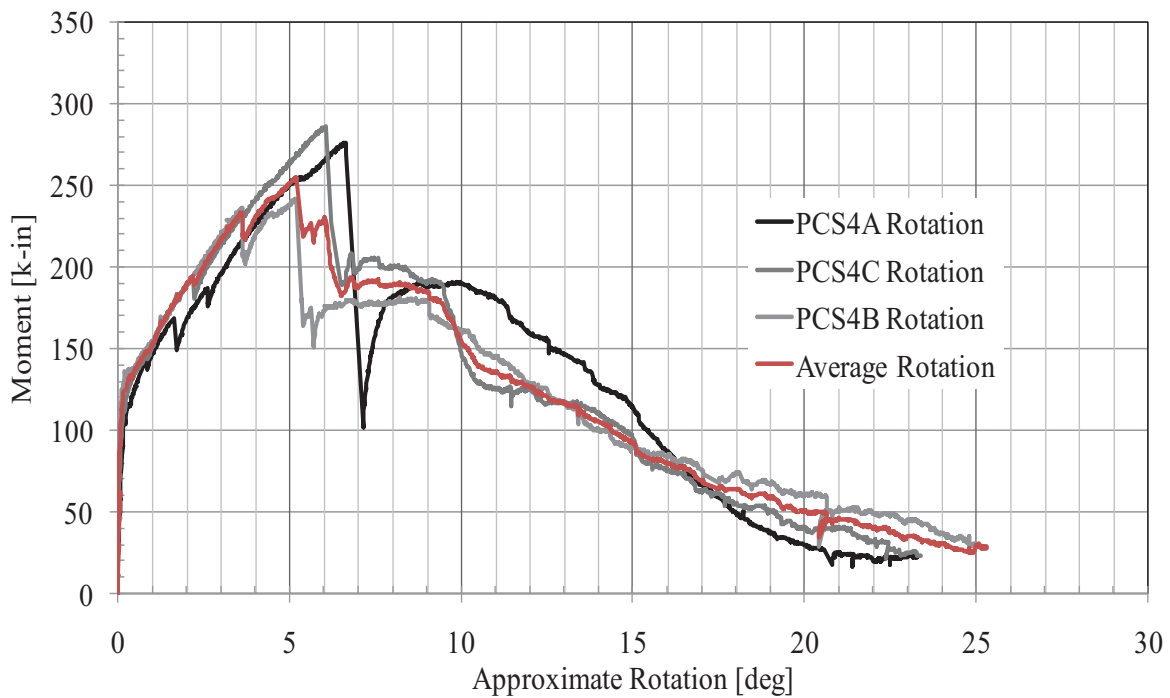

Figure 88. PCS4 Moment-Rotation Response

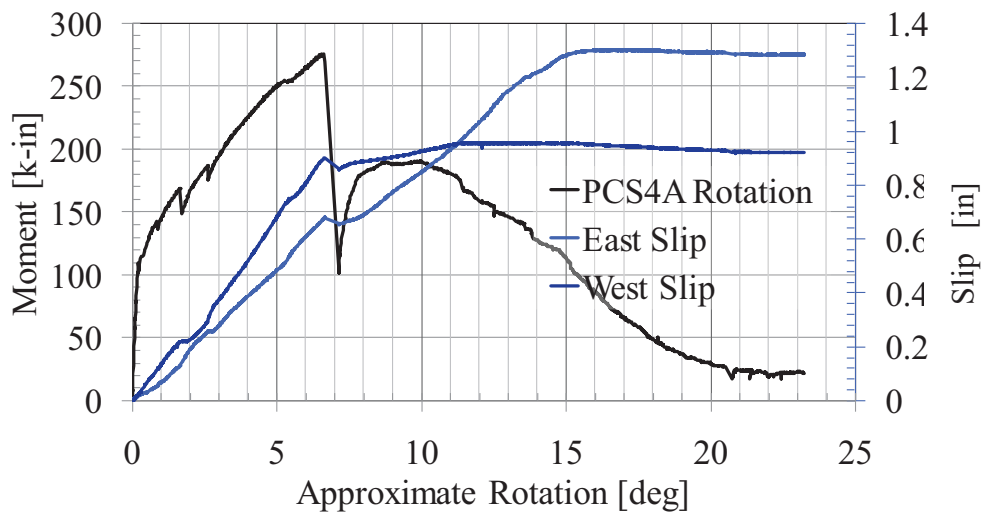
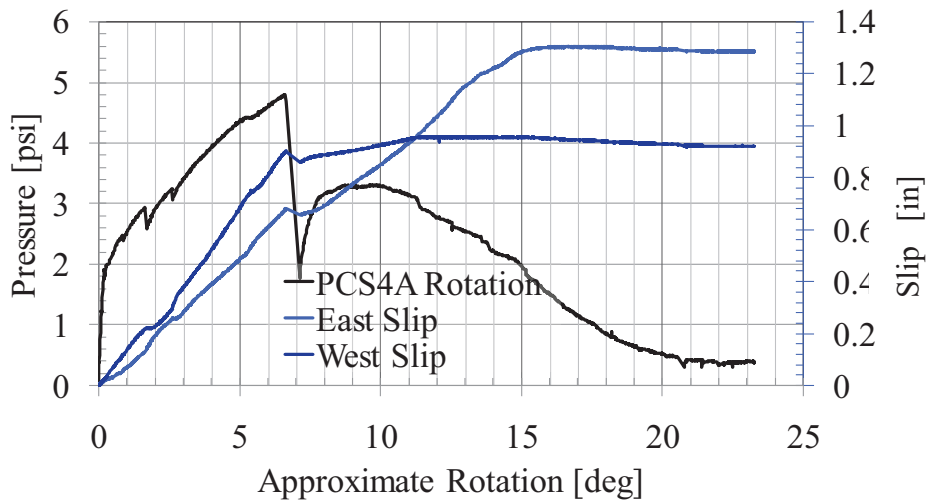
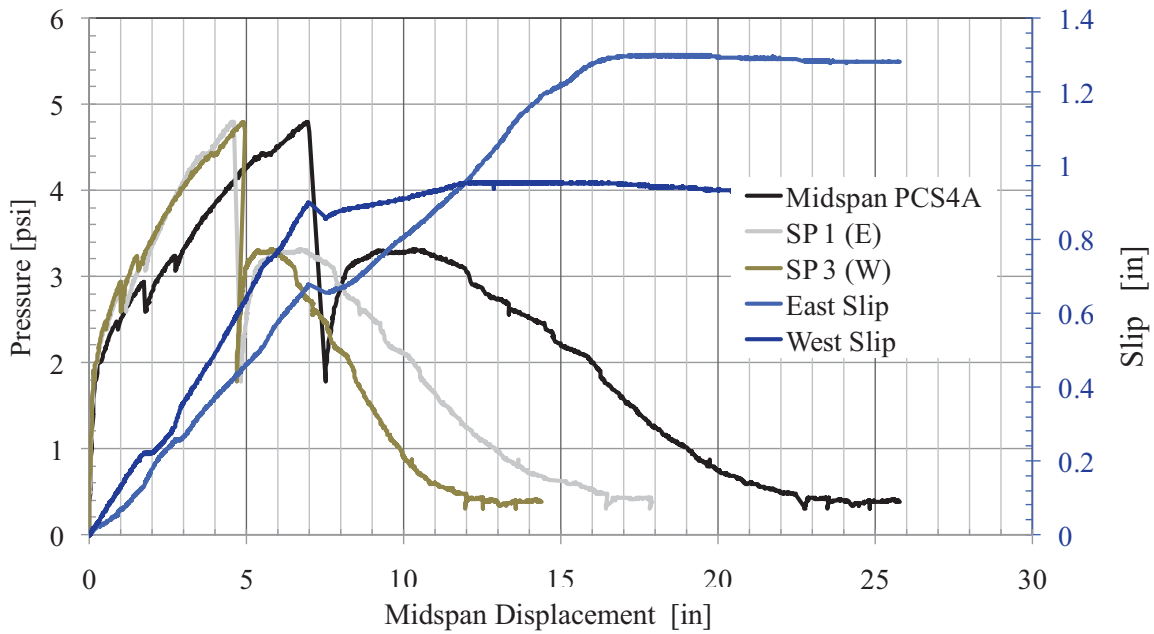

Figure 89. PCS4-A Response

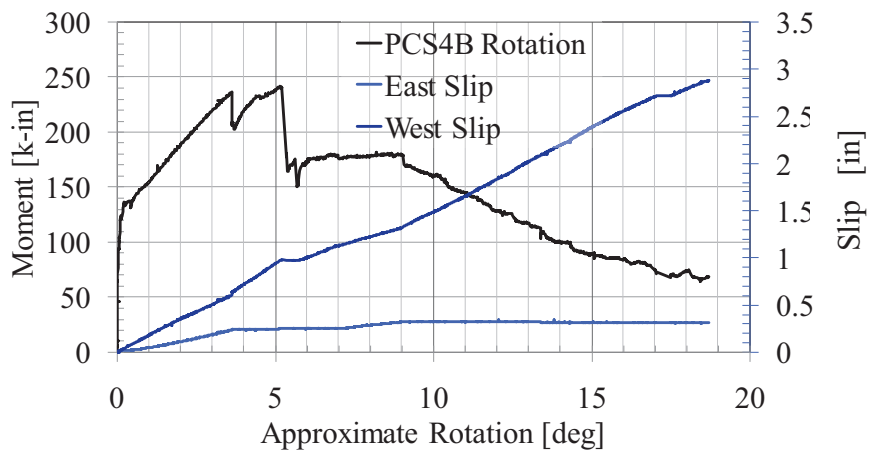
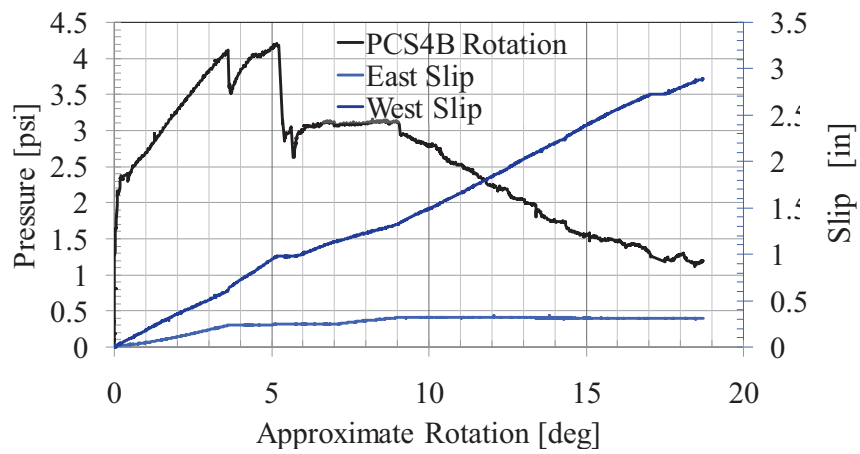
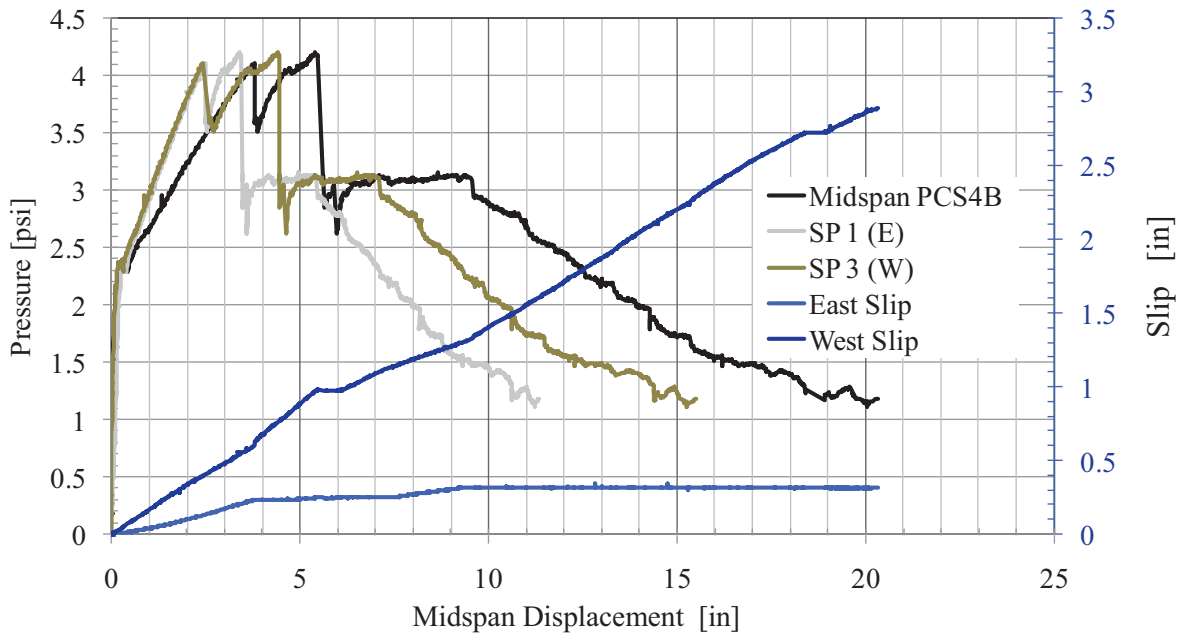

Figure 90. PCS4-B Response

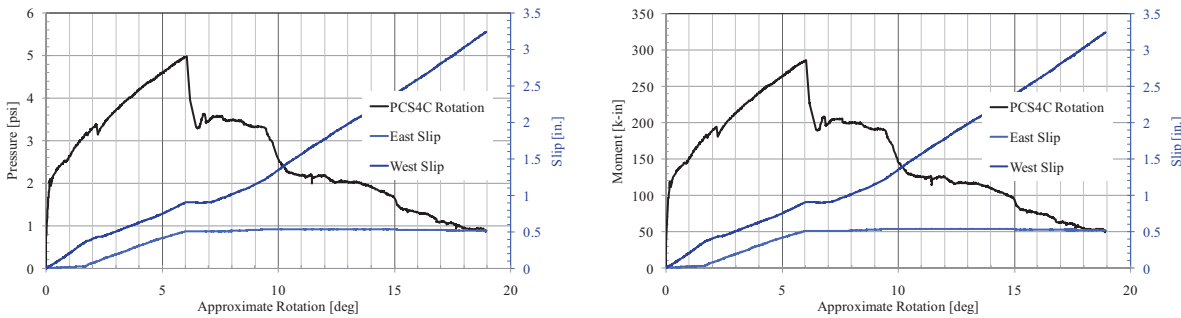
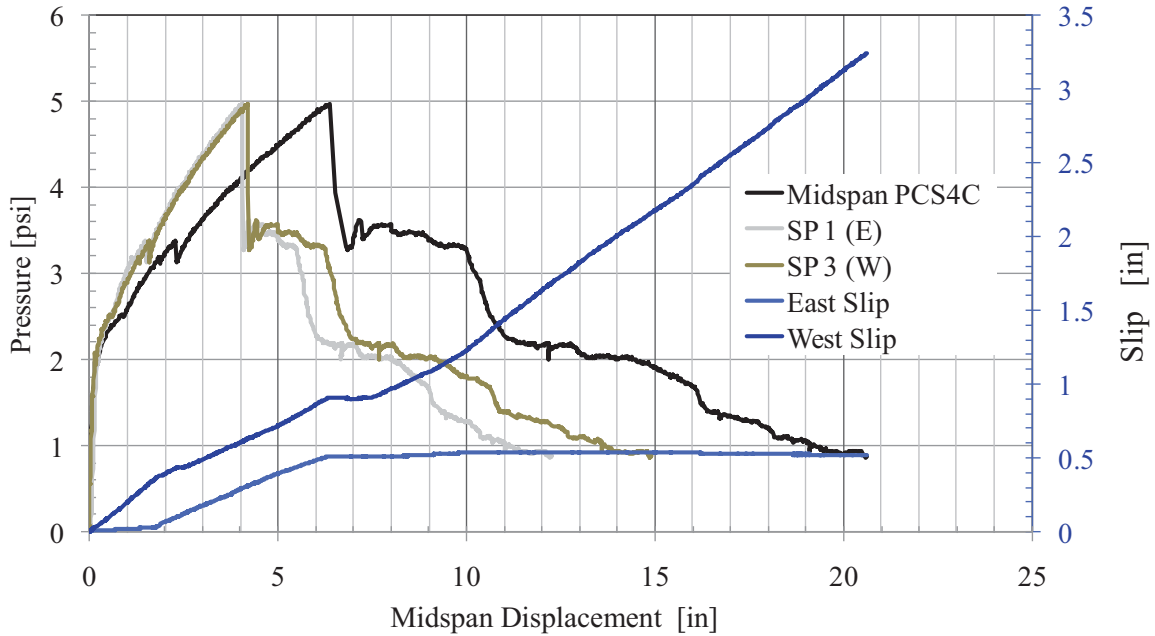

Figure 91. PCS4-C Response



Figure 92. PCS4 Panel Response (A, B, C)

6.8. PCS5 3-3-3 Specimen Performance

PCS5 consists of a partially composite 3-3-3 PC CSW panel fabricated with XPS insulation and glass fiber THERMOMASS® composite shear pins. The panel is PS with rebar transverse reinforcement in both the interior and exterior wythe. The panel cross-section and reinforcement details are illustrated in Figure 93 and Figure 94.

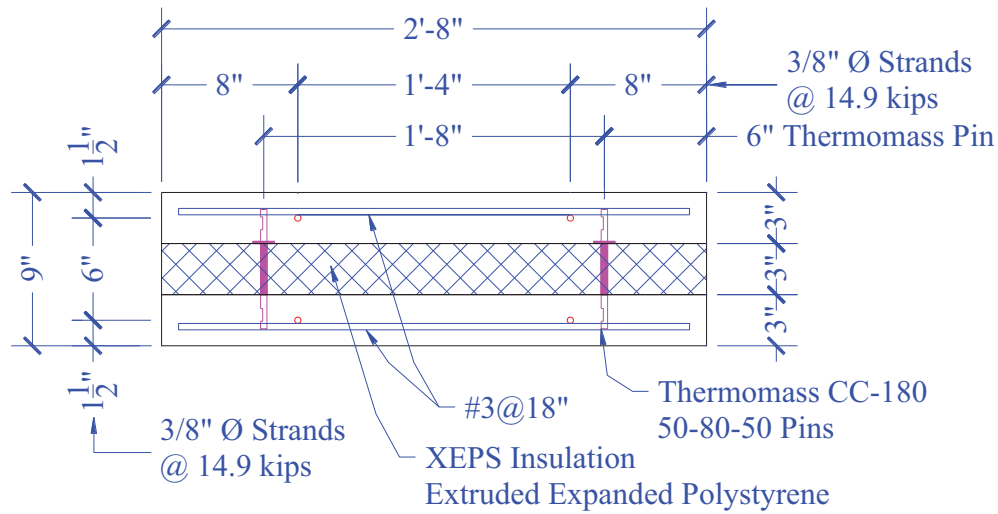

Figure 93. PCS5 Cross-Section Detail

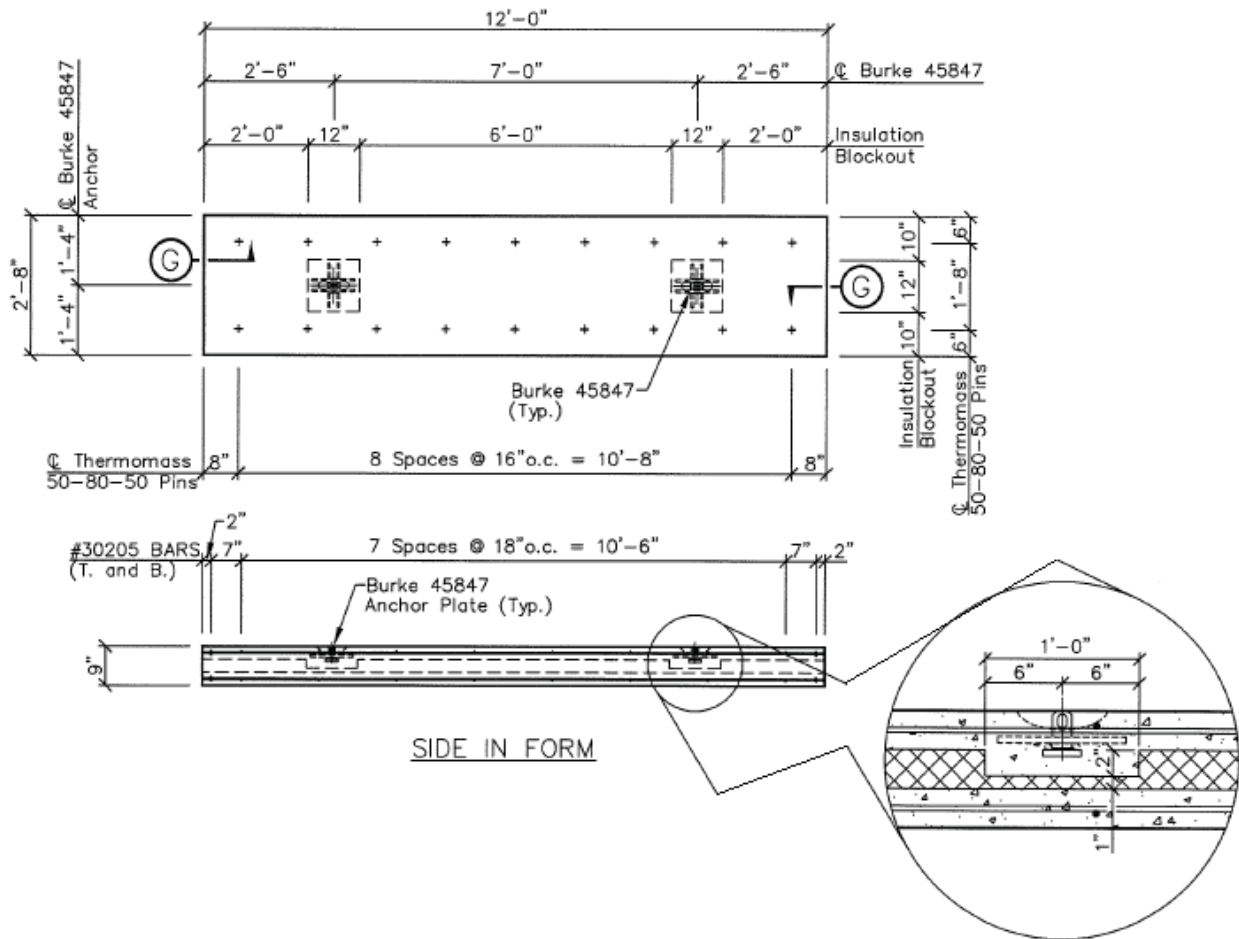

Figure 94. PCS5 Panel Detail

The measured response is summarized in Table 24. The midspan pressure displacement and moment–support rotation for the three specimen are in Figure 95 and Figure 96. The individual response of each panel and the end slip and quarter point displacements are included in Figure 97-99. Figure 100 shows a picture representation of the samples post-test.

Table 24. PCS5 Measured Response

Specimen	Age at Test [days]	Max Load [lbs]	Max Pressure [psi]	Corresponding Displacement [in]	East Slip [in]	West Slip [in]	Rot. [deg]	Measured Moment Capacity [k-in]
PCS5-A	101	17770	4.628	4.765	0.527	0.604	4.541	266.55
PCS5-B	112	19910	5.185	5.118	0.500	0.562	4.875	298.65
PCS5-C	113	18252	4.753	5.536	0.633	0.637	5.272	273.78
Average		18644	4.86	5.14	0.55	0.60	4.90	279.7

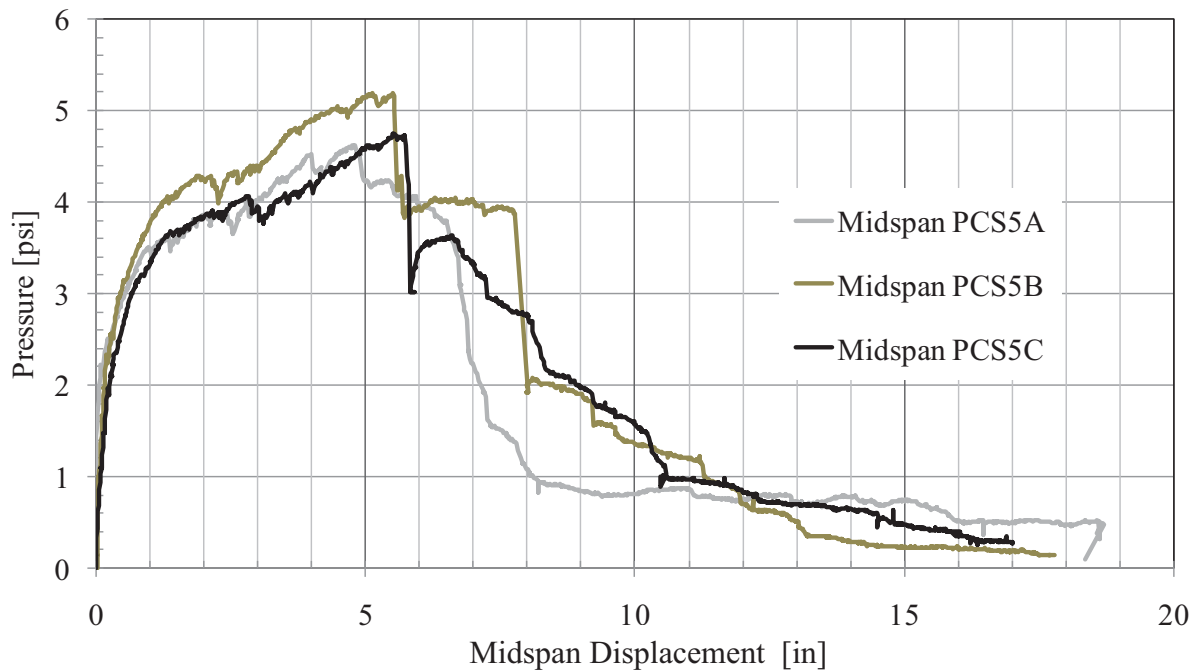

Figure 95. PCS5 Pressure–Displacement Response

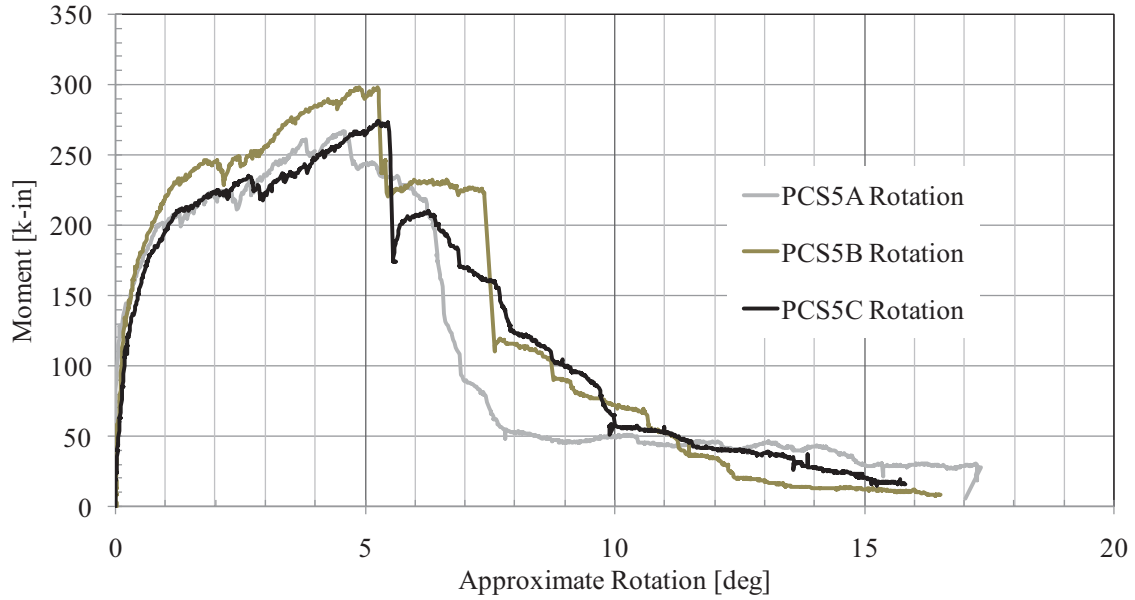

Figure 96. PCS5 Moment-Rotation Response

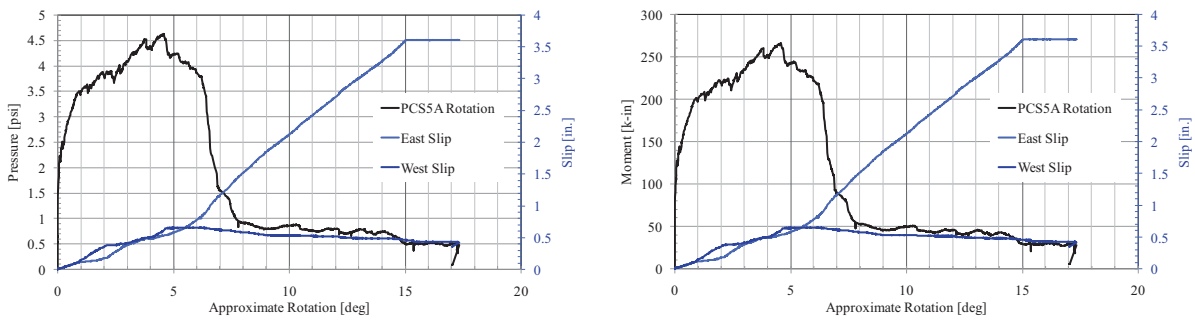
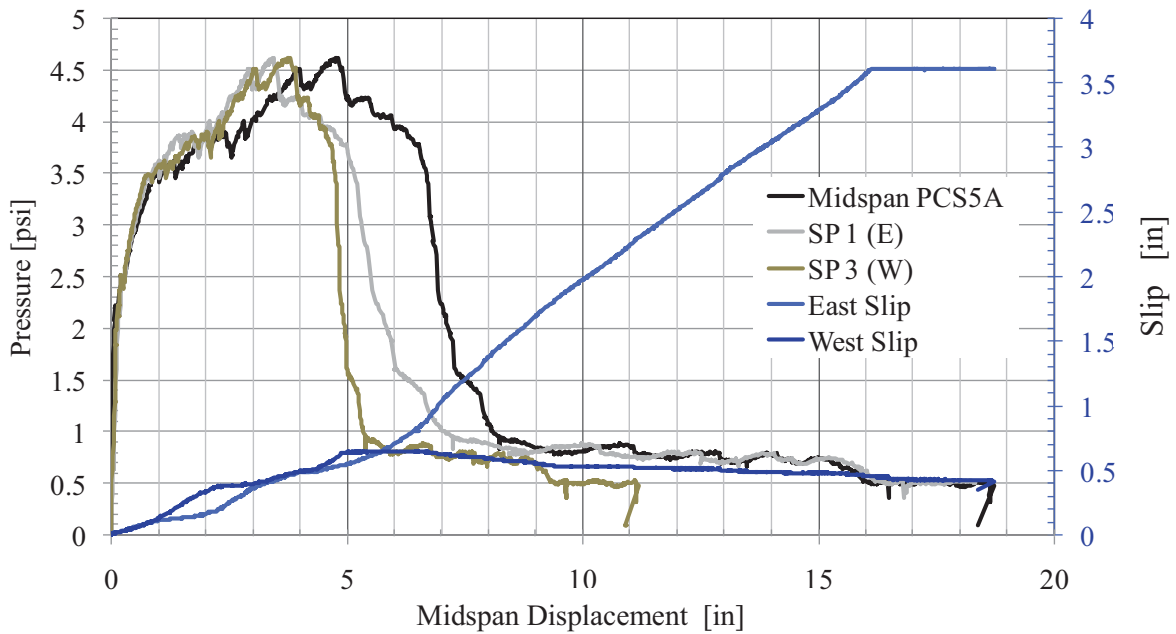

Figure 97. PCS5-A Response

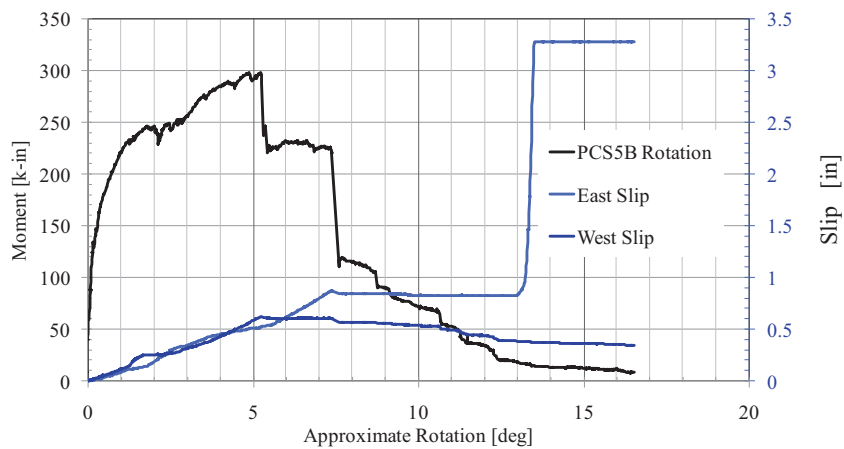
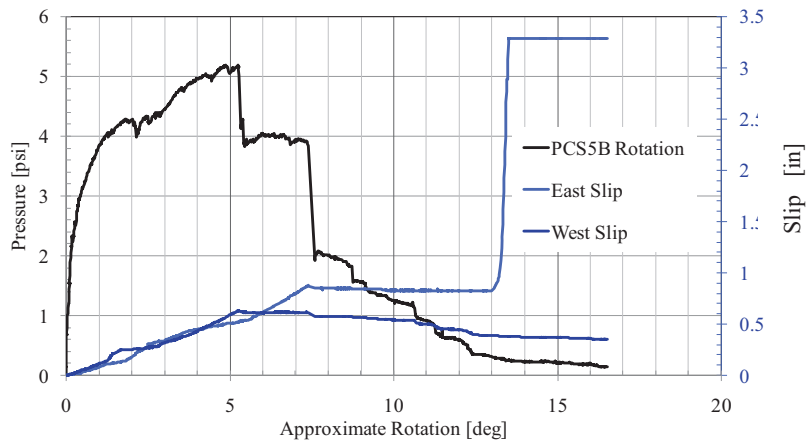
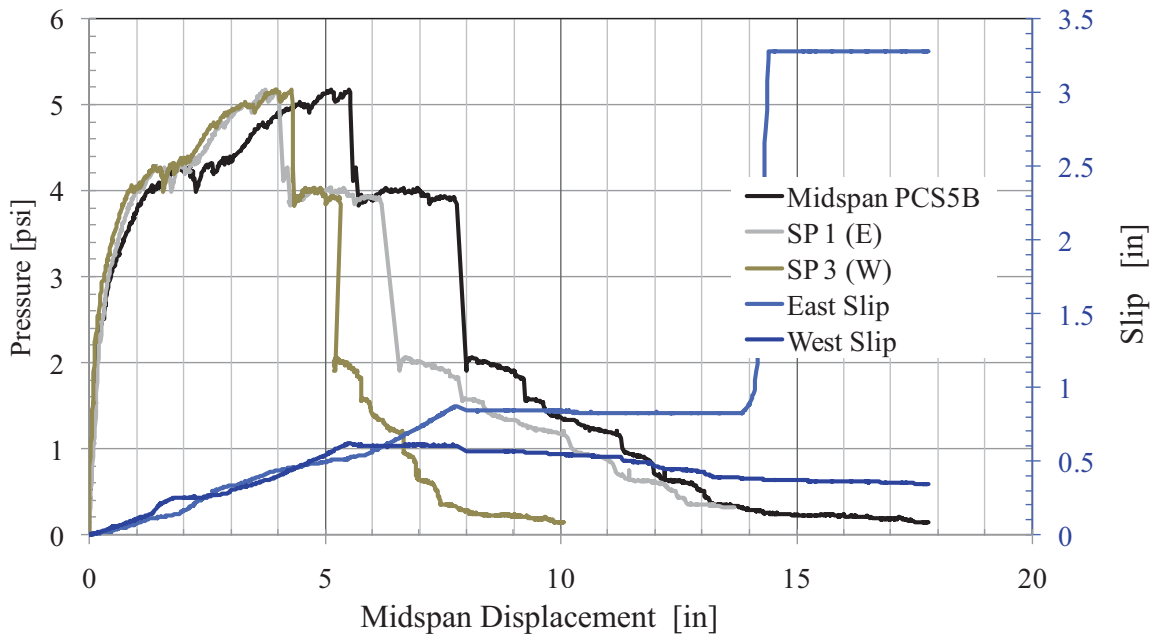

Figure 98. PCS5-B Response

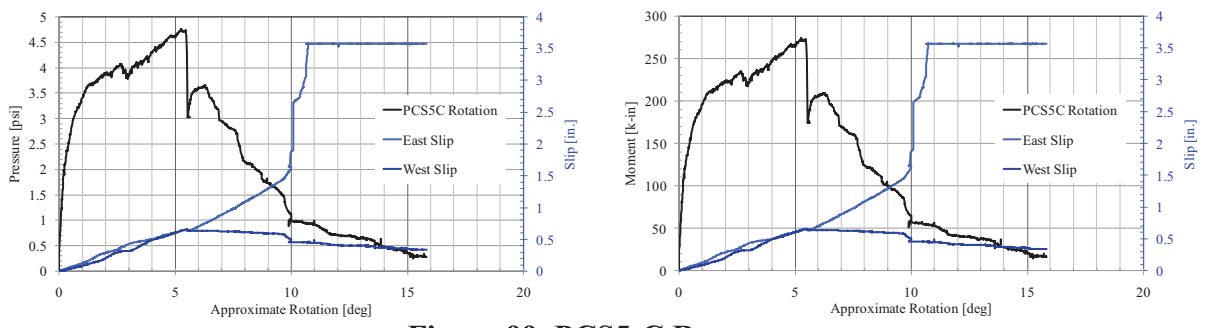
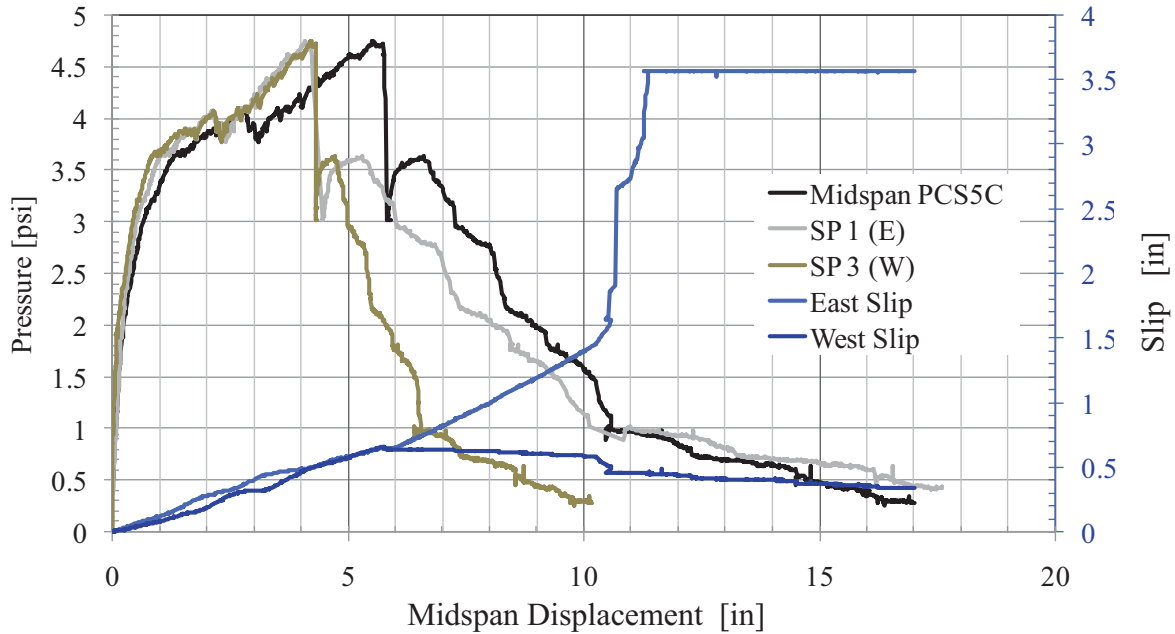

Figure 99. PCS5-C Response



Figure 100. PCS5 Panel Response (A, B, C)

6.9. PCS6 3-3-3 Specimen Performance

PCS6 consists of a partially composite 3-3-3 PC CSW panel fabricated with XPS insulation and carbon fiber C-Grid® shear ties. The panel is PS with WWR transverse reinforcement in both the interior and exterior wythe. The panel cross-section and reinforcement details are illustrated in Figure 101 and Figure 102.

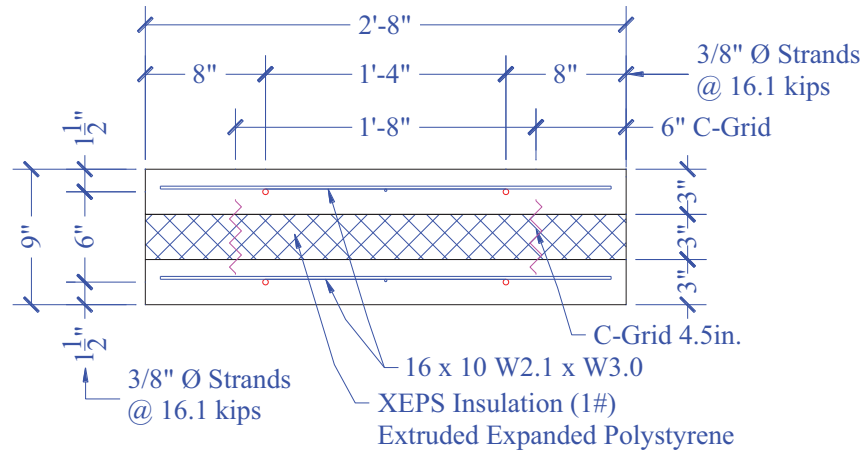

Figure 101. PCS6 Cross-Section Detail

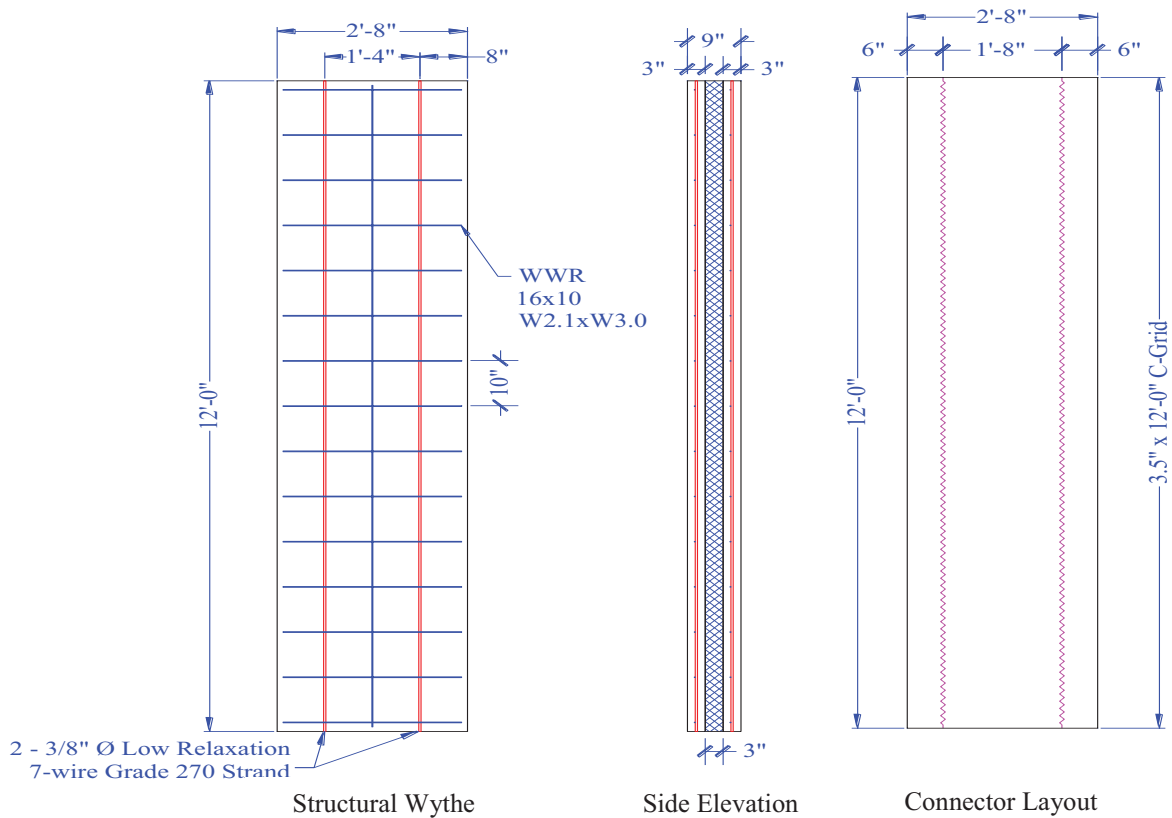

Figure 102. PCS6 Panel Detail

The measured response is summarized in Table 25. The midspan pressure displacement and moment-support rotation for the three specimen are in Figure 103 and Figure 104. The individual response of each panel and the end slip and quarter point displacements are included in Figure 105-107. Figure 108 shows a picture representation of the samples post-test.

Table 25. PCS6 Measured Response

Specimen	Age at Test [days]	Max Load [lbs]	Max Pressure [psi]	Corresponding Displacement [in]	East Slip [in]	West Slip [i.]	Rot. [deg]	Measured Moment Capacity [k-in]
PCS6-A	37	18581	4.839	3.644	0.502	0.504	3.475	278.71
PCS6-B	45	18146	4.726	2.945	0.443	0.236	2.810	272.19
PCS6-C	45	13233	3.446	2.061	0.021	0.413	1.968	198.50
Average		16653	4.34	2.88	0.32	0.38	2.75	249.8

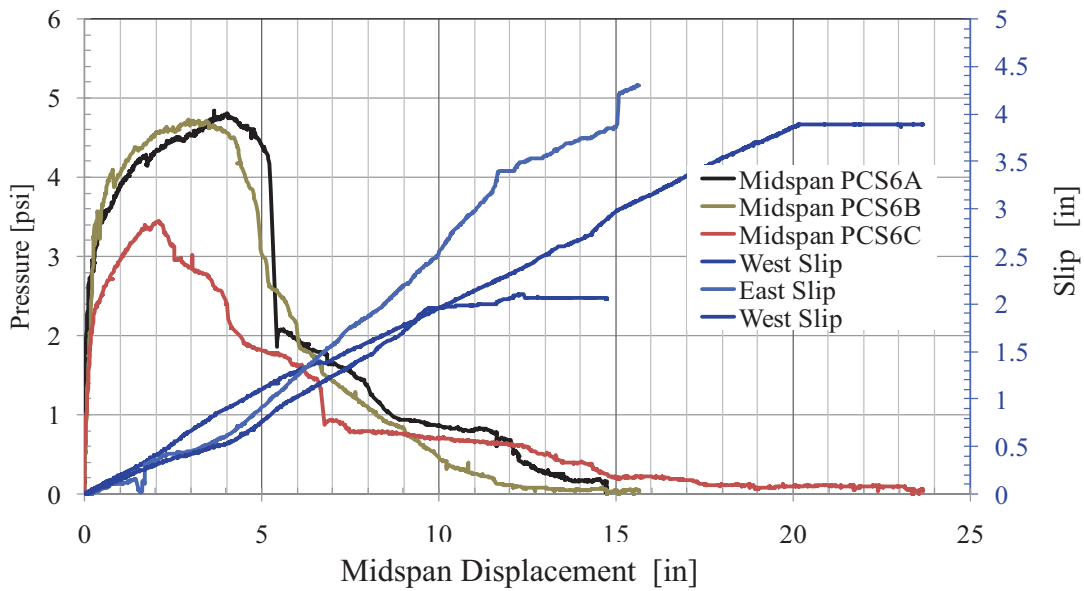

Figure 103. PCS6 Pressure–Displacement Response

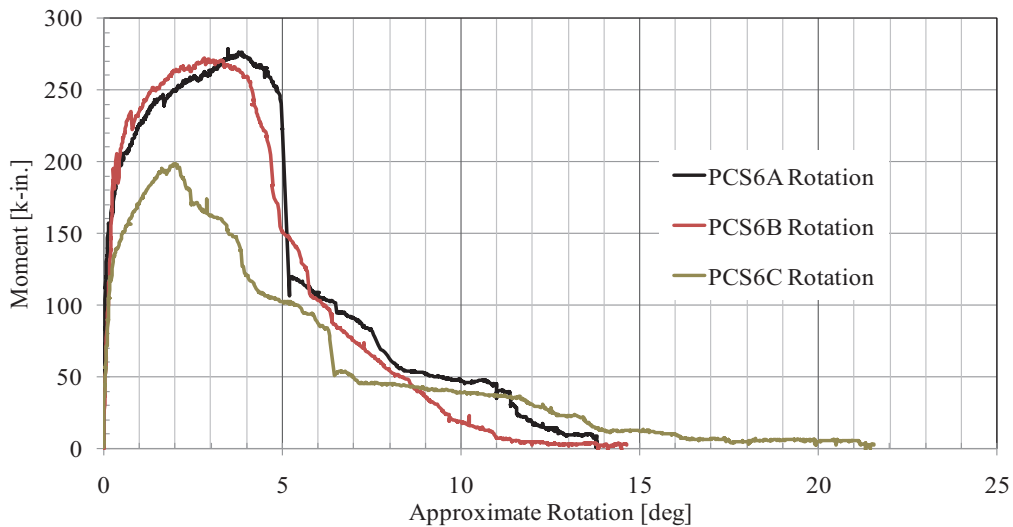

Figure 104. PCS6 Moment–Rotation Response

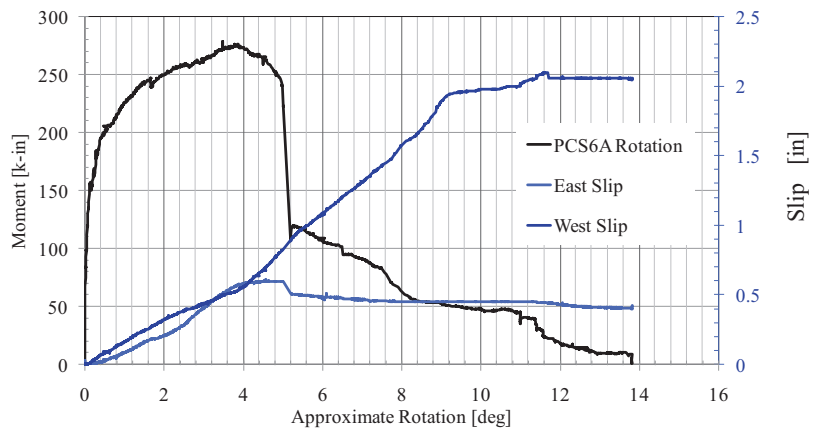
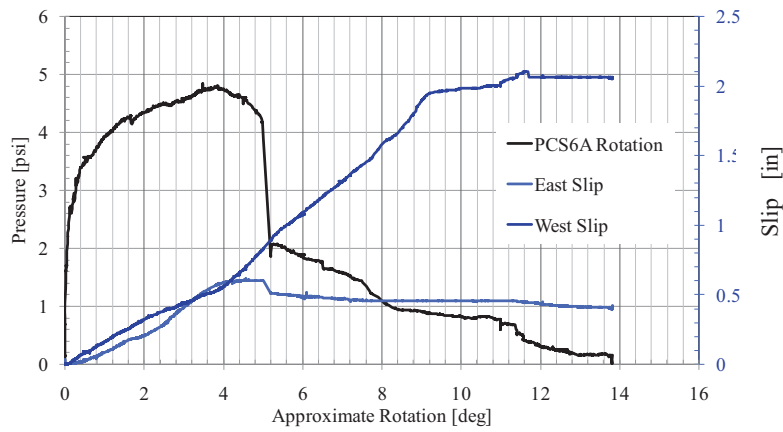
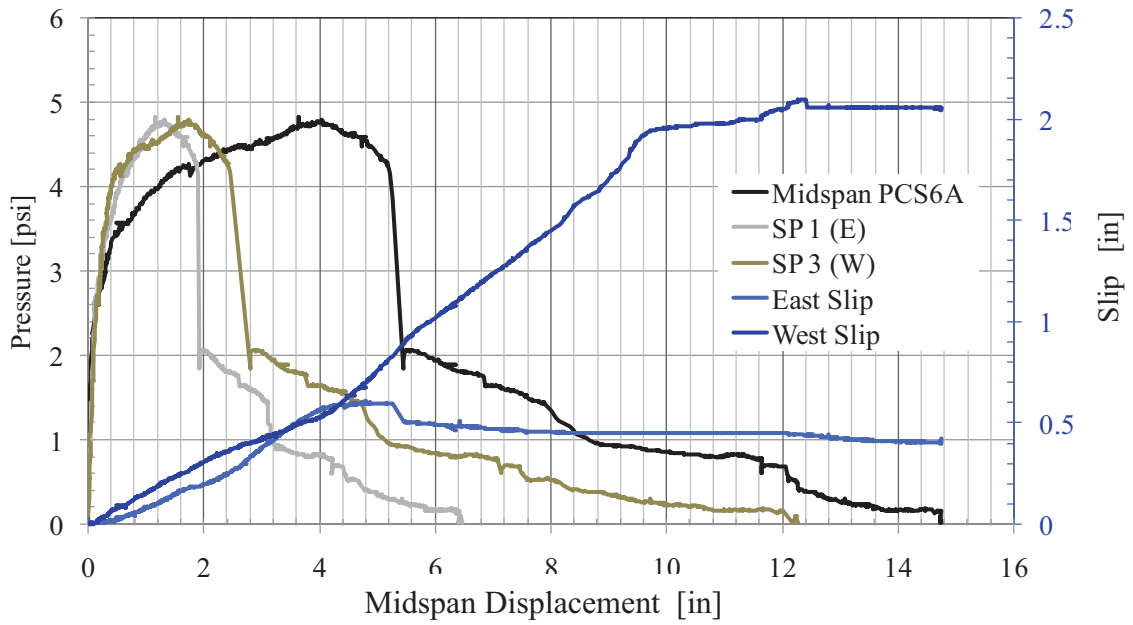

Figure 105. PCS6-A Response

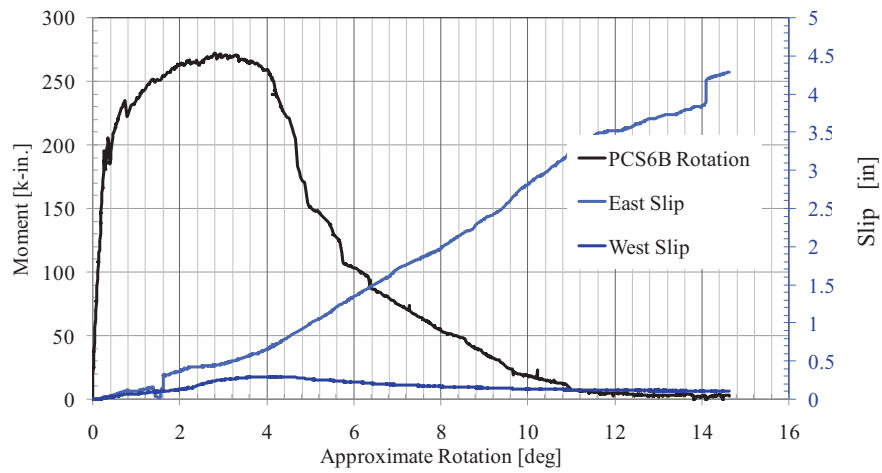
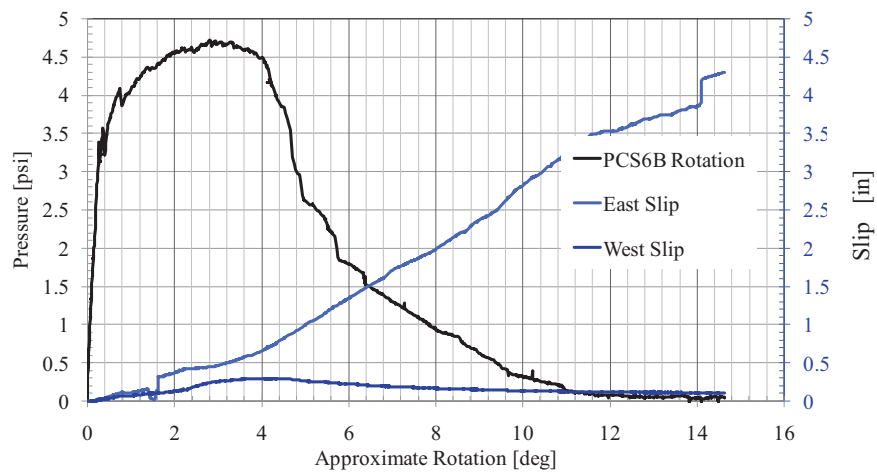
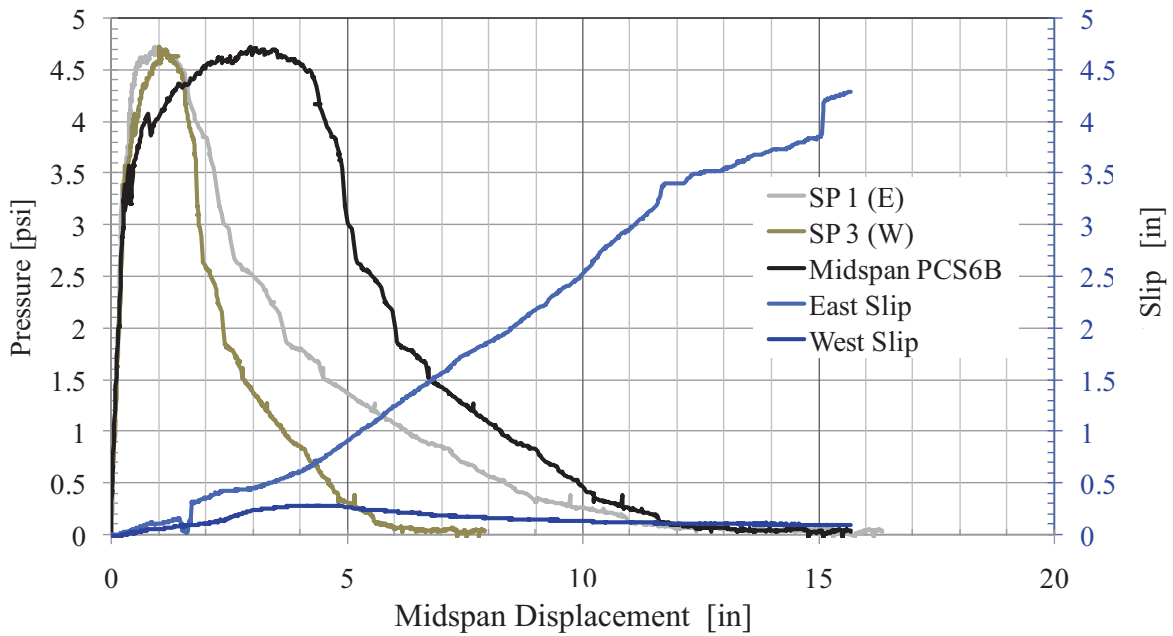

Figure 106. PCS6-B Response

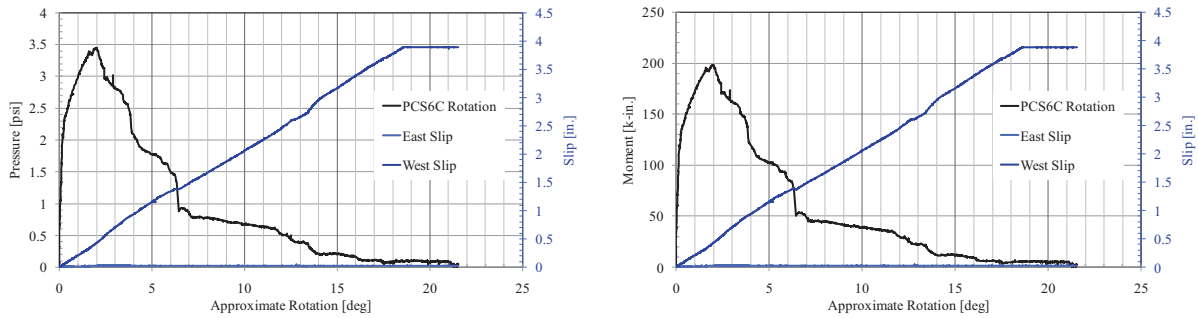
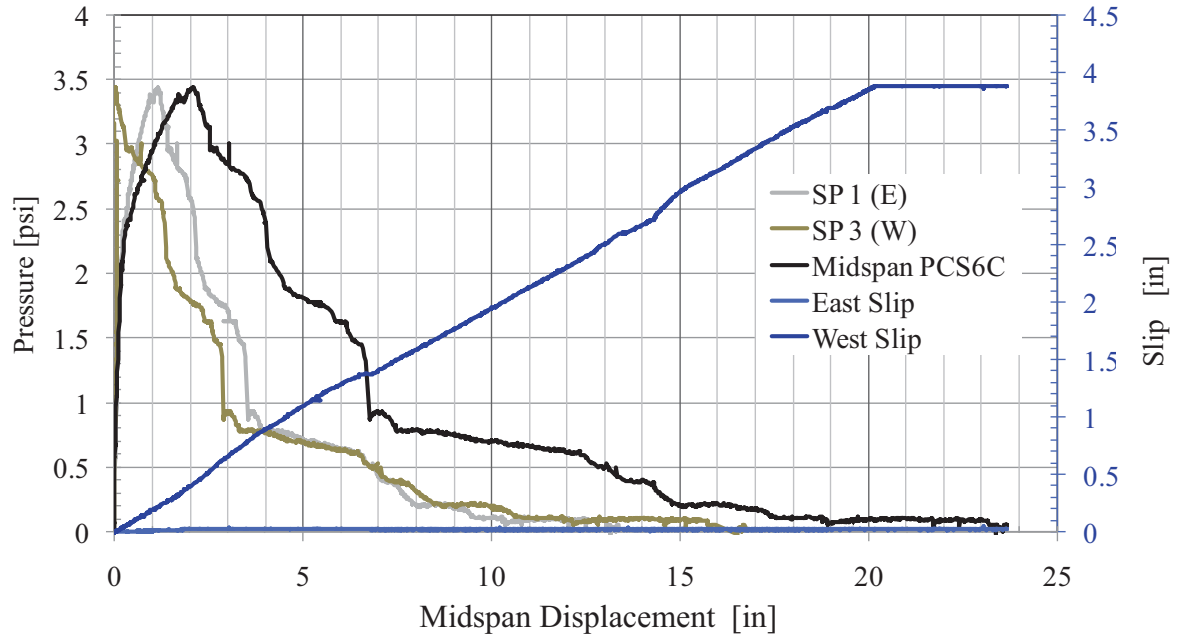

Figure 107. PCS6-C Response

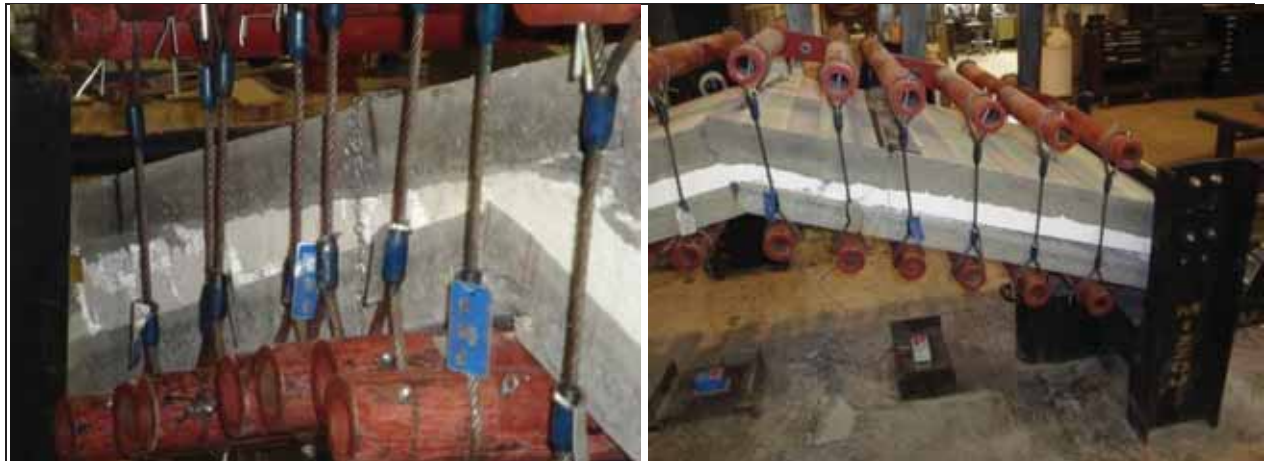

Figure 108. PCS6 Panel Response (A, B)

6.10. PCS7 3-3-3 Specimen Performance

PCS7 consists of a partially composite 3-3-3 PC CSW panel fabricated with XPS insulation and glass fiber THERMOMASS® composite shear pins. The panel is conventionally reinforced with non-PS longitudinal bars and #3 transverse reinforcement in both the interior and exterior wythe. The panel cross-section and reinforcement details are illustrated in Figure 109 and Figure 110.

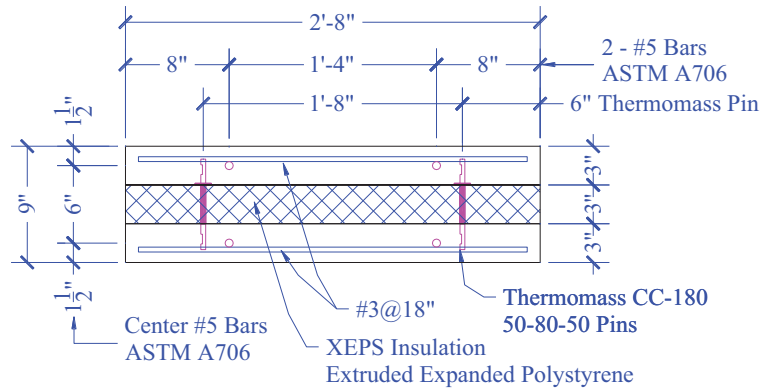

Figure 109. PCS7 Cross-Section Detail

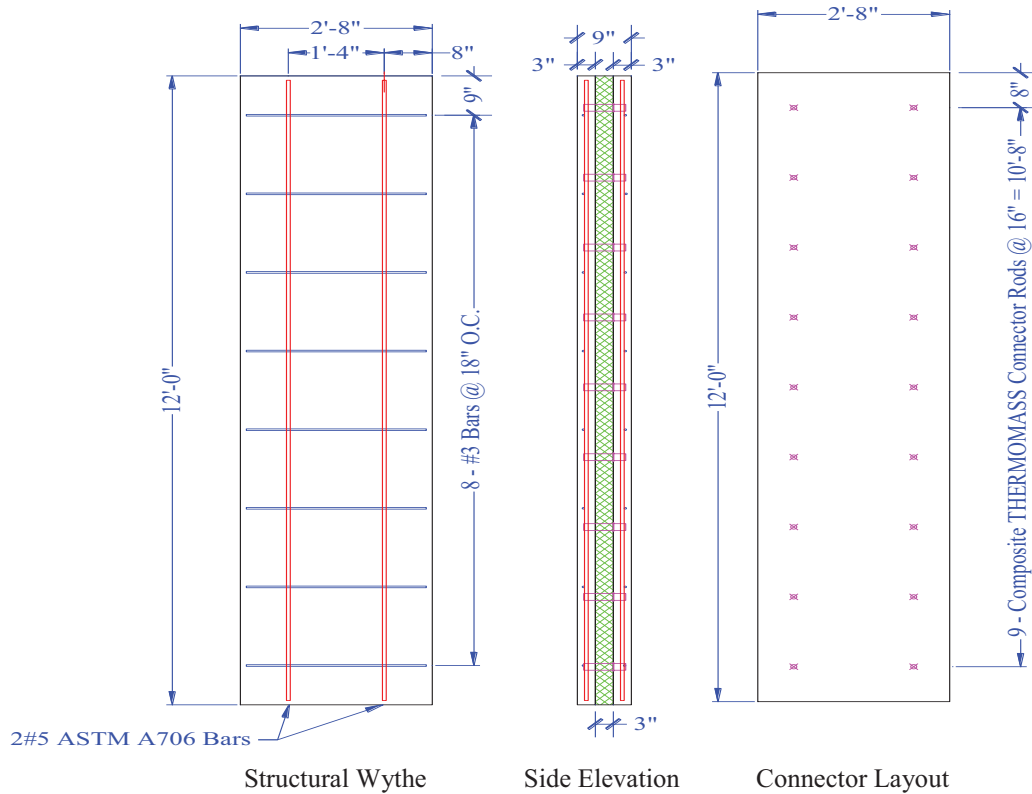

Figure 110. PCS7 Panel Detail

The measured response is summarized in Table 26. The midspan pressure displacement and moment-support rotation for the three specimen are in Figure 111 and Figure 112. The individual response of each panel and the end slip and quarter point displacements are included in Figure 113-115. Figure 116 shows a picture representation of the samples post-test.

Table 26. PCS7 Measured Response

Specimen	Age at Test [days]	Max Load [lbs]	Max Pressure [psi]	Corresponding Displacement [in]	East Slip [in]	West Slip [in]	Rot. [deg]	Measured Moment Capacity [k-in]
PCS7-A	106	18661	4.860	7.434	0.847	0.809	7.063	279.91
PCS7-B	106	19484	5.074	6.744	0.615	0.905	6.413	292.26
PCS7-C	94	15561	4.0524	4.4584	0.2757	0.7599	4.2497	233.42
Average		17902	4.66	6.21	0.58	0.82	5.91	268.5

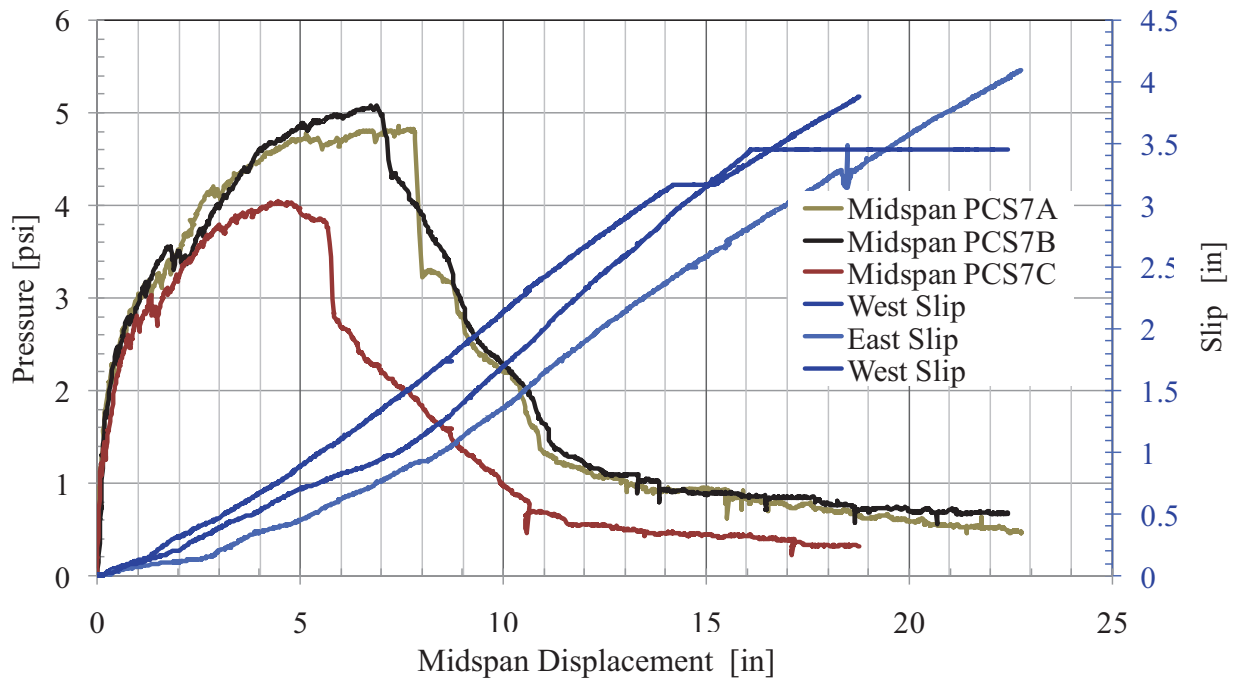

Figure 111. PCS7 Pressure–Displacement Response

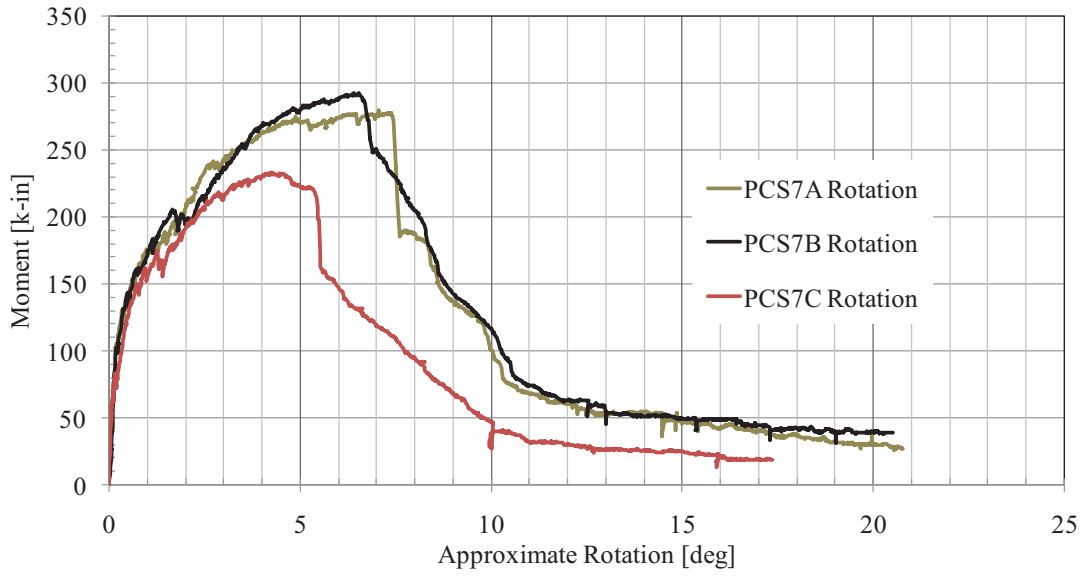

Figure 112. PCS7 Moment-Rotation Response

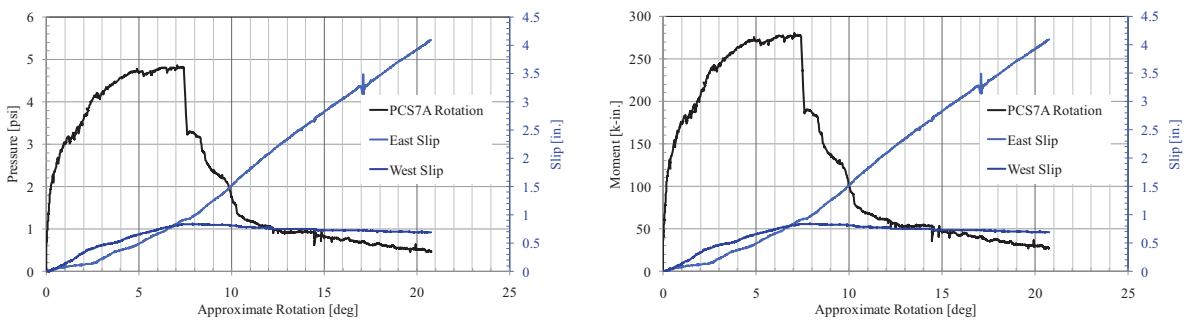
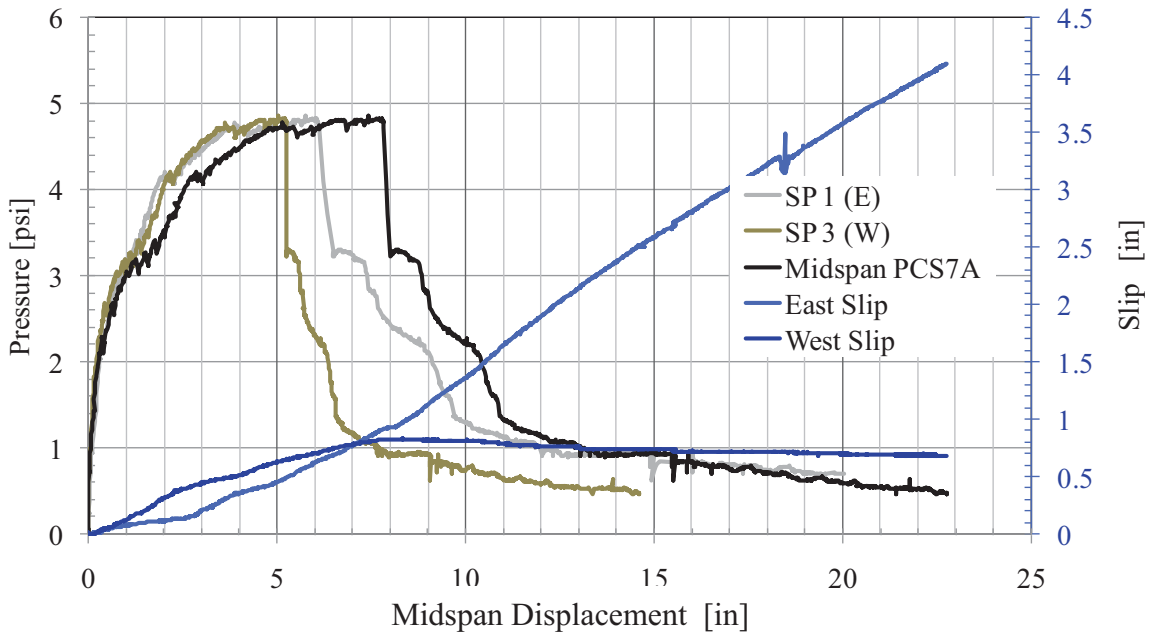

Figure 113. PCS7-A Response

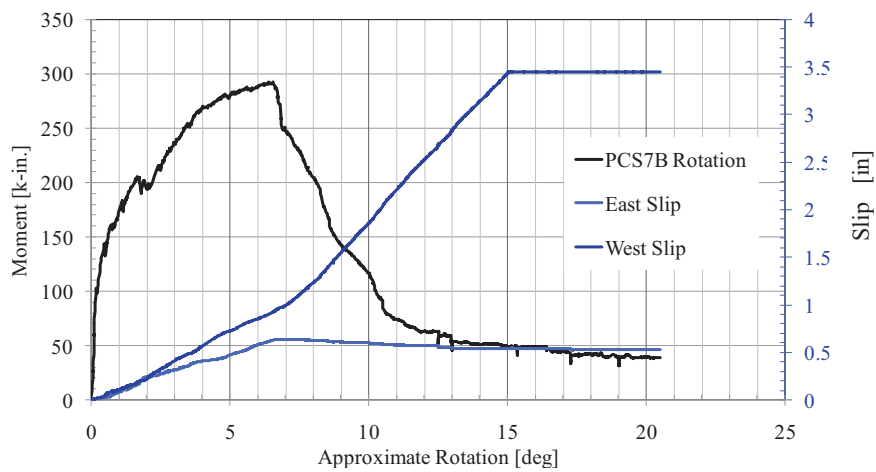
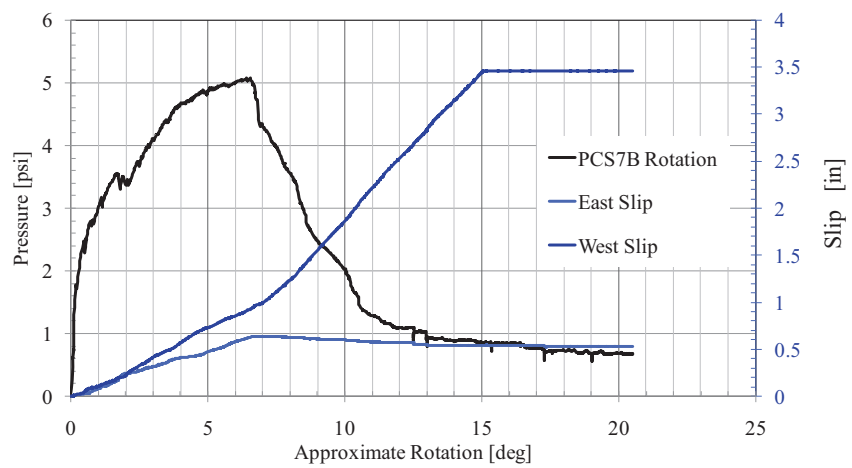
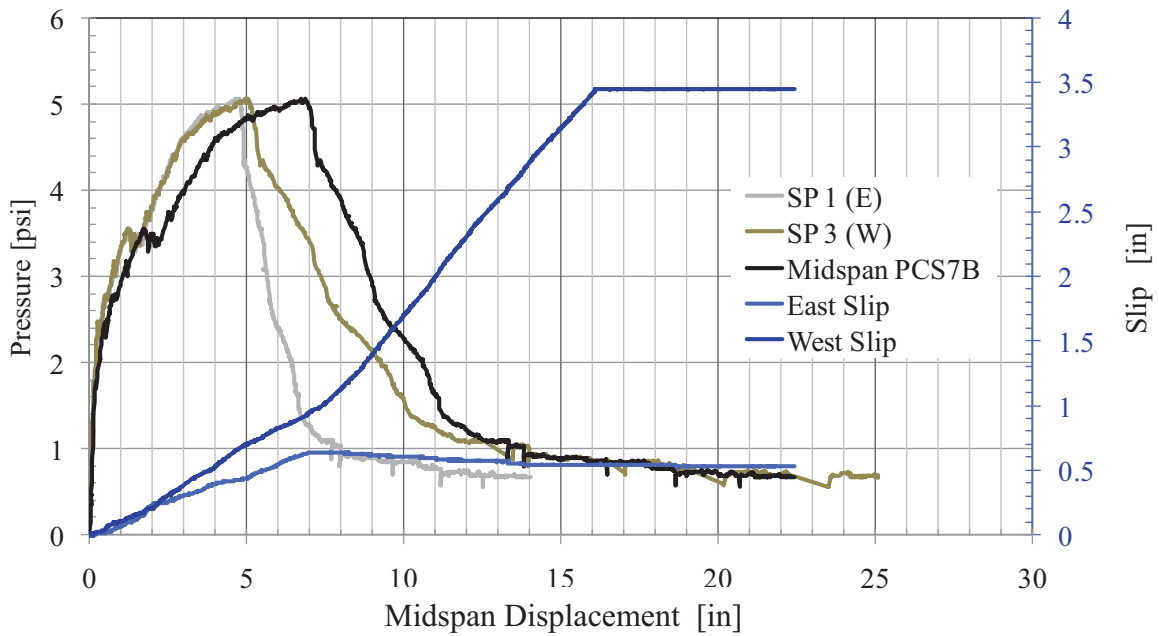

Figure 114. PCS7-B Response

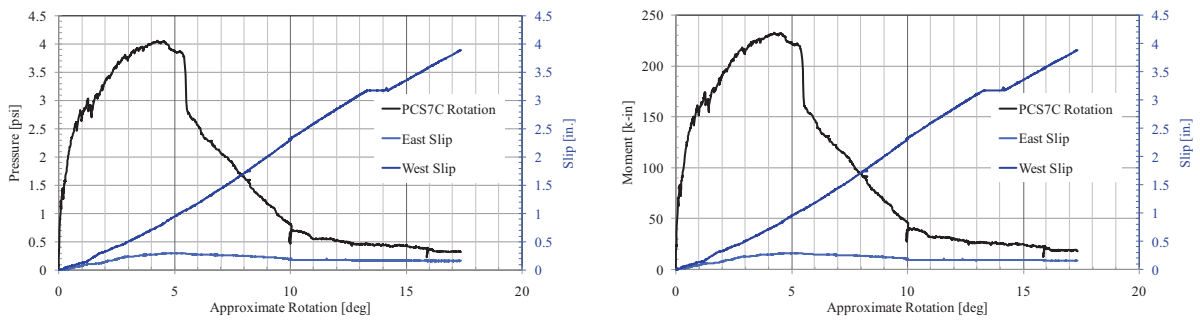
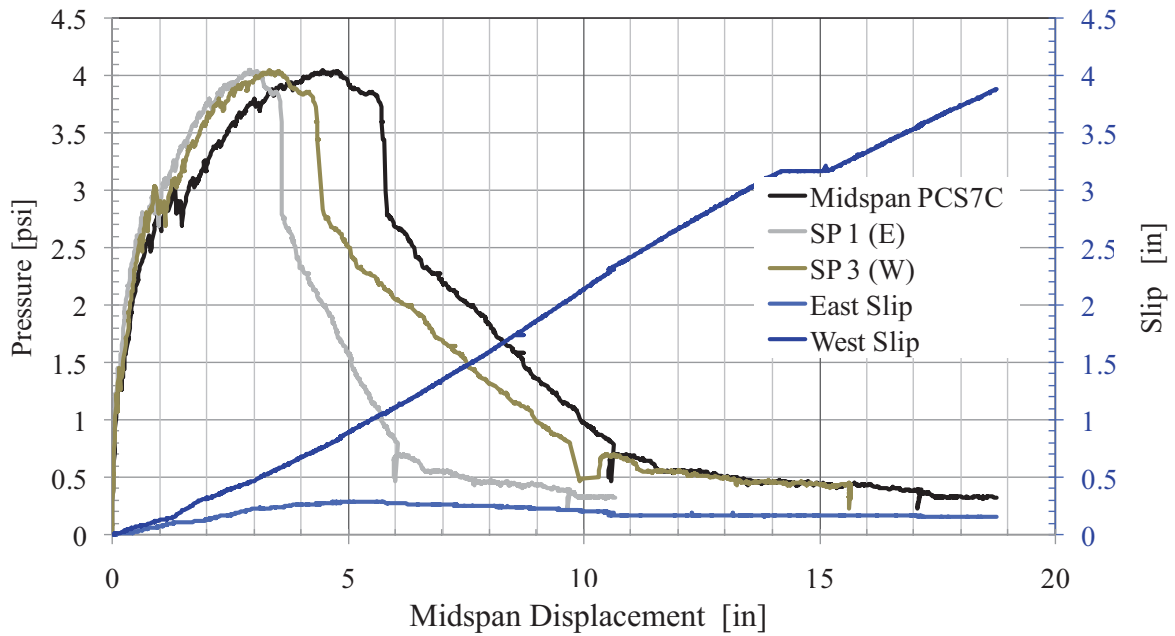

Figure 115. PCS7-C Response



Figure 116. PCS7 Panel Response (A, B, C)

6.11. PCS8 3-3-3 Specimen Performance

PCS8 consists of a partially composite 3-3-3 PC CSW panel fabricated with PIMA insulation and glass fiber THERMOMASS® composite shear pins. The panel is PS with rebar transverse reinforcement in both the interior and exterior wythe. The panel cross-section and reinforcement details are illustrated in Figure 117 and Figure 118.

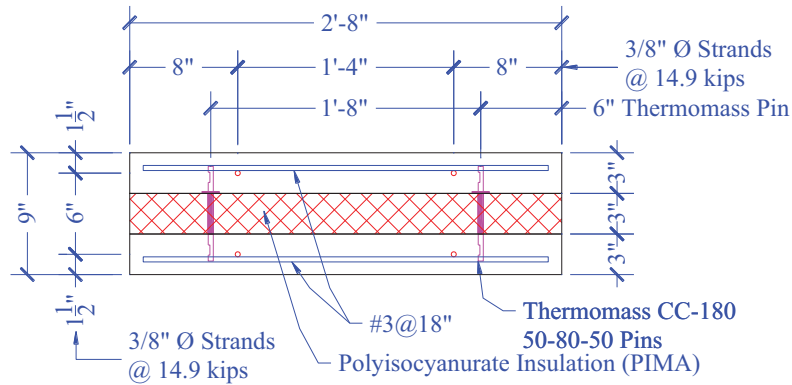

Figure 117. PCS8 Cross-Section Detail

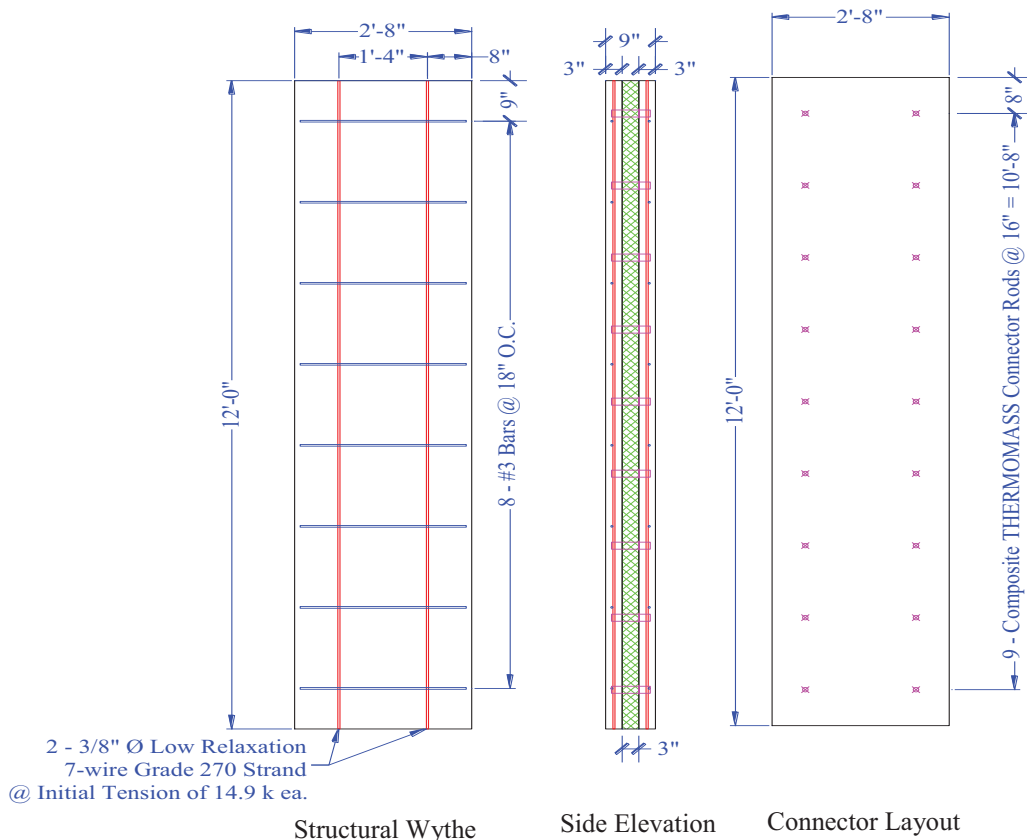

Figure 118. PCS8 Panel Detail

The measured response is summarized in Table 27. The midspan pressure displacement and moment–support rotation for the three specimens are in Figure 119 and Figure 120. The individual response of each panel and the end slip and quarter point displacements are included in Figure 121-123. Figure 124 shows a picture representation of the samples post-test.

Note: Due to a control problem during testing, PCS8-B was loaded very rapidly. The data acquisition was on; however, due to the slow acquisition rate only three data points were recorded. The data thus appear to be tri-linear. This is a consequence of the aforementioned testing issues and not variability in the panel performance.

Table 27. PCS8 Measured Response

Specimen	Age at Test [days]	Max Load [lbs]	Max Pressure [psi]	Corresponding Displacement [in]	East Slip [in]	West Slip [in]	Rot. [deg]	Measured Moment Capacity [k-in]
PCS8-A	101	15051	3.9195	4.3814	0.6930	0.3873	4.1765	225.76
PCS8-B	108	14369	3.7420	2.6614	0.5794	0.2102	2.5398	215.54
PCS8-C	108	16901	4.4013	5.2511	0.6607	0.5929	5.0017	253.51
Average		15440	4.02	4.10	0.64	0.40	3.91	231.6

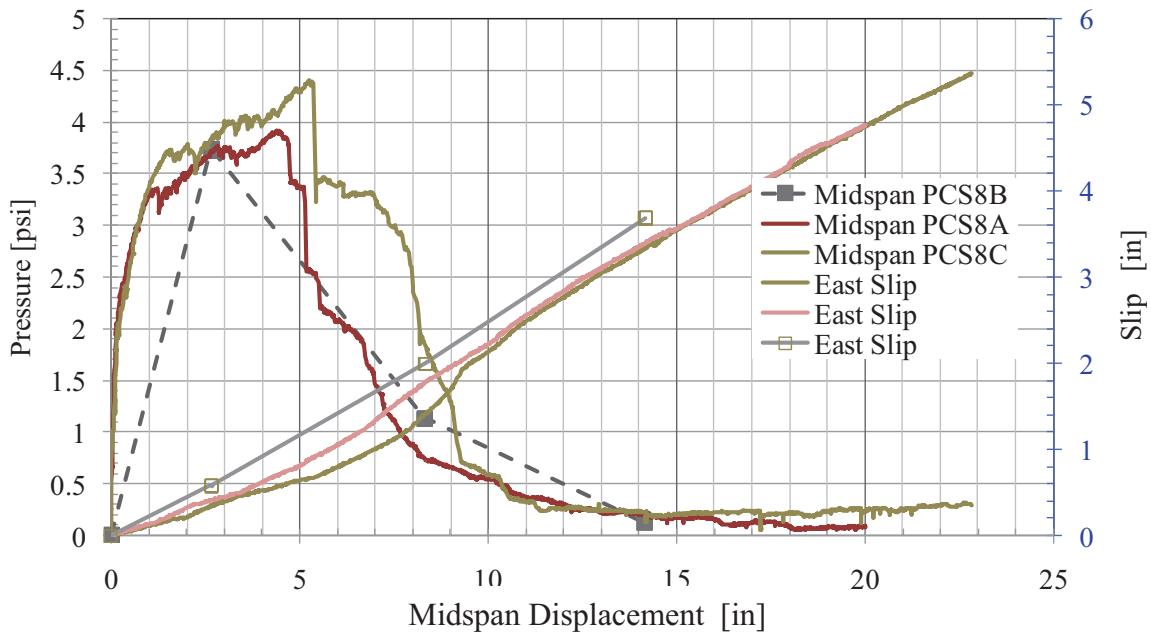

Figure 119. PCS8 Pressure–Displacement Response

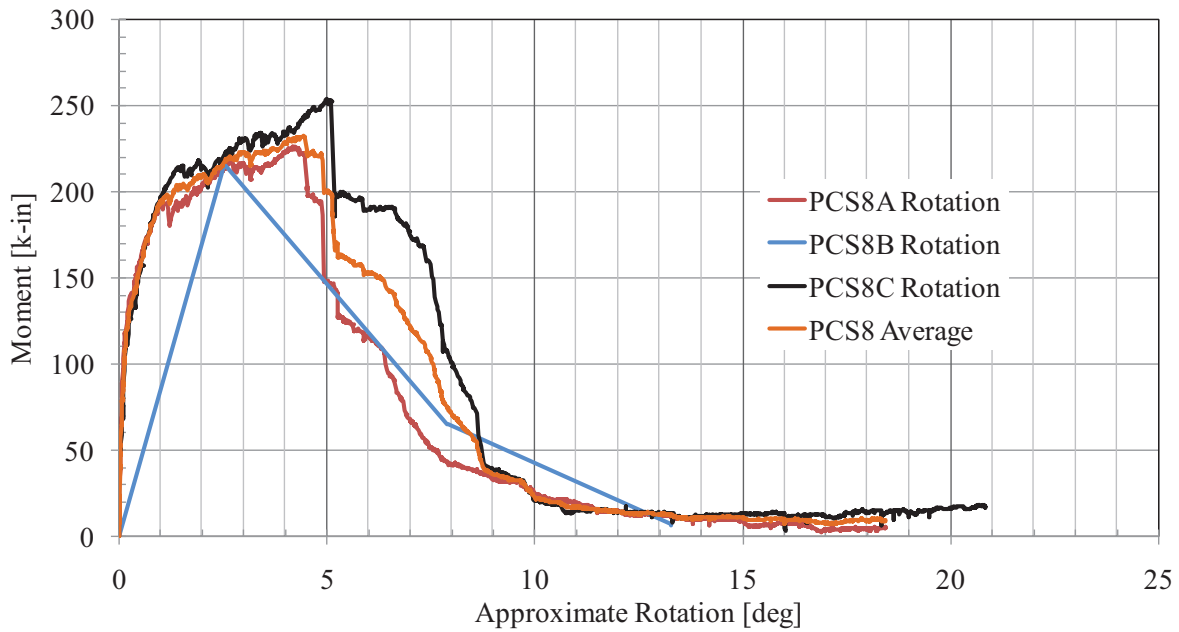

Figure 120. PCS8 Moment-Rotation Response

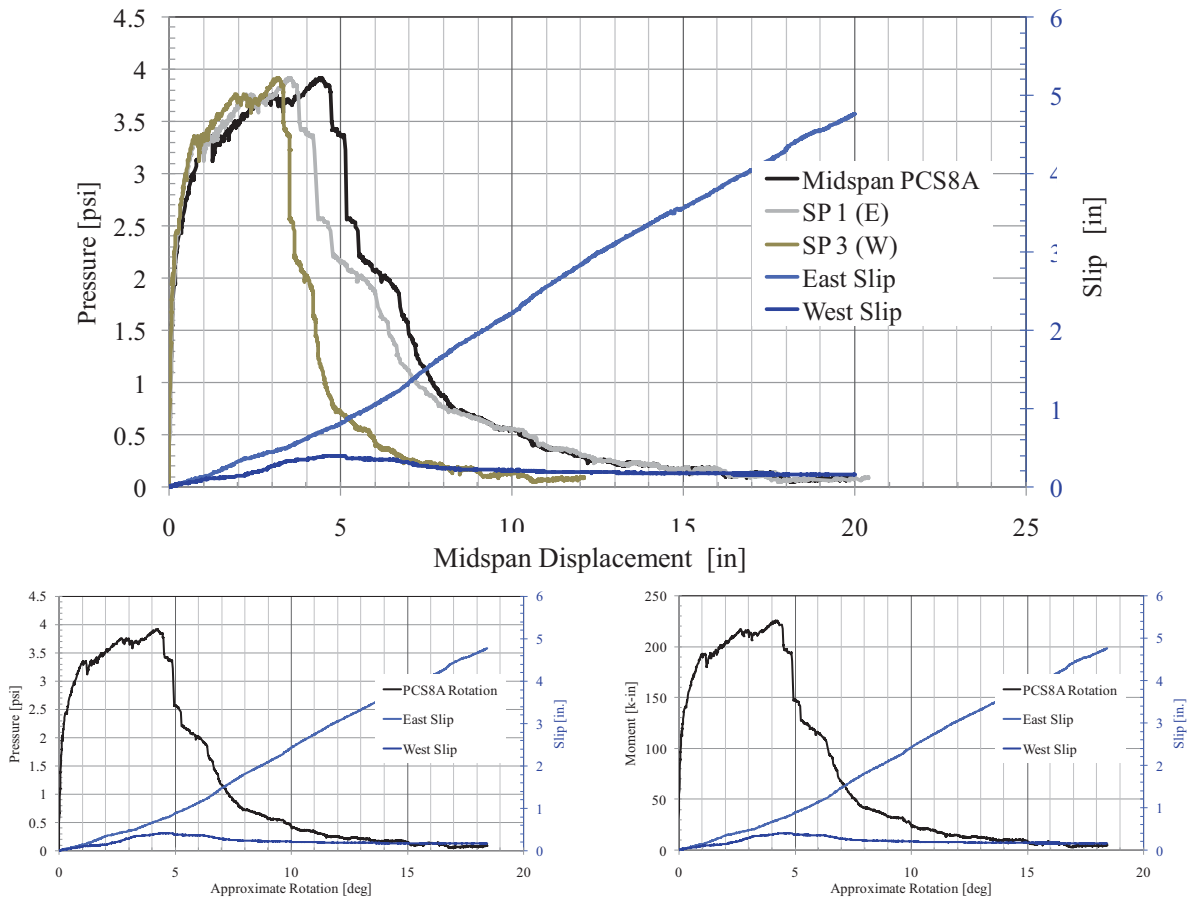

Figure 121. PCS8-A Response

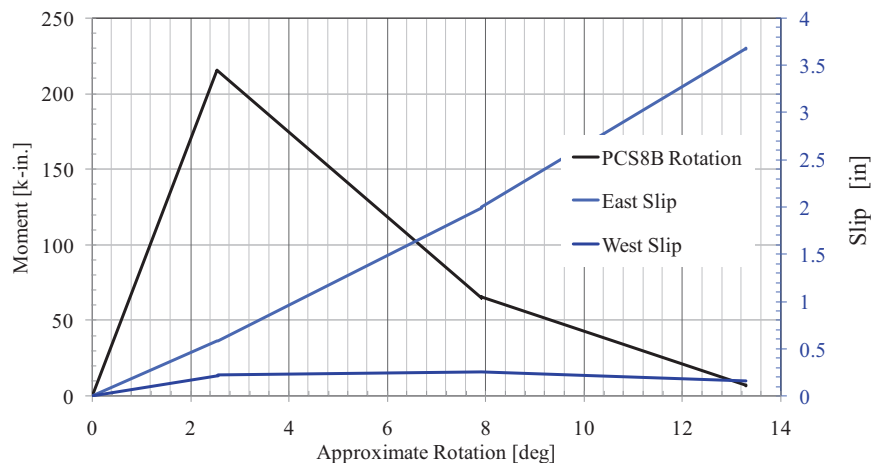
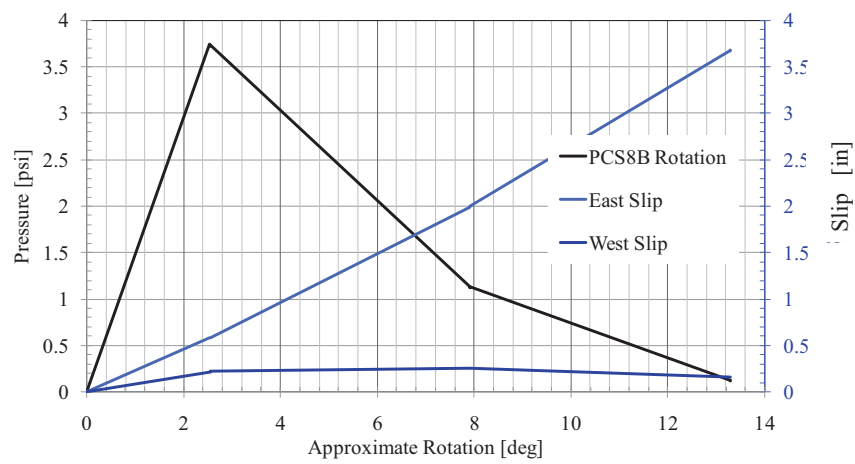
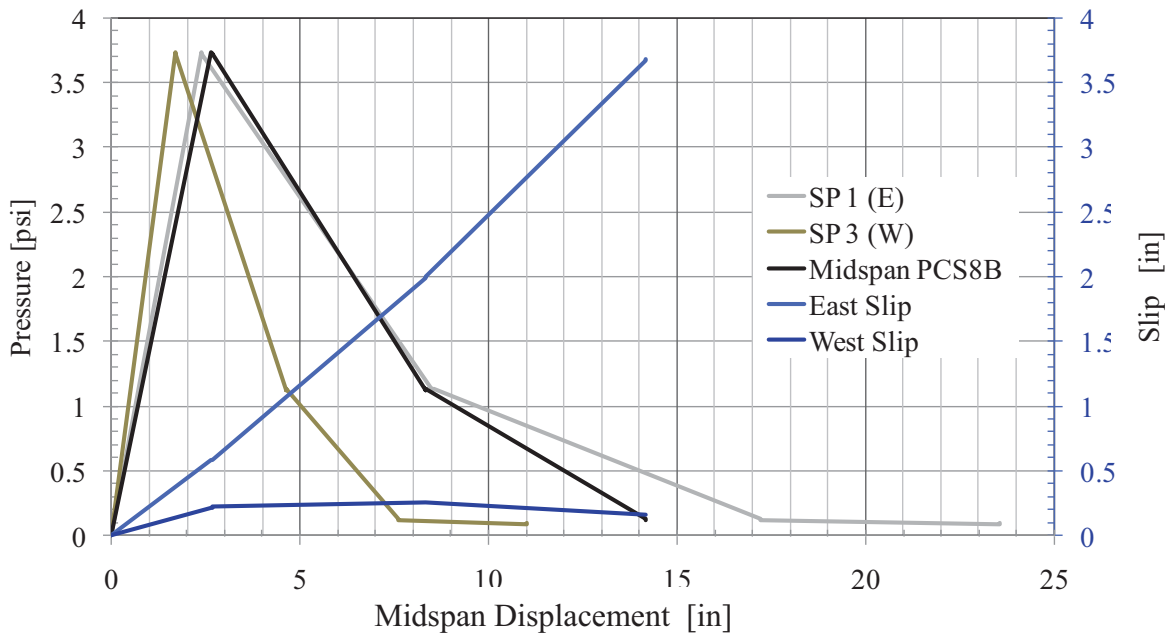

Figure 122. PCS8-B Response

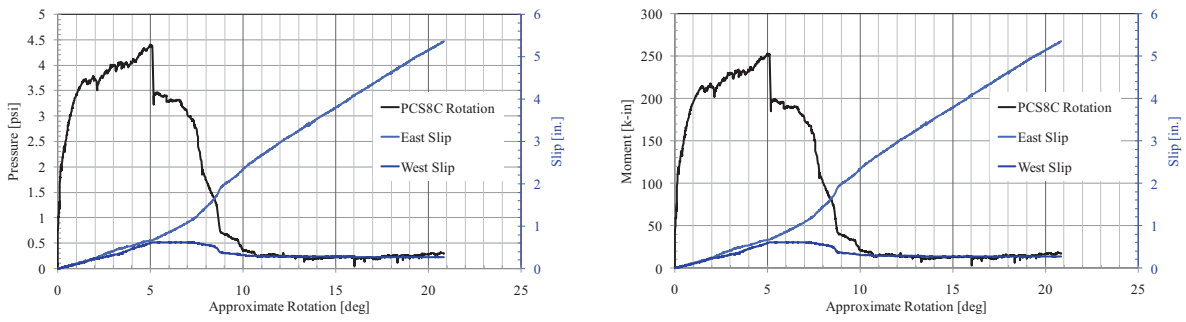
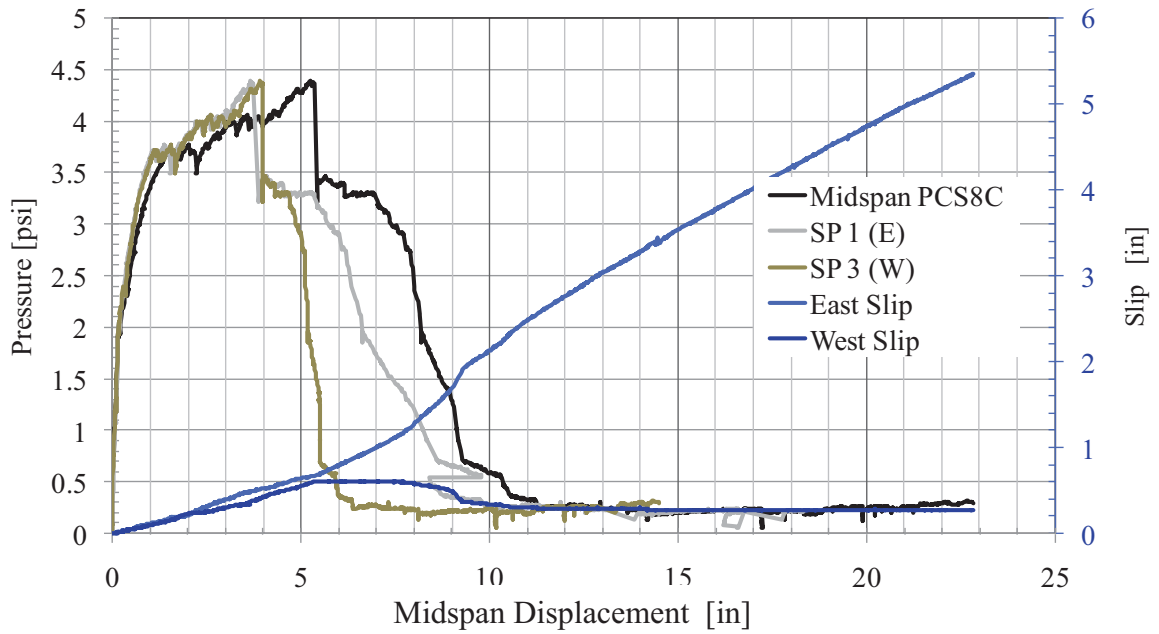

Figure 123. PCS8-C Response



Figure 124. PCS8 Panel Response (A and C)

6.12. PCS9 3-3-3 Specimen Performance

PCS9 consists of a partially composite 3-3-3 PC CSW panel fabricated with PIMA insulation and carbon fiber C-Grid® shear pins. The panel is prestressed with WWR transverse reinforcement in both the interior and exterior wythe. The panel cross-section and reinforcement details are illustrated in Figure 125 and Figure 126.

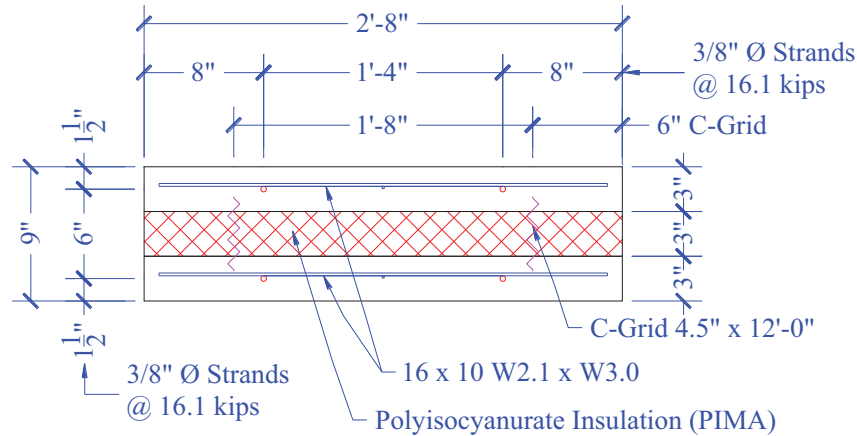

Figure 125. PCS9 Cross-Section Detail

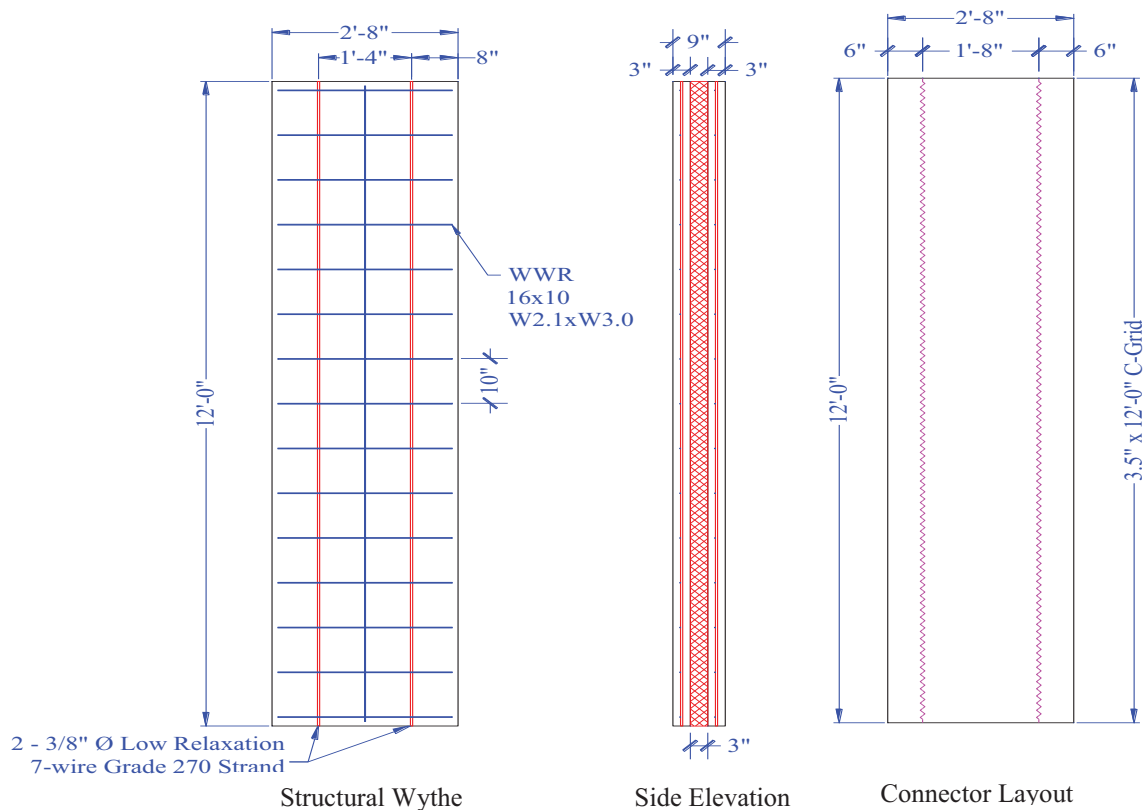

Figure 126. PCS9 Panel Detail

The measured response is summarized in Table 28. The midspan pressure displacement and moment–support rotation for the three specimen are in Figure 127 and Figure 128. The individual response of each panel and the end slip and quarter point displacements are included in Figure 129-131. Figure 132 shows a picture representation of the samples post-test.

Table 28. PCS9 Measured Response

Specimen	Age at Test [days]	Max Load [lbs]	Max Pressure [psi]	Corresponding Displacement [in]	East Slip [in]	West Slip [in]	Rot. [deg]	Measured Moment Capacity [k-in]
PCS9-A	37	21311	5.550	1.809	0.190	0.180	1.727	319.67
PCS9-B	41	20804	5.418	1.882	0.235	0.133	1.797	312.06
PCS9-C	41	22455	5.848	2.573	0.152	0.356	2.456	336.82
Average		21524	5.61	2.09	0.19	0.22	1.99	322.9

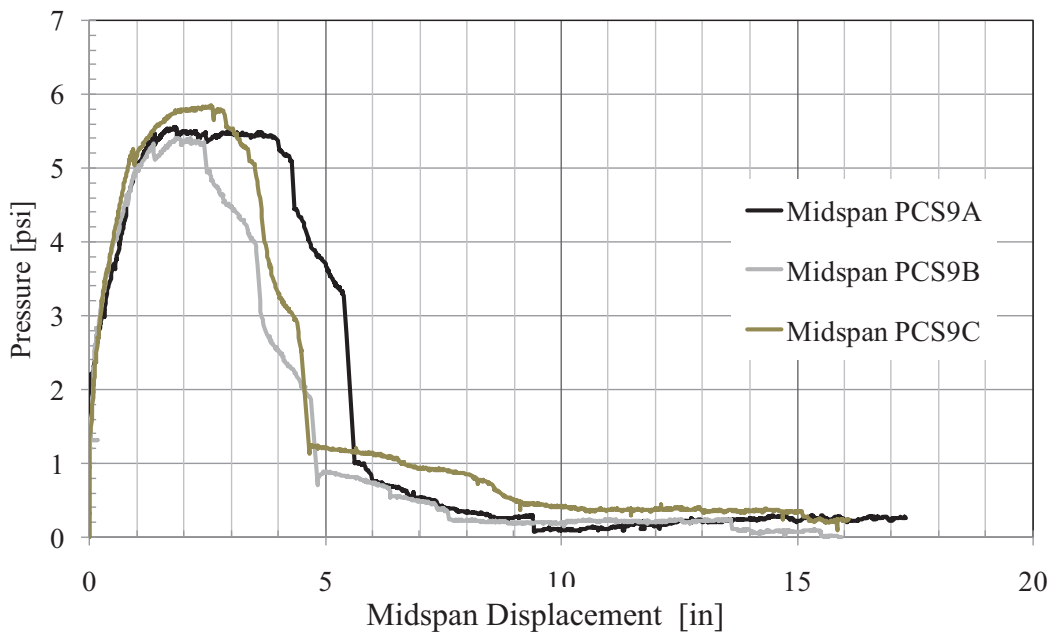

Figure 127. PCS9 Pressure–Displacement Response

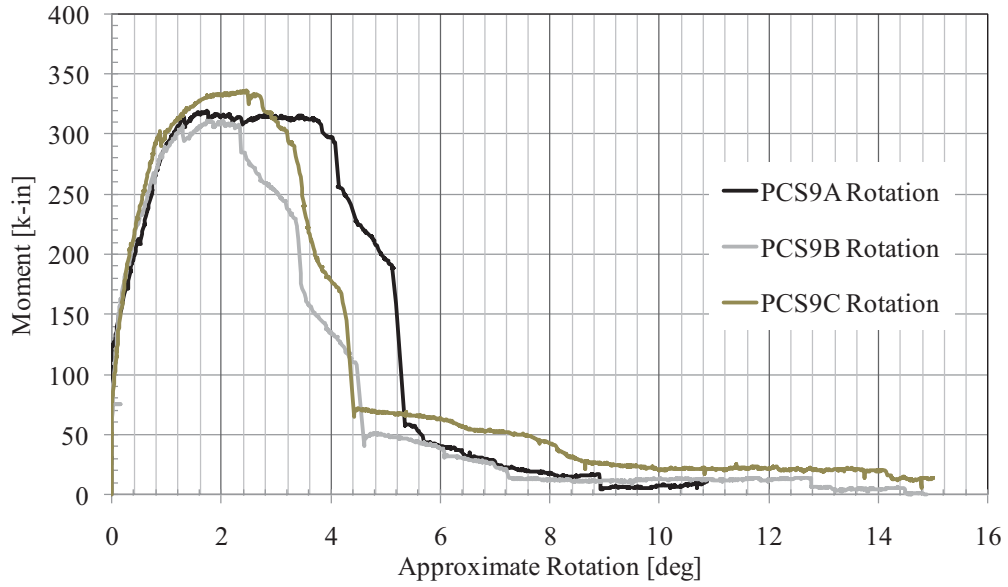

Figure 128. PCS9 Moment-Rotation Response

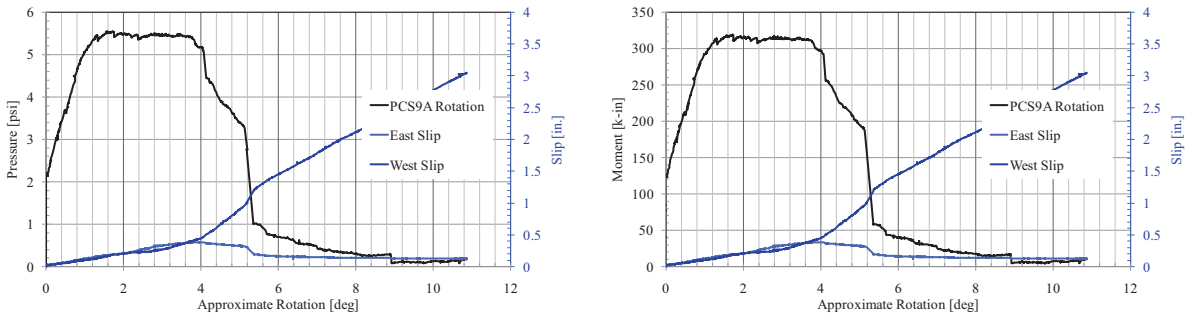
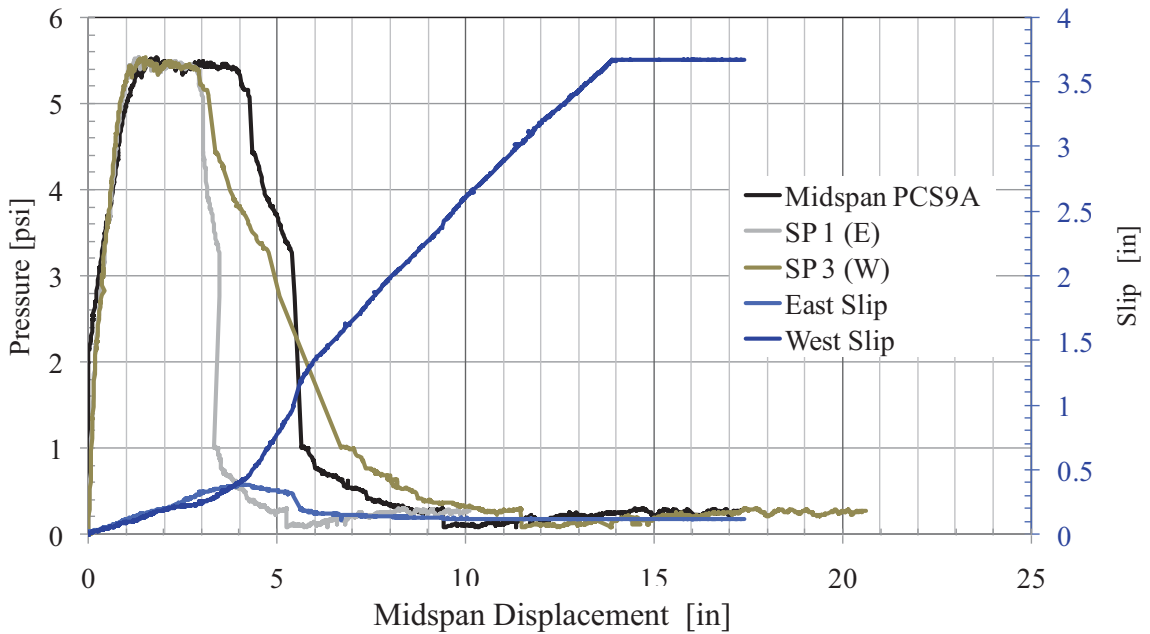

Figure 129. PCS9-A Response

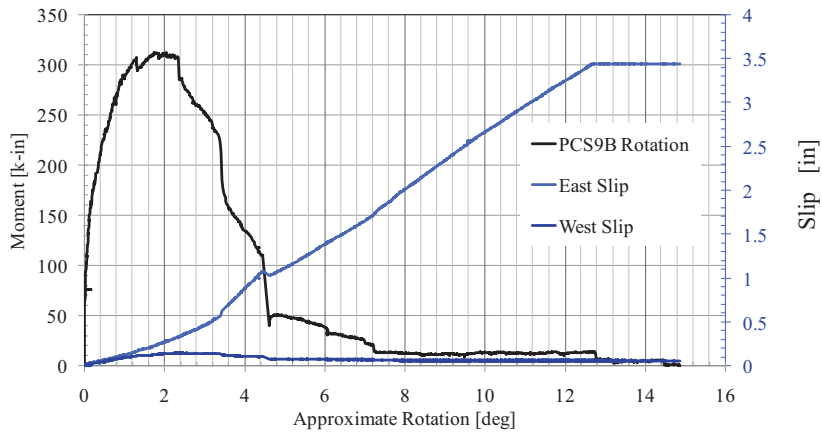
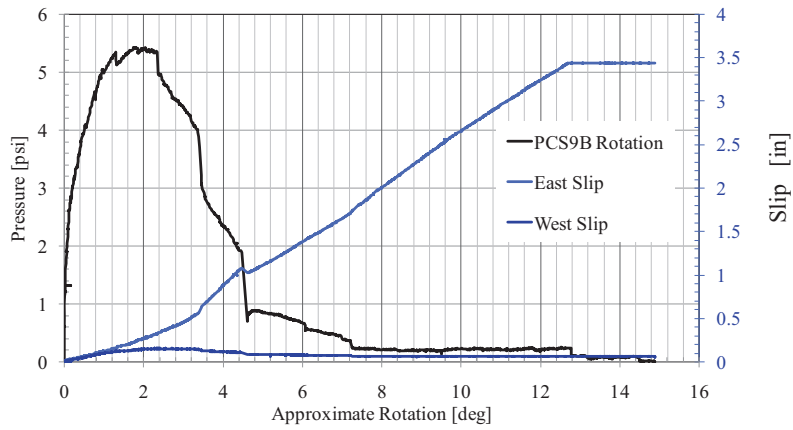
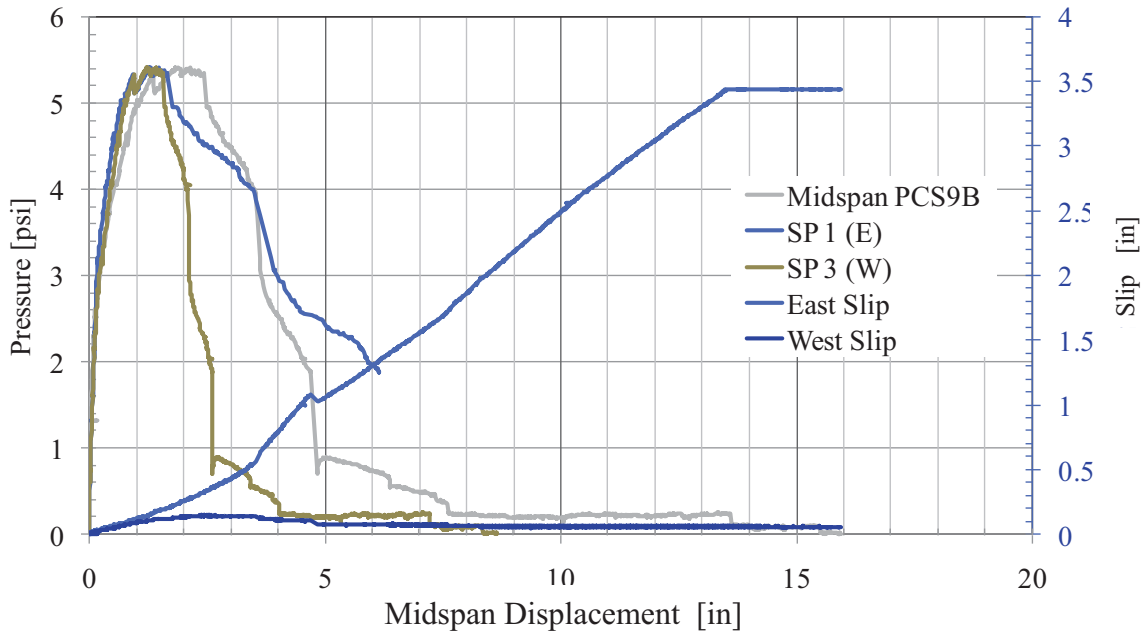

Figure 130. PCS9-B Response

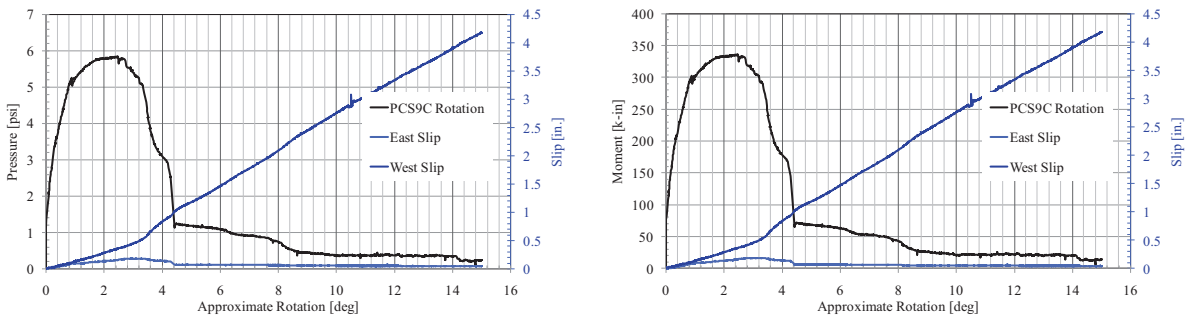
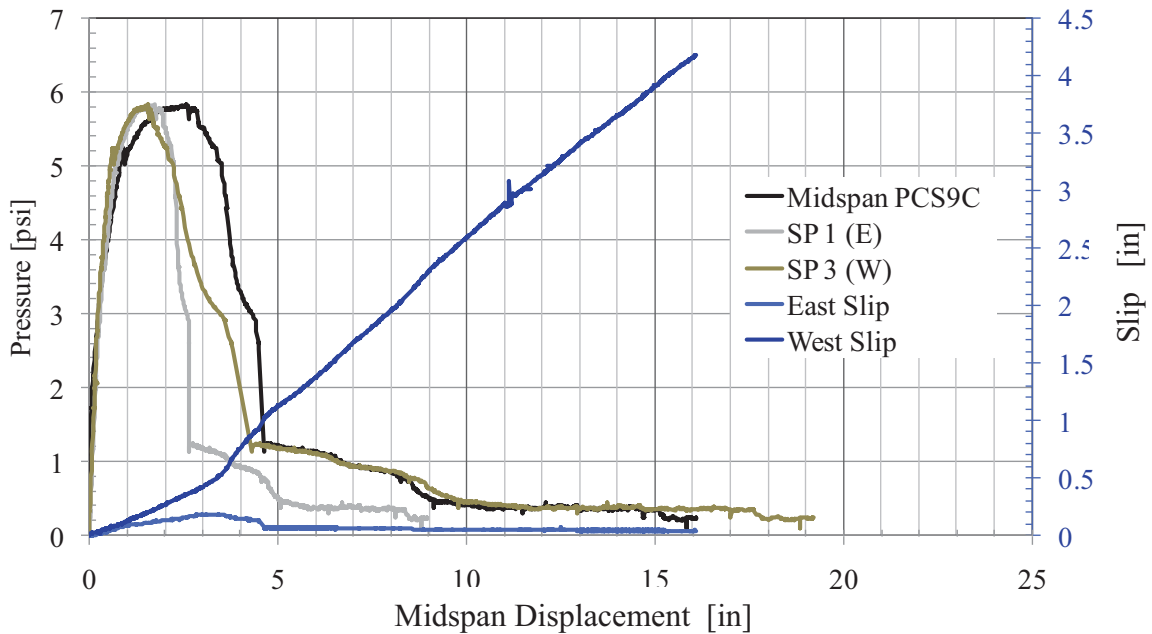

Figure 131. PCS9-C Response



Figure 132. PCS9 Panel Response (A, B, C)

6.13. Tyn1 3-4-3 Specimen Performance (Bonded Strand)

Tyn1 consists of a partially composite 3-4-3 PC CSW panel fabricated with XPS insulation and Meadow Burke steel truss girder shear ties. The panel is prestressed with conventional transverse reinforcement in both the interior and exterior wythe. The panel cross-section and reinforcement details are illustrated in Figure 133 and Figure 134.

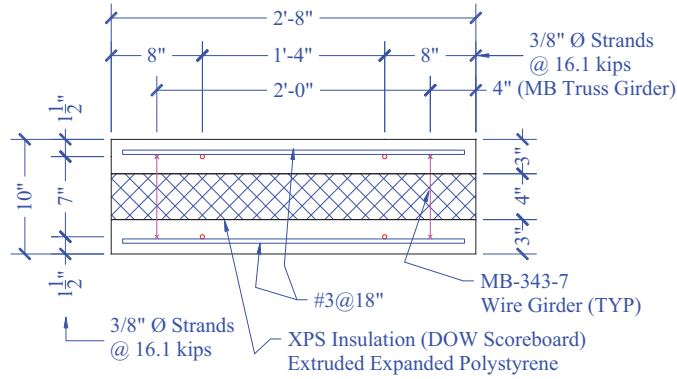

Figure 133. Tyn1 Cross-Section Detail

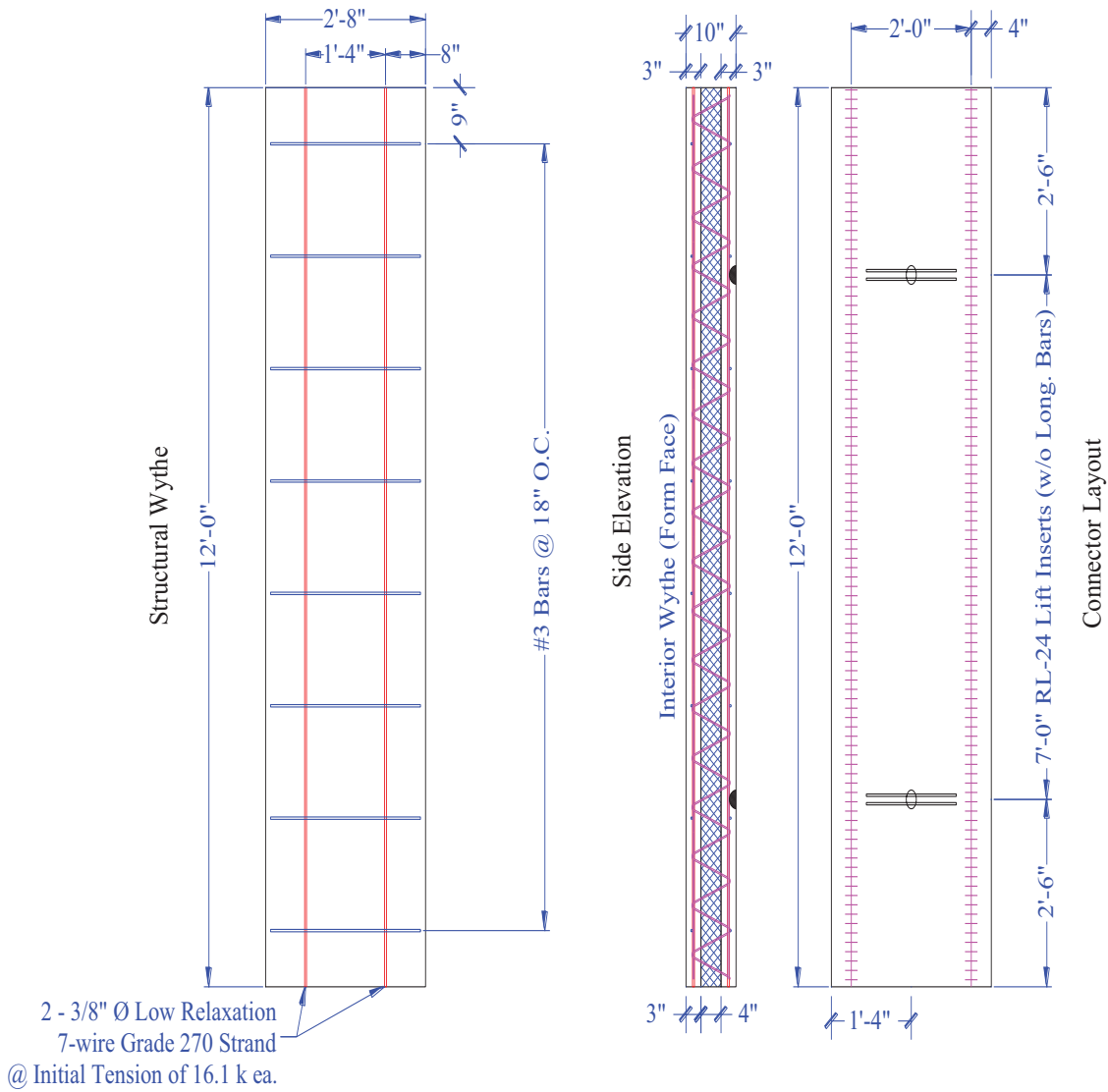

Figure 134. Tyn1 Panel Detail

The measured response is summarized in Table 29. The midspan pressure displacement for the three specimen are in Figure 135. The individual response of each panel and the quarter point displacements are included in Figure 136, Figure 137 and Figure 138.

Table 29. Tyn1 Measured Response

Specimen	Age at Test [days]	Max Load [lbs]	Max Pressure [psi]	Corresponding Displacement [in]	East Slip [in]	West Slip [in]	Rot. [deg]	Measured Moment Capacity [k-in]
Tyn1-A	95	21867	5.69	0.47	NA	NA	0.446	328.0
Tyn1-B	99	20331	5.29	0.58	NA	NA	0.553	305.0
Tyn1-C	204	20044	5.22	0.71	NA	NA	0.681	300.7
		20747	5.40	0.59	NA	NA	0.56	311.2

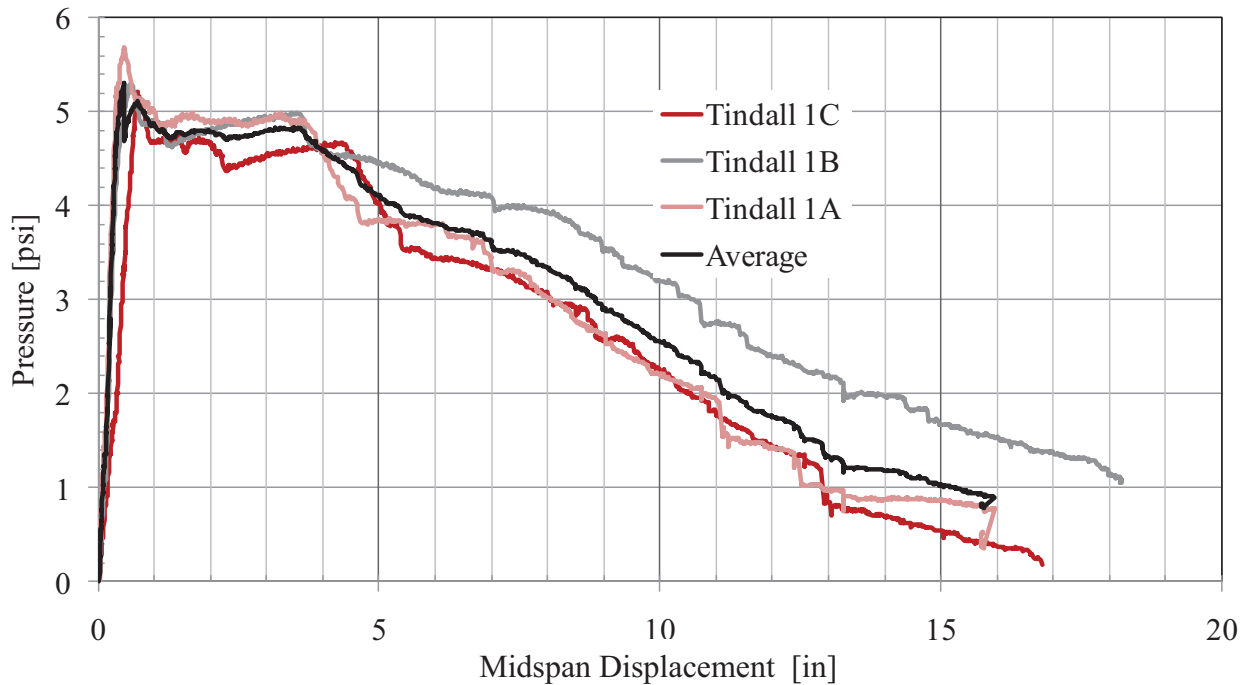

Figure 135. Tyn1 Pressure–Displacement Response

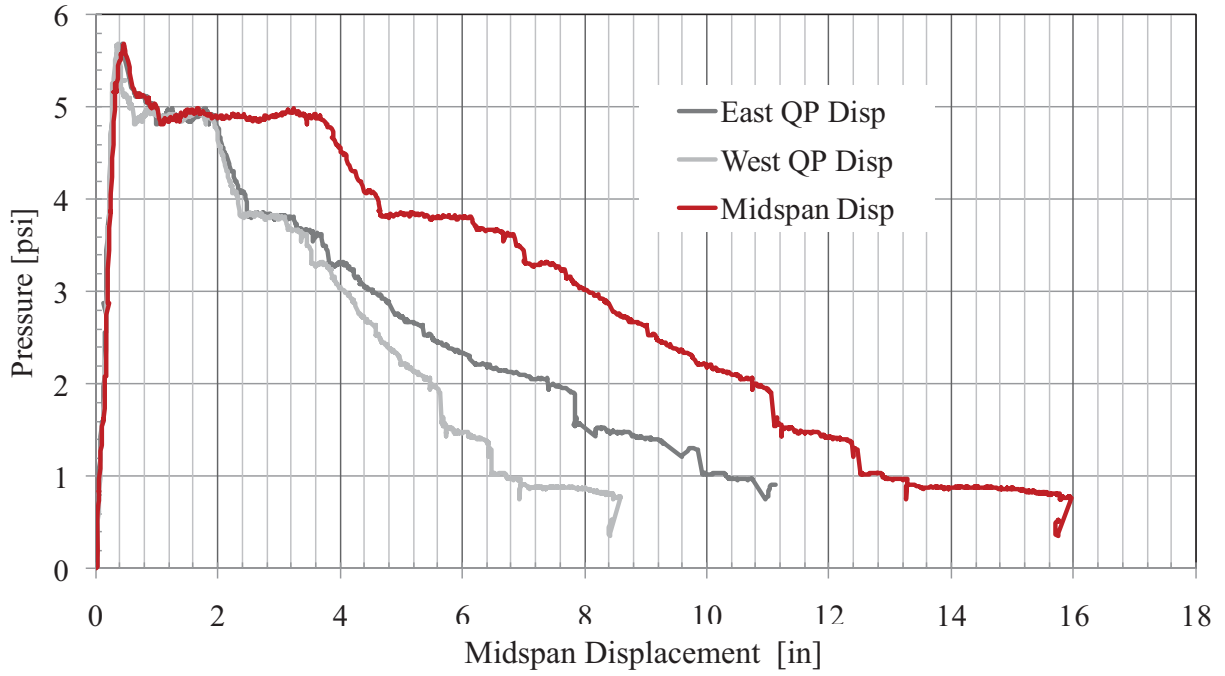

Figure 136. Tyn1-A Response

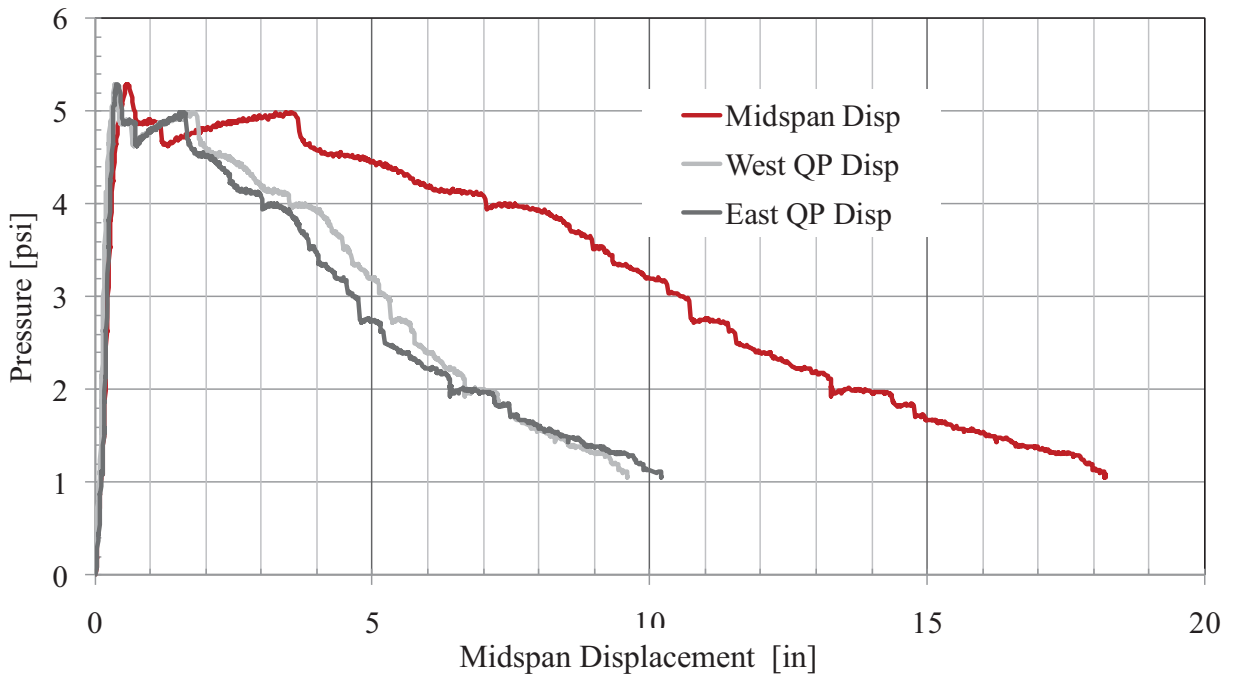

Figure 137. Tyn1-B Response

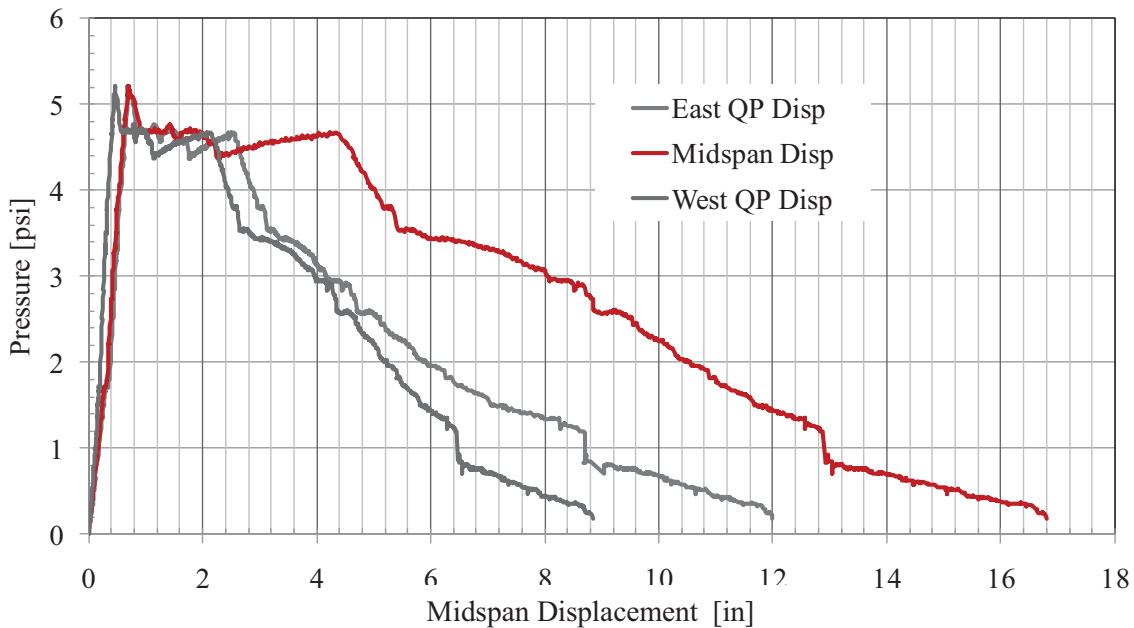

Figure 138. Tyn1-C Response

6.14. Tyn2 3-4-3 Specimen Performance (Unbonded)

Tyn2 consists of a partially composite 3-4-3 PC CSW panel fabricated with XPS insulation and Meadow Burke steel truss girder shear ties. The panel is prestressed with conventional transverse reinforcement in both the interior and exterior wythe. The panel cross-section and reinforcement details are illustrated in Figure 139 and Figure 140.

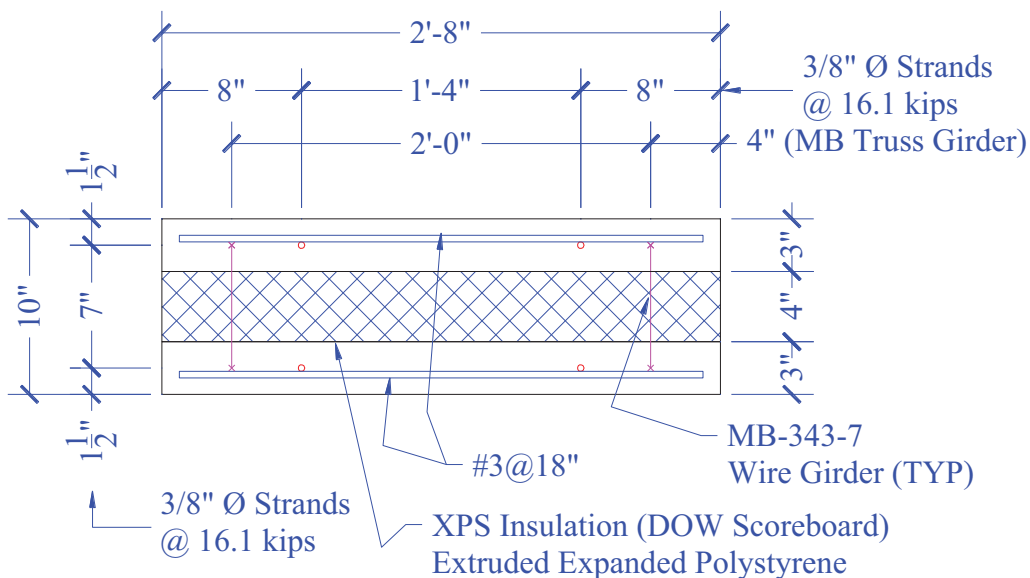

Figure 139. Tyn2 Cross-Section Detail

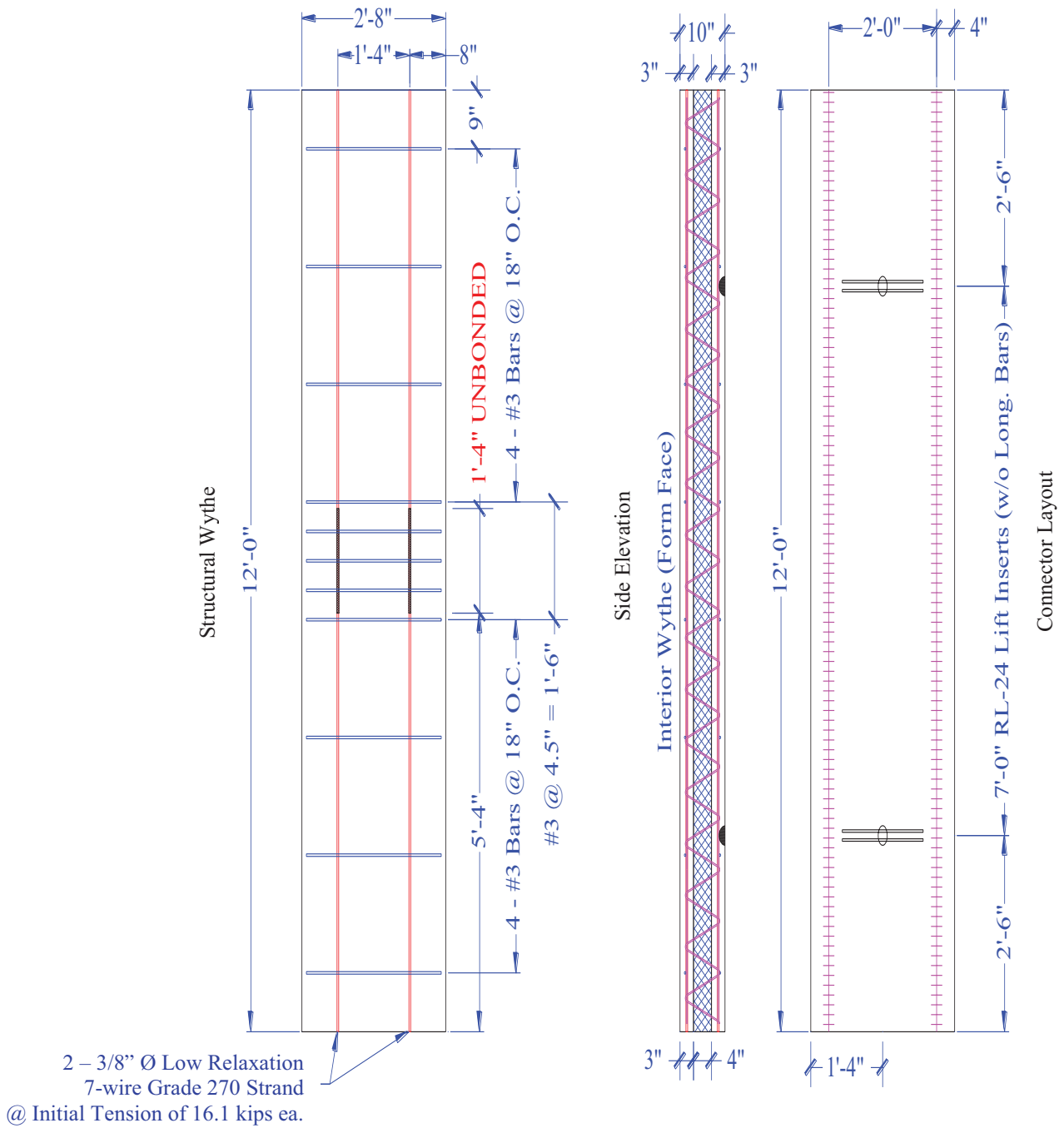

Figure 140. Tyn2 Panel Detail

The measured response is summarized in Table 30. The midspan pressure displacement for the three specimen are in Figure 141. The individual response of each panel and the quarter point displacements are included in Figure 142-144.

Table 30. Tyn2 Measured Response

Specimen	Age at Test [days]	Max Load [lbs]	Max Pressure [psi]	Corresponding Displacement [in]	East Slip [in]	West Slip [in]	Rot. [deg]	Measured Moment Capacity [k-in]
Tyn2-A	94	21847	5.69	0.84	NA	NA	0.802	327.7
Tyn2-B	101	18635	4.85	2.89	NA	NA	2.758	279.5
Tyn2-C	225	18987	4.94	4.35	NA	NA <td 4.157	284.8	
Average		19823	5.16	2.69	NA	NA	2.57	297.3

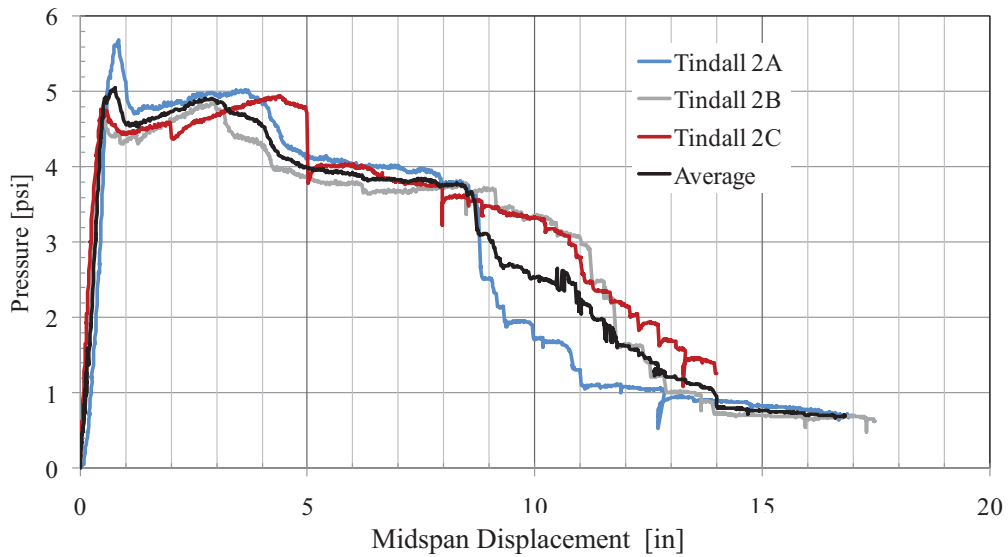

Figure 141. Tyn2 Pressure-Displacement Response

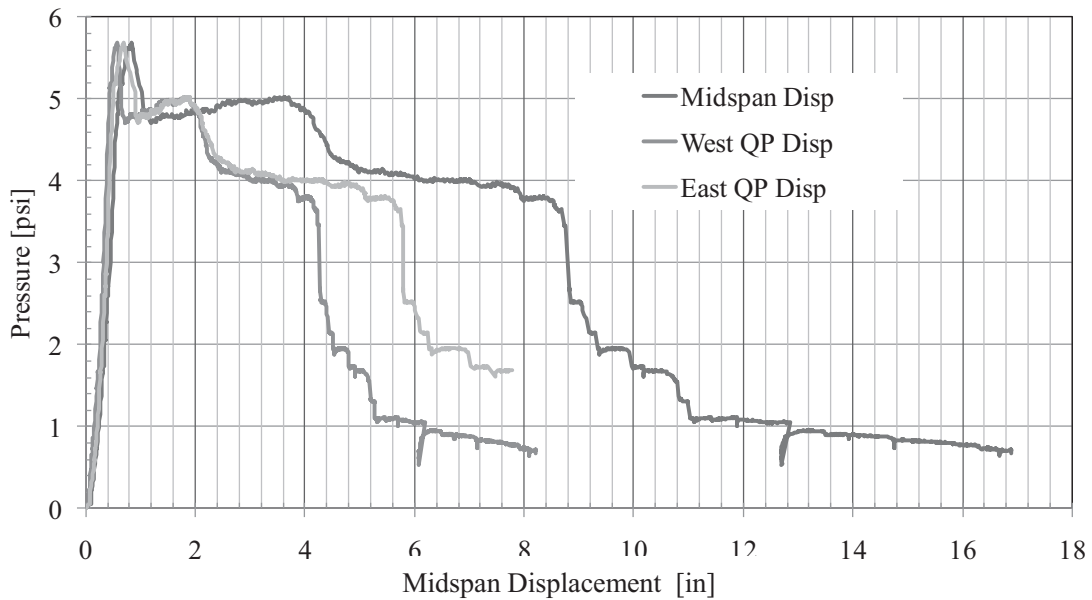

Figure 142. Tyn2-A Response

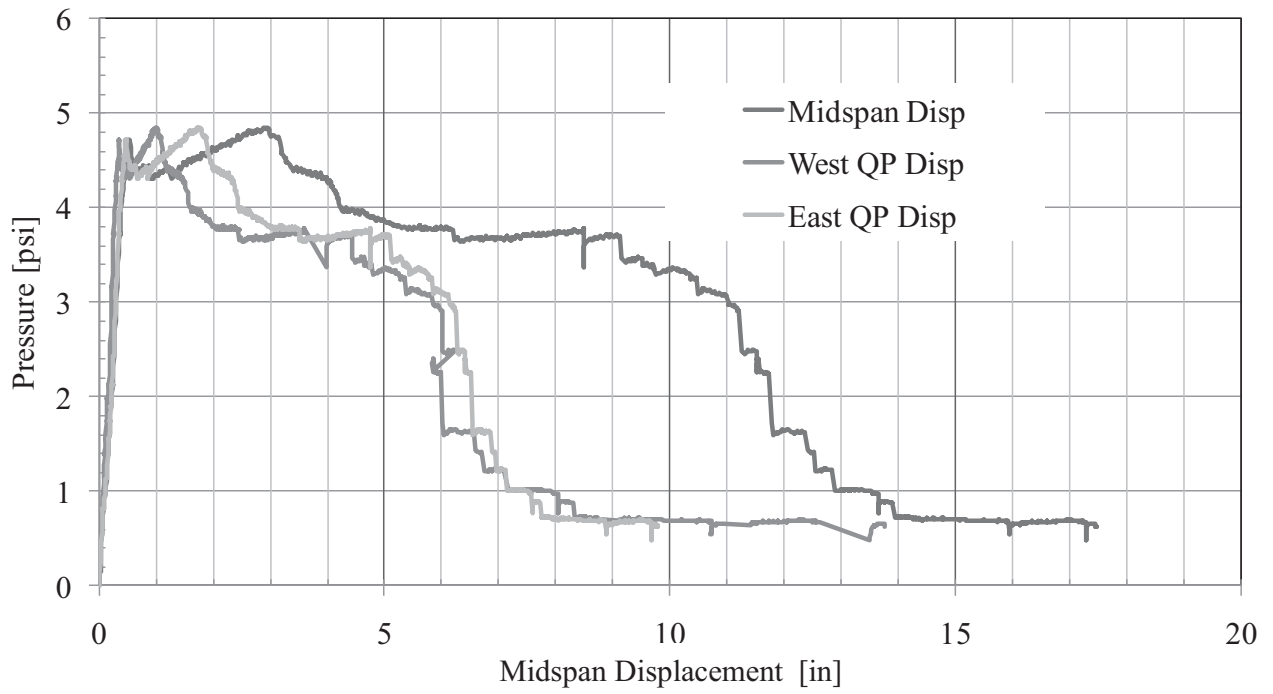

Figure 143. Tyn2-B Response

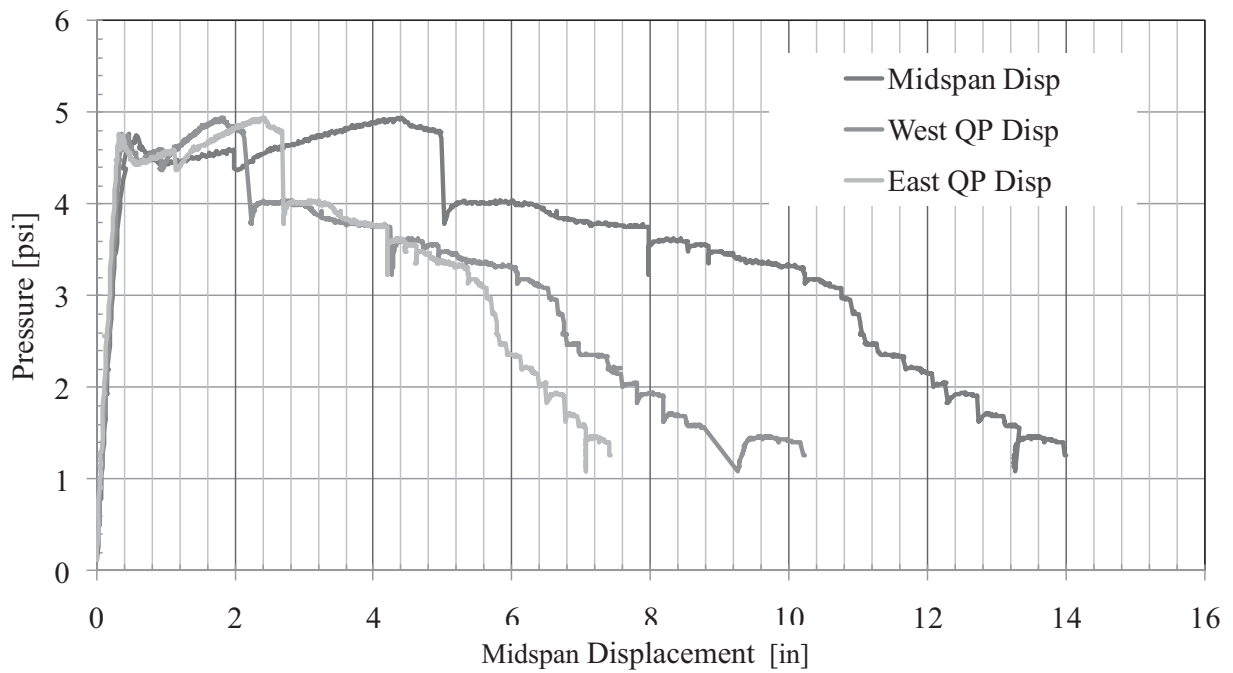

Figure 144. Tyn2-C Response

7. SINGLE-SPAN PANELS WITH END CONNECTION RESULTS

7.1. PCS10 3-3-3 Specimen Performance

PCS10 consists of a partially composite 3-3-3 PC CSW panel fabricated with XPS insulation and carbon fiber C-Grid® shear ties. The panel is prestressed with WWR transverse reinforcement in both the interior and exterior wythe. The panel cross-section and reinforcement details are illustrated in Figure 145 and Figure 146.

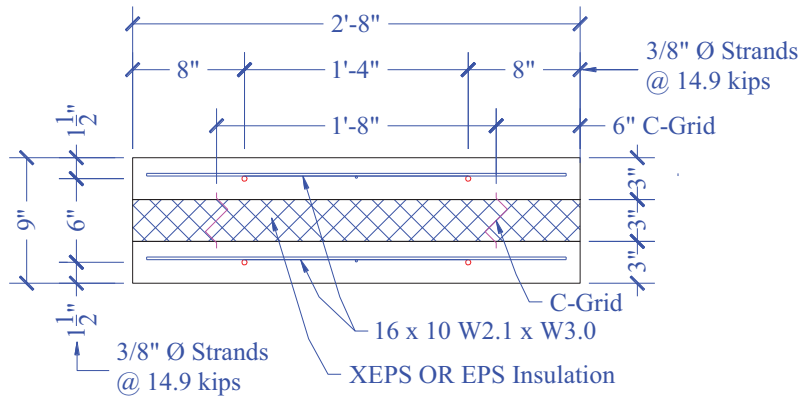

Figure 145. PCS10 Cross-Section Detail

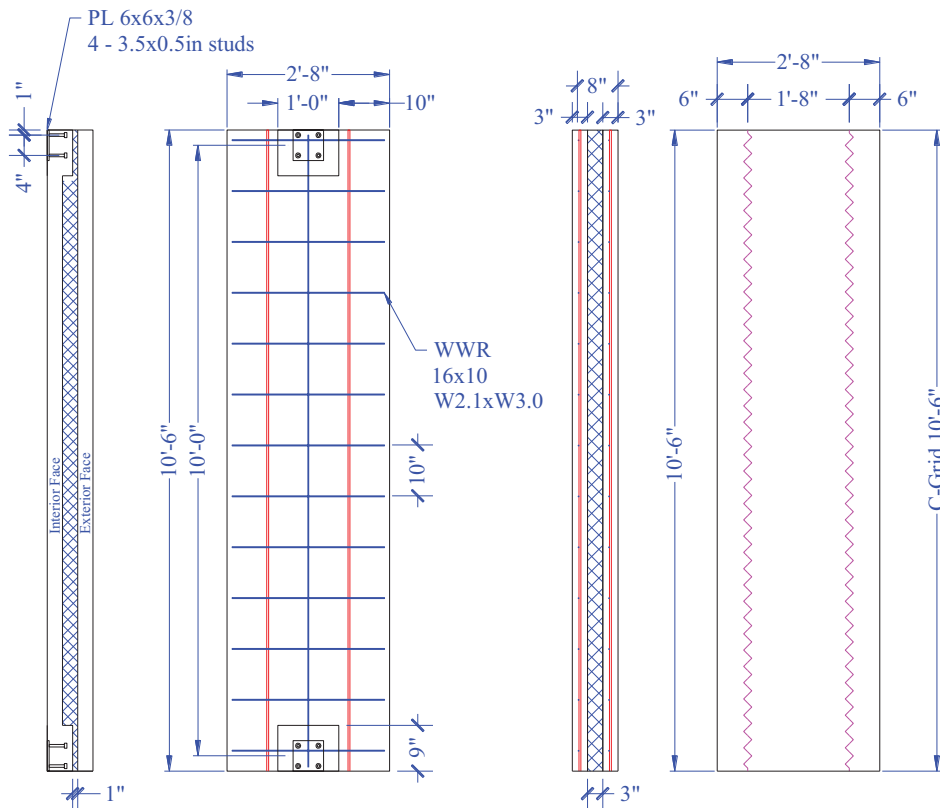

Figure 146. PCS10 Panel Detail

The measured response is summarized in Table 31. The midspan pressure displacement and moment-support rotation for the two specimen are in Figure 147 and Figure 148. The individual response of each panel and the displacement and rotation responses are included in Figure 149 and Figure 150. Figure 151 and Figure 152 show a picture representation of the samples post-test.

The rebound response exhibited less ductility and strength than that of the inbound response. The reduction was due to the failure of the panel at the support and failure of the stud group weld to the plate as illustrated in the images in Figure 152.

Table 31. PCS10 Measured Response

Specimen	Age at Test [days]	Max Load [lbs]	Max Pressure [psi]	Corresponding Displacement [in]	East Slip [in]	West Slip [in]	Rot. [deg]	Measured Moment Capacity [k-in]
PCS10-A	72	19785	5.152	2.248	-	-	2.145	296.78
PCS10-B	85	17007	4.429	1.283	-	-	1.225	255.11
Average		18396	4.791	1.765	-	-	1.685	275.94

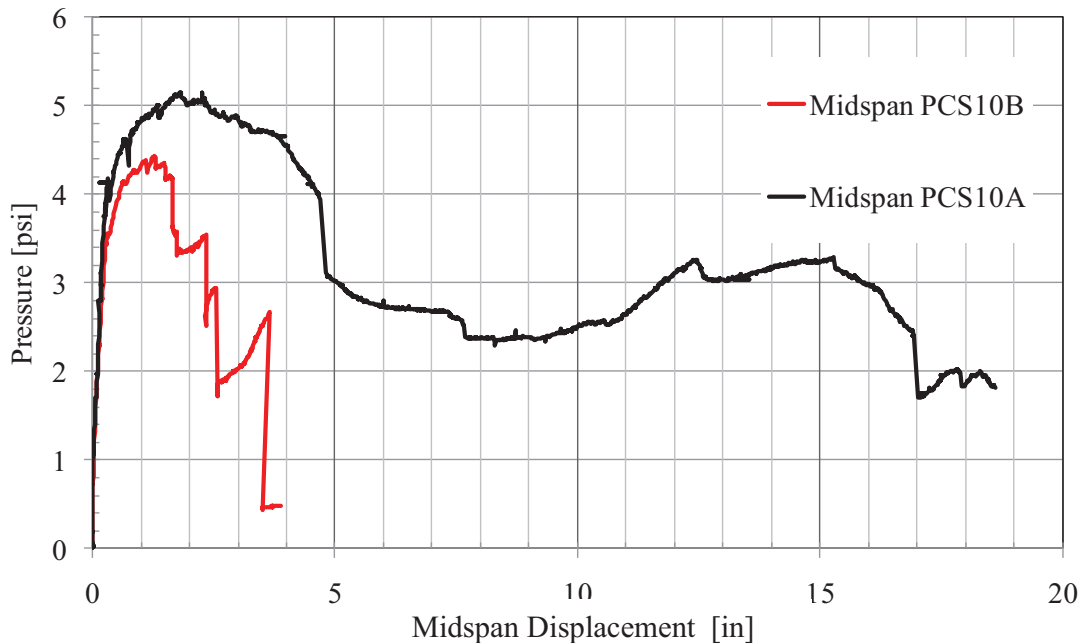

Figure 147. PCS10 Pressure–Displacement Response

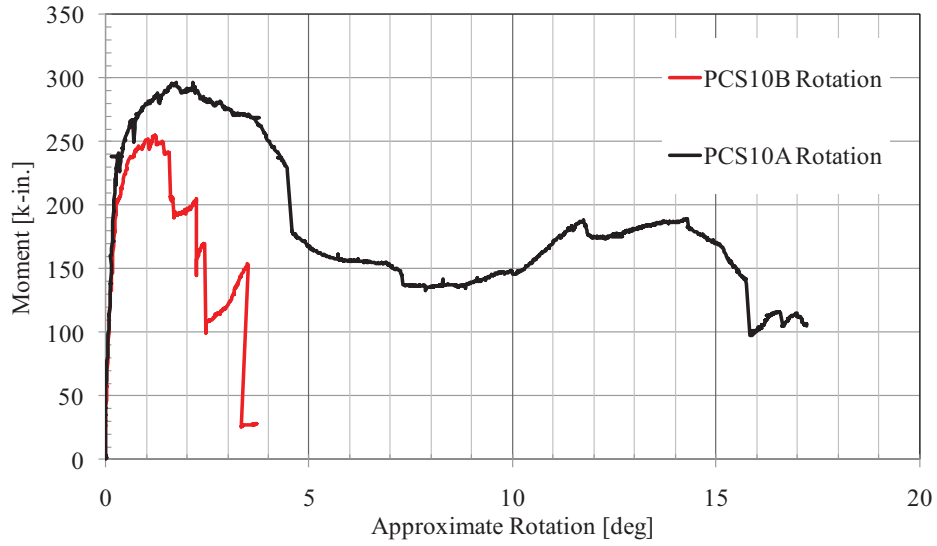

Figure 148. PCS10 Moment–Rotation Response

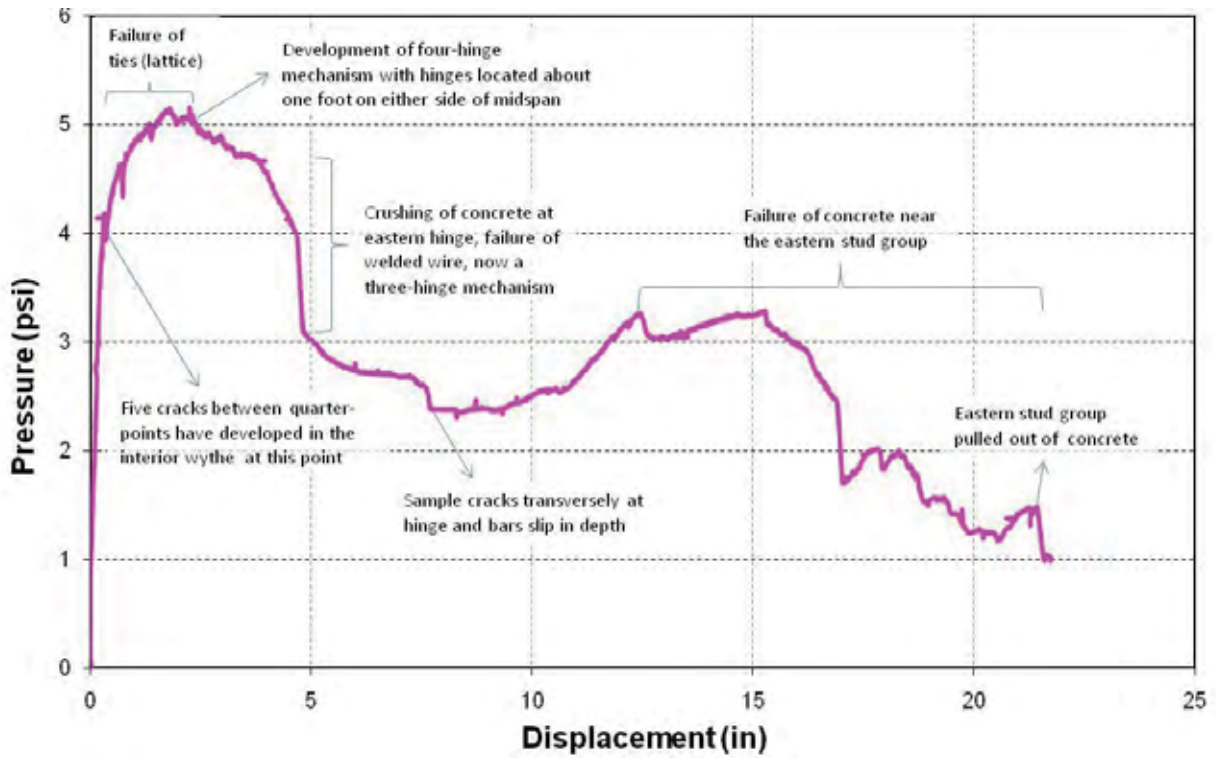

Figure 149. PCS10-A Inbound Response

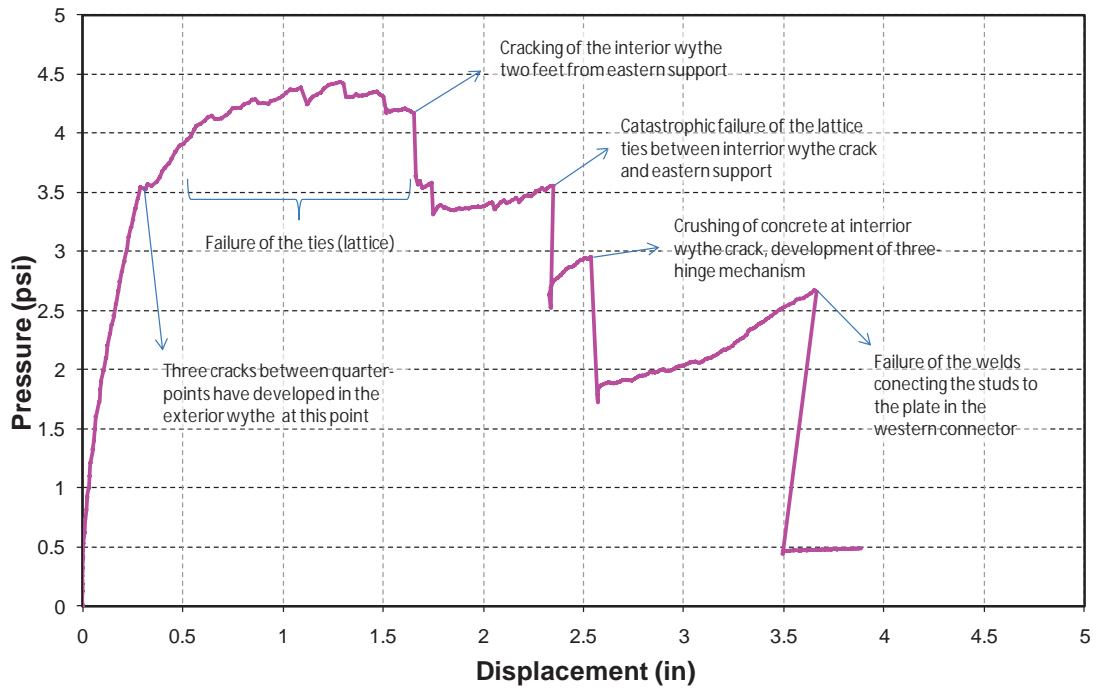

Figure 150. PCS10-B Rebound Response



Figure 151. PCS10-A Inbound Response



Figure 152. PCS10-B Rebound Response

7.2. PCS11 3-3-3 Specimen Performance

PCS11 consists of a partially composite 3-3-3 PC CSW panel fabricated with XPS insulation and glass fiber THERMOMASS® composite shear pins. The panel is prestressed with WWR transverse reinforcement in both the interior and exterior wythe. The panel cross-section and reinforcement details are illustrated in Figure 153 and Figure 154.

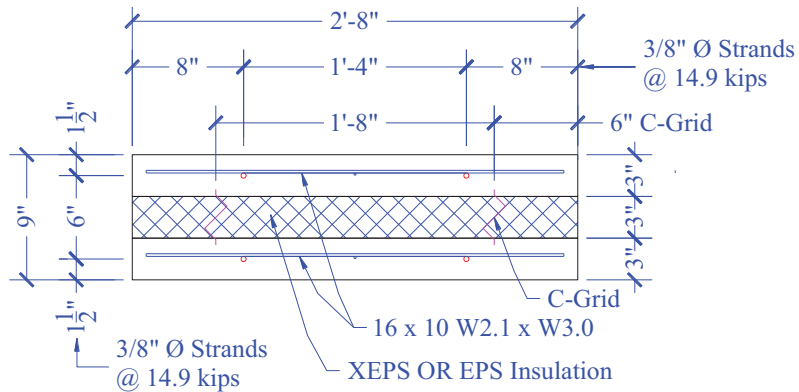

Figure 153. PCS11 Cross-Section Detail

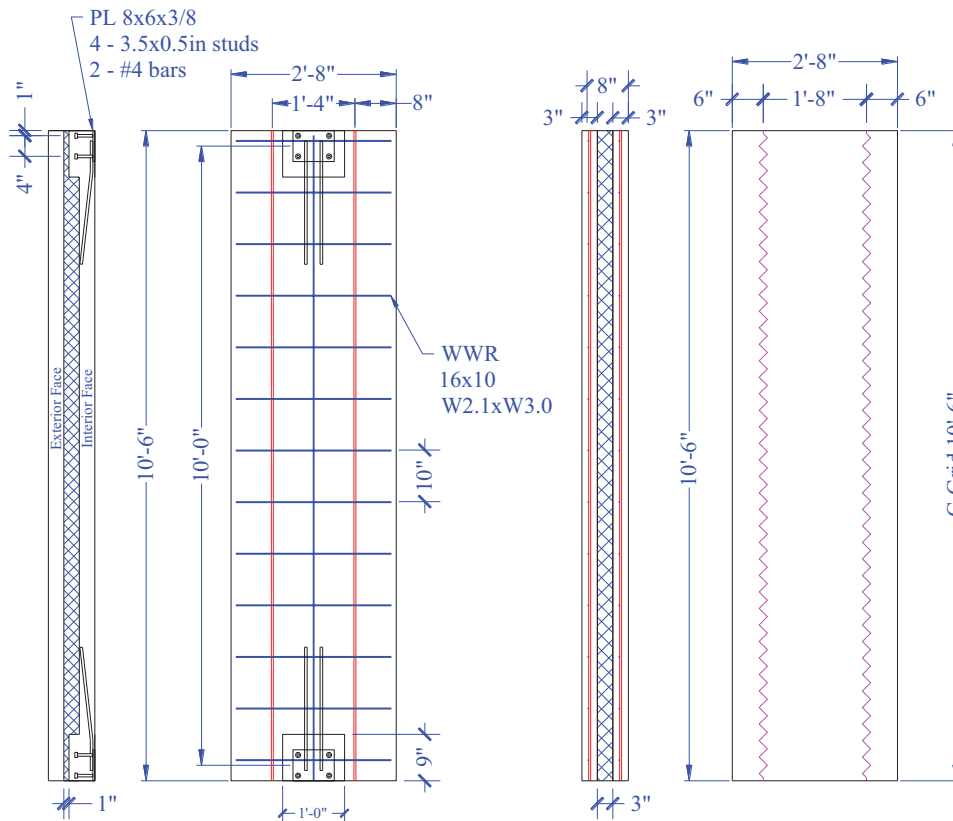

Figure 154. PCS 11 Panel Detail

The measured response is summarized in Table 32. The midspan pressure displacement and moment–support rotation for the two specimen are in Figure 155 and Figure 156. The individual response of each panel and the displacement and rotation responses are included in Figure 157 and Figure 158. Figure 159 and Figure 160 show a picture representation of the samples post-test.

The rebound response exhibited less ductility and strength than that of the inbound response. The reduction was due to the failure of the panel at the support and failure of the stud group weld to the plate as illustrated in the images in Figure 160.

Table 32. PCS11 Measured Response

Specimen	Age at Test [days]	Max Load [lbs]	Max Pressure [psi]	Corresponding Displacement [in]	East Slip [in]	West Slip [in]	Rot. [deg]	Measured Moment Capacity [k-in]
PCS11-A	72	18956	4.936	2.386	-	-	2.277	284.33
PCS11-B	86	22039	5.739	3.521	-	-	3.359	330.59
Average		20497	5.34	2.95	-	-	2.82	307.5

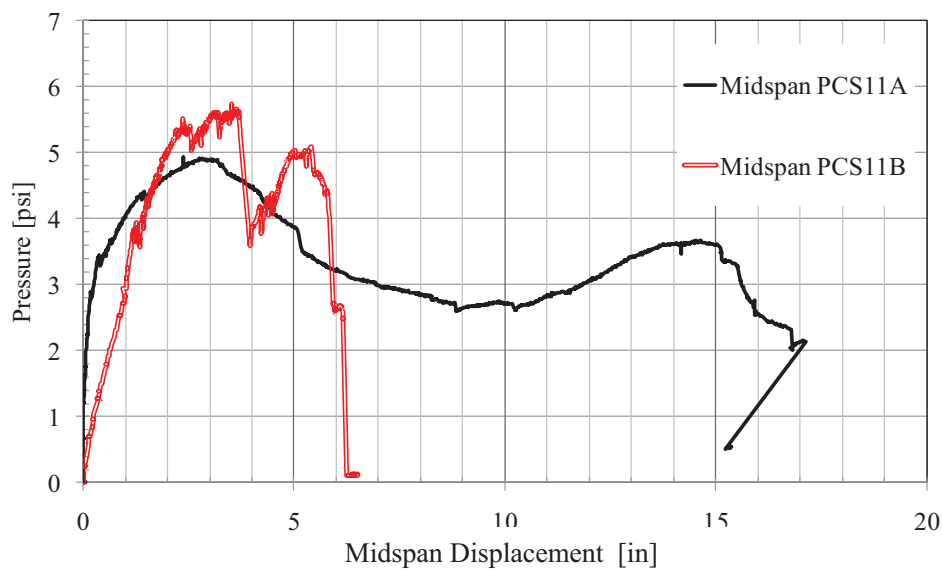

Figure 155. PCS11 Pressure–Displacement Response

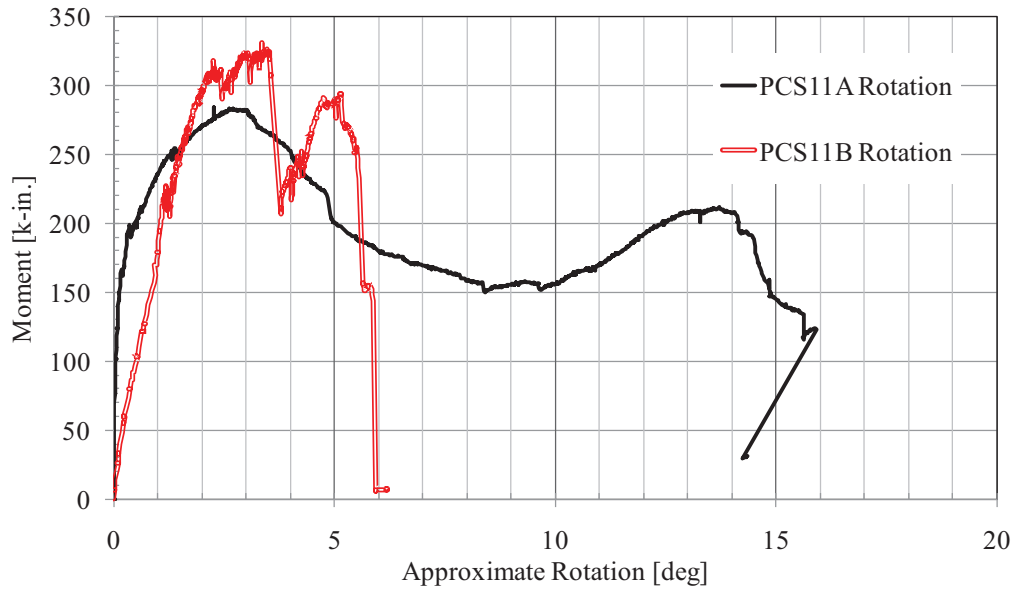

Figure 156. PCS11 Moment-Rotation Response

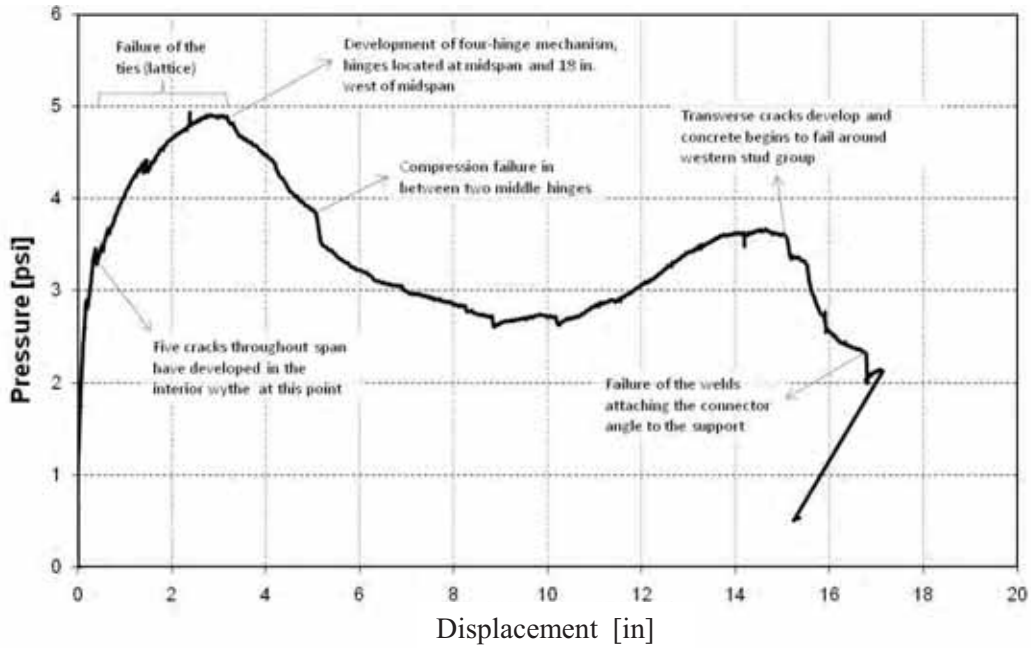

Figure 157. PCS11-A Response

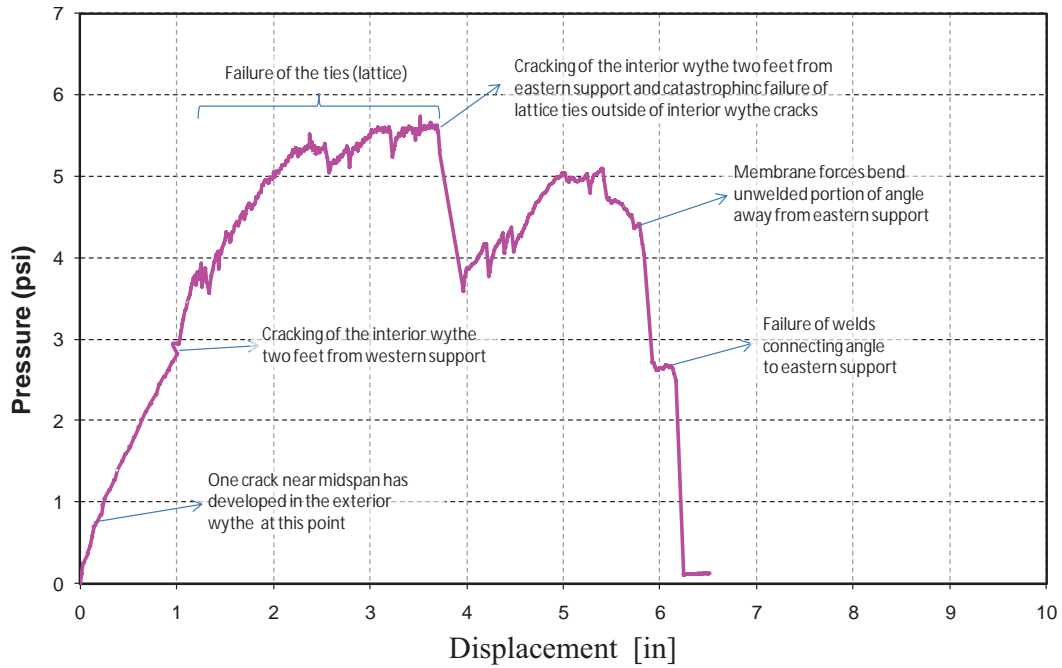

Figure 158. PCS11-B Response



Figure 159. PCS11 Panel Inbound Response (A)



Figure 160. PCS11 Panel Rebound Response (B)

8. MULTI SPAN PANEL RESULTS

8.1. PCD1 3-3-3 Specimen Performance

PCD1 consists of two-span partially composite 3-3-3 PC CSW panel fabricated with XPS insulation and glass fiber THERMOMASS® composite shear pins. The panel is prestressed with WWR transverse reinforcement in both the interior and exterior wythe. The panel cross-section and reinforcement details are illustrated in Figure 161 and Figure 162.

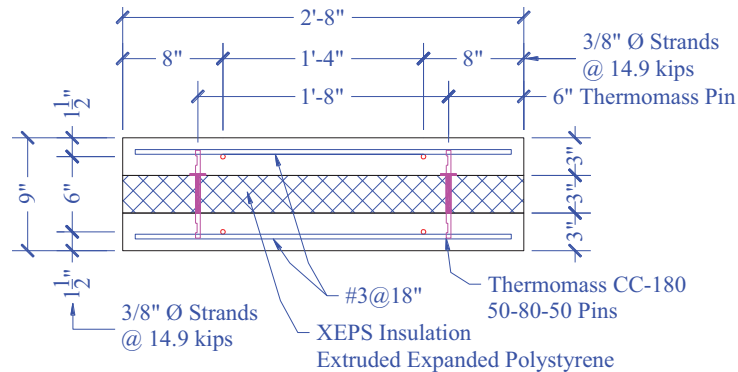

Figure 161. PCD1 Cross-Section Detail

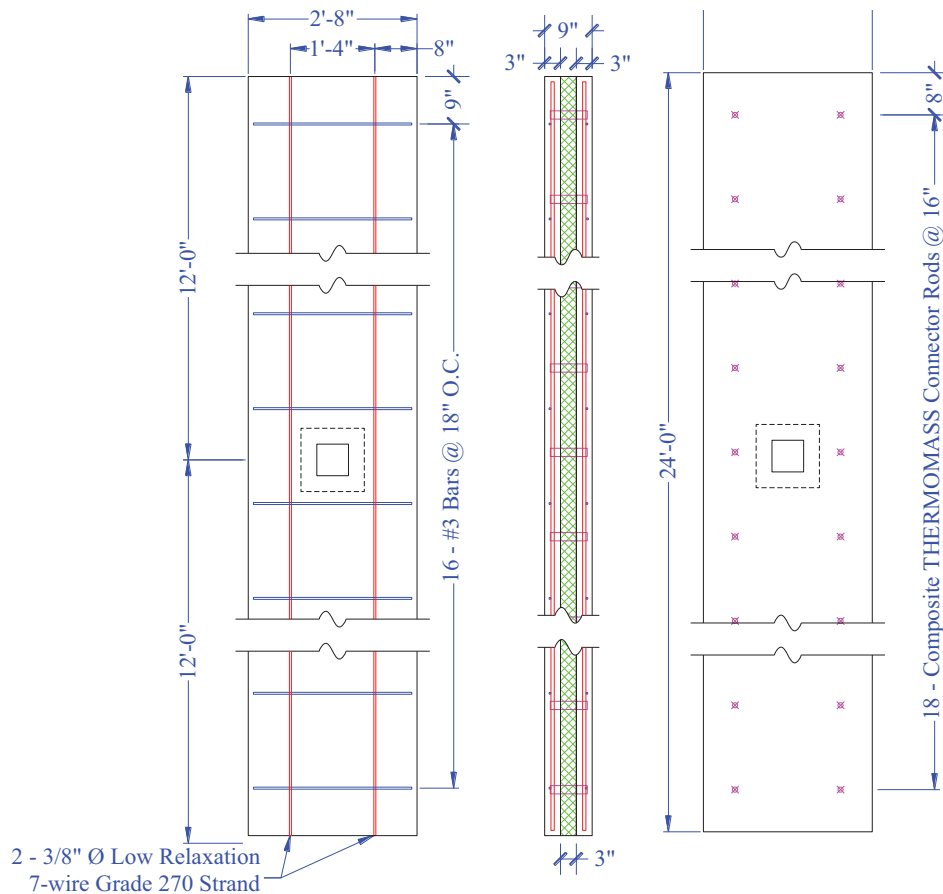

Figure 162. PCD1 Panel Detail

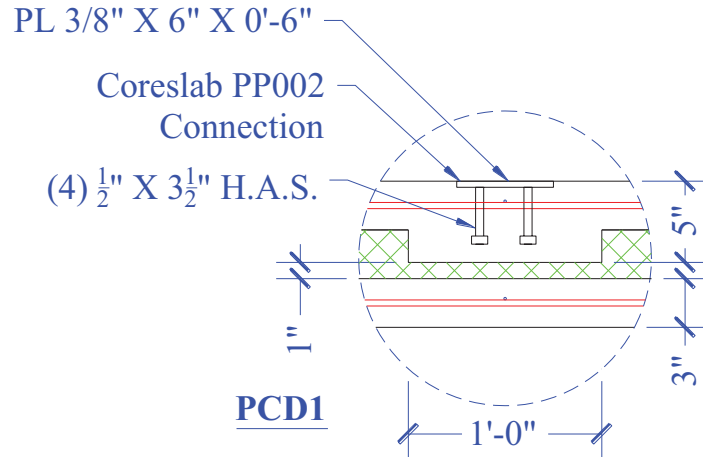

Figure 163. Coreslab Two-span Panel PCD1 Midspan Connection

The material properties for the specimen and the measured response are summarized in Table 16 and Table 34. The midspan pressure displacement for the three specimen follows in Figure 164. The individual response of each panel and the end slips, damage photos, and quarter point displacements are included in Figure 165-Figure 171.

Table 33. PCD1 Materials Properties

Property	Value
Design Unit Weight	150 pcf
Design Compression Strength at Release, f_{ci}	3500 psi
Design Compressive Strength at 28-days, f'_c	5000 psi
Approximate Compressive Strength PCD1A	9228 psi
Approximate Compressive Strength PCD1B	9201 psi
Approximate Compressive Strength PCD1-B	9192 psi

Table 34. PCD1 Measured Response

Specimen	Age at Test [days]	Max Load [lbs]	Max Pressure [psi]	East Corresponding Displacement [in]	West Corresponding Displacement [in]	East Slip [in]	West Slip [in]	Measured (+) Moment Capacity ($9/64wL^2$)	Measured (-) Moment Capacity ($1/4*wL^2$)
PCD1-A	60	34865.6	4.006	5.574	4.736	0.487	0.288	333.4	593
PCD1-B	63	34731.4	3.990	2.727	2.885	0.175	0.158	332.1	590
PCD1-C	64	36338.5	4.175	7.284	4.741	0.514	0.477	347.5	618
Average		35311.8	4.057	5.195	4.121	0.392	0.308	337.7	600.3

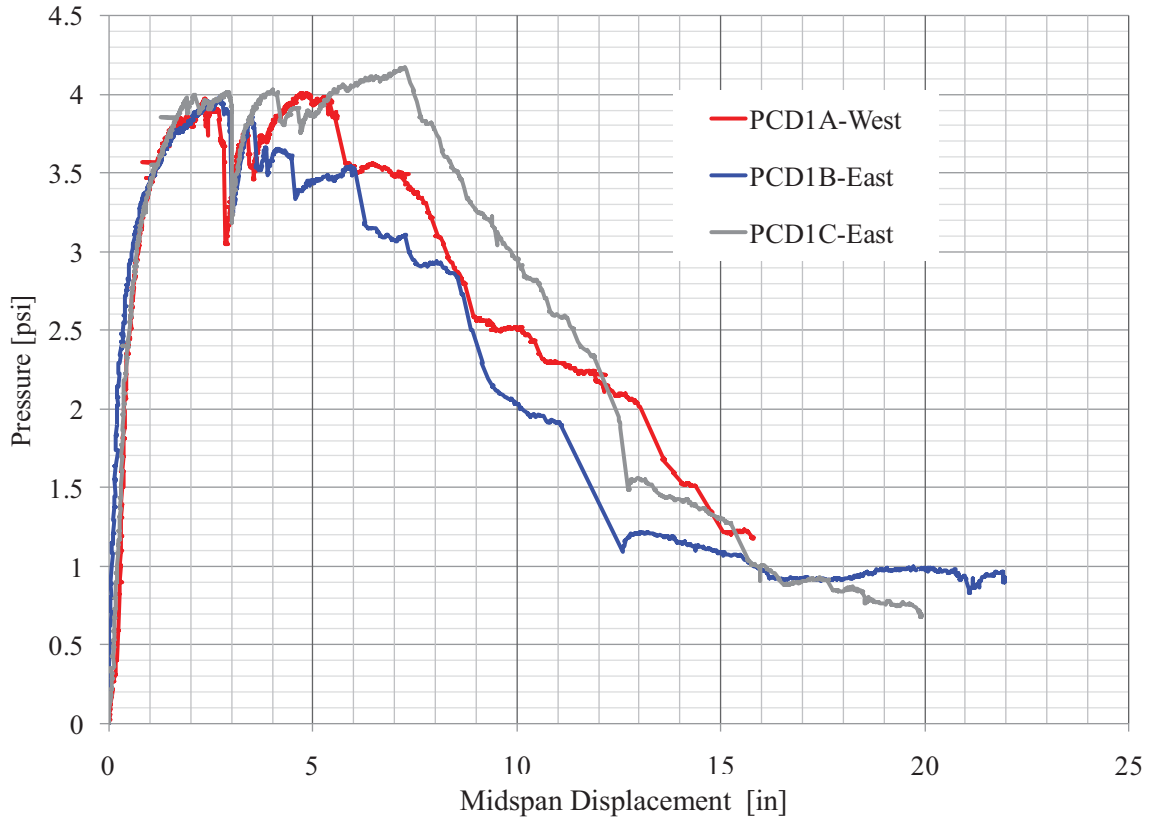

Figure 164. PCD1 Pressure–Displacement Response

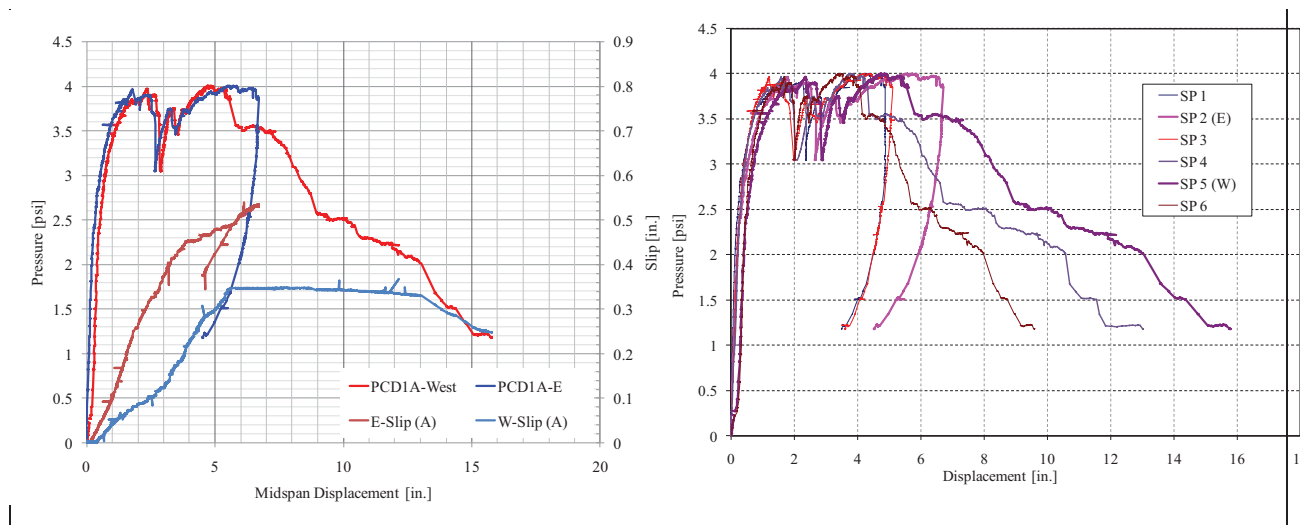

Figure 165. PCD1-A Response



Figure 166. PCSD1-A Punching Failure of Connection

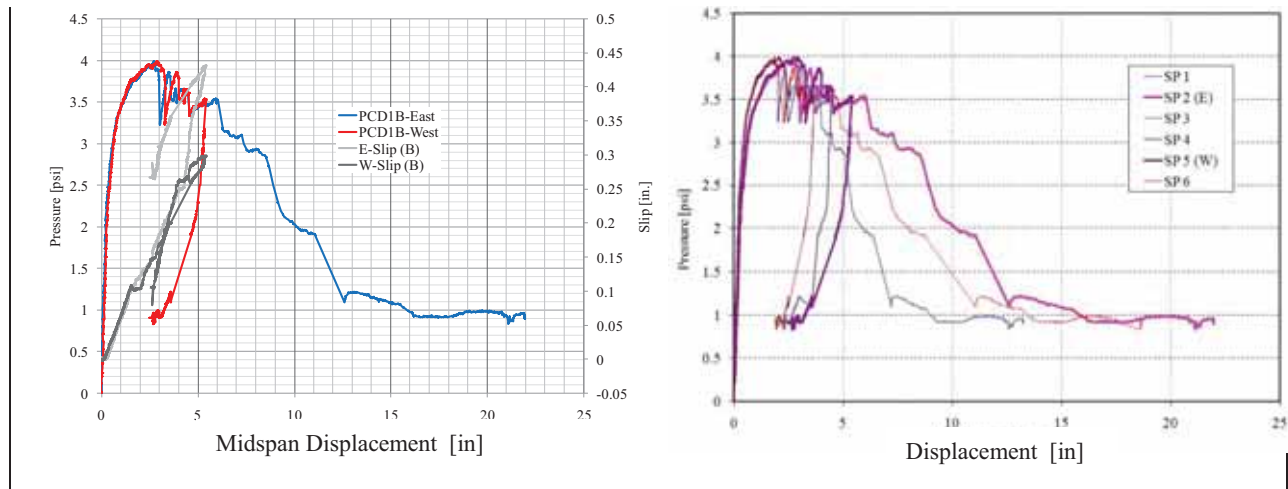

Figure 167. PCD1-B Response



Figure 168. PCD1-B Punching Failure of Connection

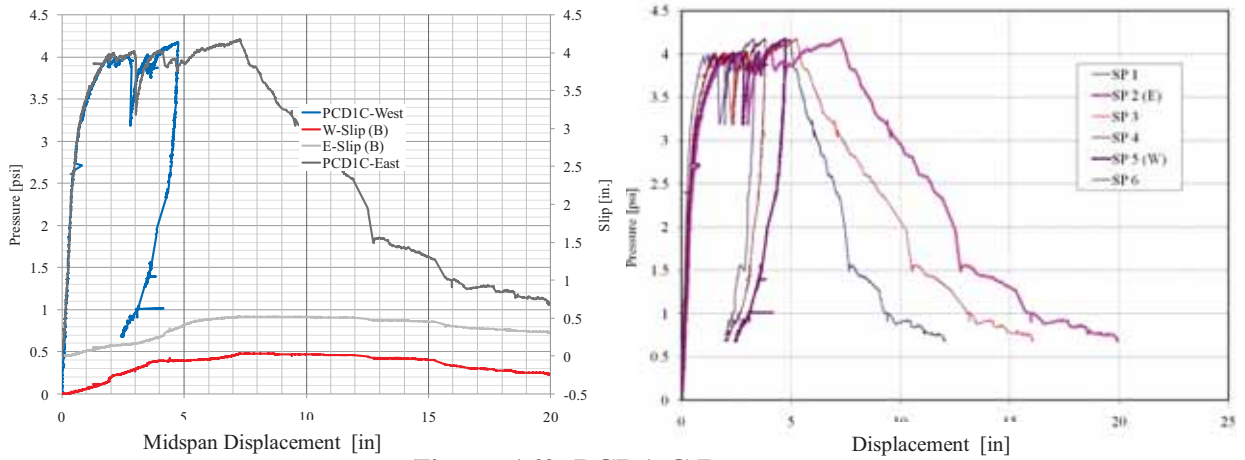
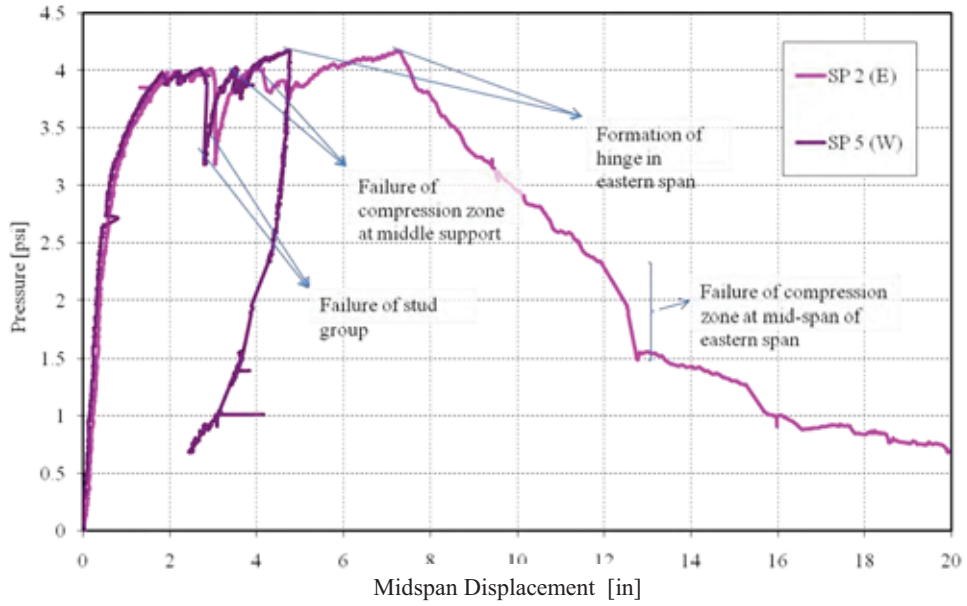

Figure 169. PCD1-C Response



Figure 170. PCD1-C Punching Failure of Connection



Figure 171. PCD1-C Failure of Panel

8.2. PCD2 3-3-3 Specimen Performance

PCD2 consists of a partially composite 3-2-3 PC CSW panel fabricated with EPS insulation and carbon fiber C-Grid® shear ties. The panel is prestressed with WWR transverse reinforcement in both the interior and exterior wythe. The panel cross-section and reinforcement details are illustrated in Figure 172 and Figure 173. The midspan support connection is shown in Figure 174.

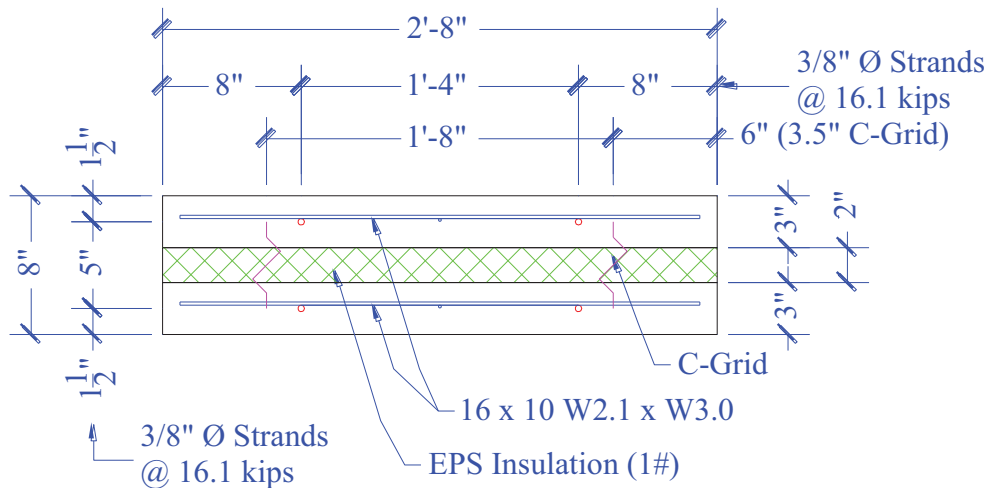

Figure 172. PCD2 Cross-Section Detail

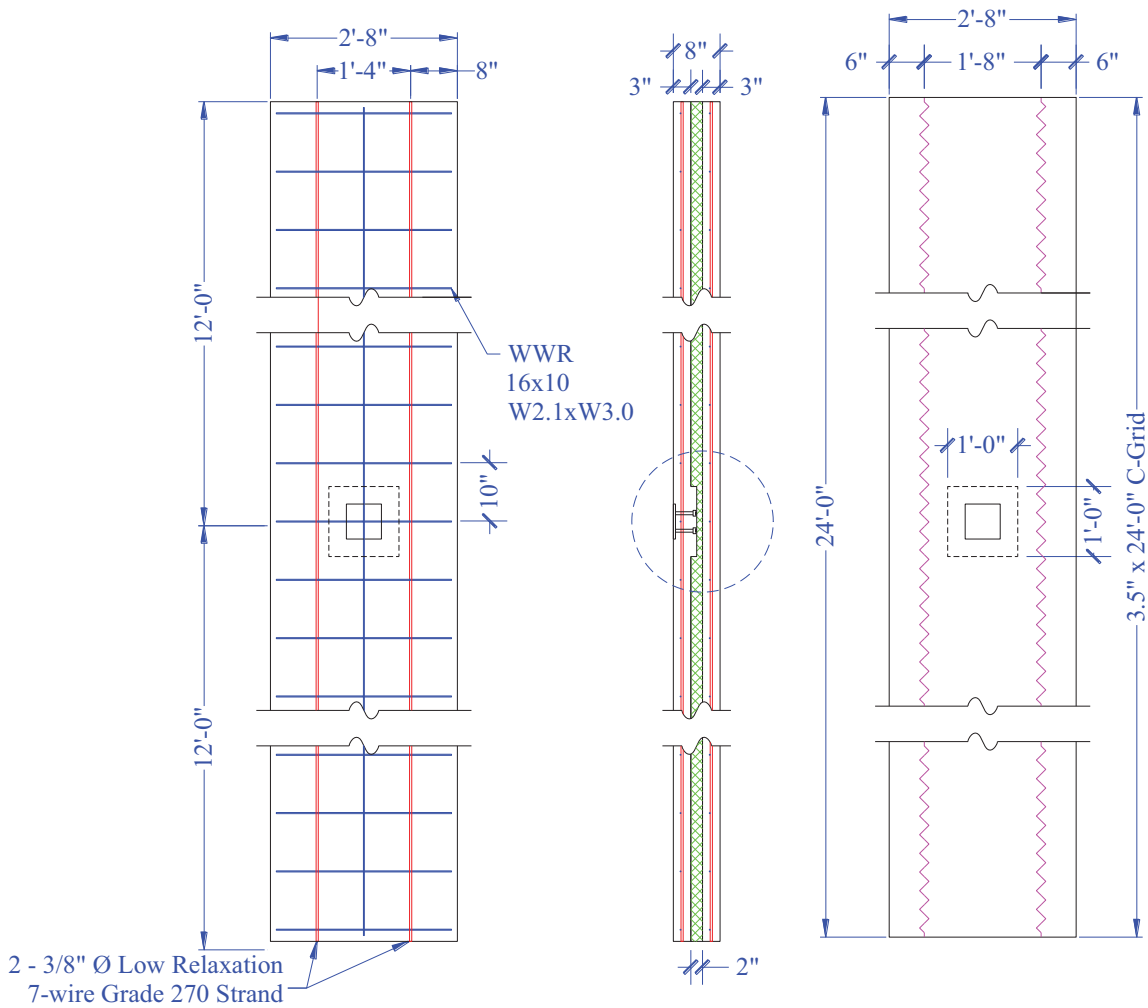

Figure 173. PCD2 Panel Detail

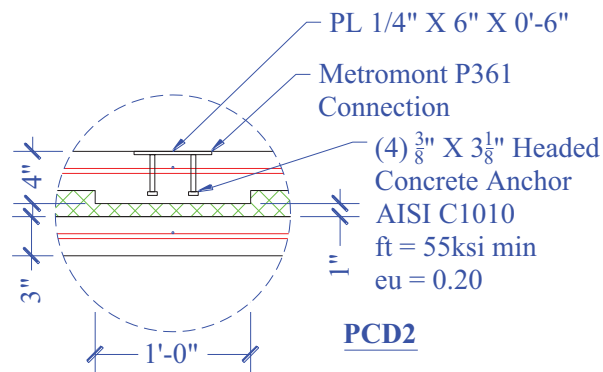

Figure 174. PCD2 Midspan Connection Detail

The measured response is summarized in Table 35. The midspan pressure displacement for the three specimen follows in Figure 175. The individual response of each panel and the end slips, damage photos, and quarter point displacements are included in Figure 176 through Figure 179.

Table 35. PCD2 Measured Response

Specimen	Age at Test [days]	Max Load [lbs]	Max Pressure [psi]	East Corresponding Displacement [in]	West Corresponding Displacement [in]	East Slip [in]	West Slip [in]	Measured (+) Moment Capacity (9/64wL ²)	Measured (-) Moment Capacity (1/4*wL ²)
PCD2-A	28	36762.0	4.224	3.295	3.620	0.155	0.289	351.5	625
PCD2-B	29	42539.2	4.887	0.499	2.580	0.002	0.157	406.8	723
PCD2-C	30	40551.5	4.659	1.709	0.738	0.033	0.002	387.8	689
Average		39950.9	4.590	1.834	2.312	0.063	0.149	382.0	679

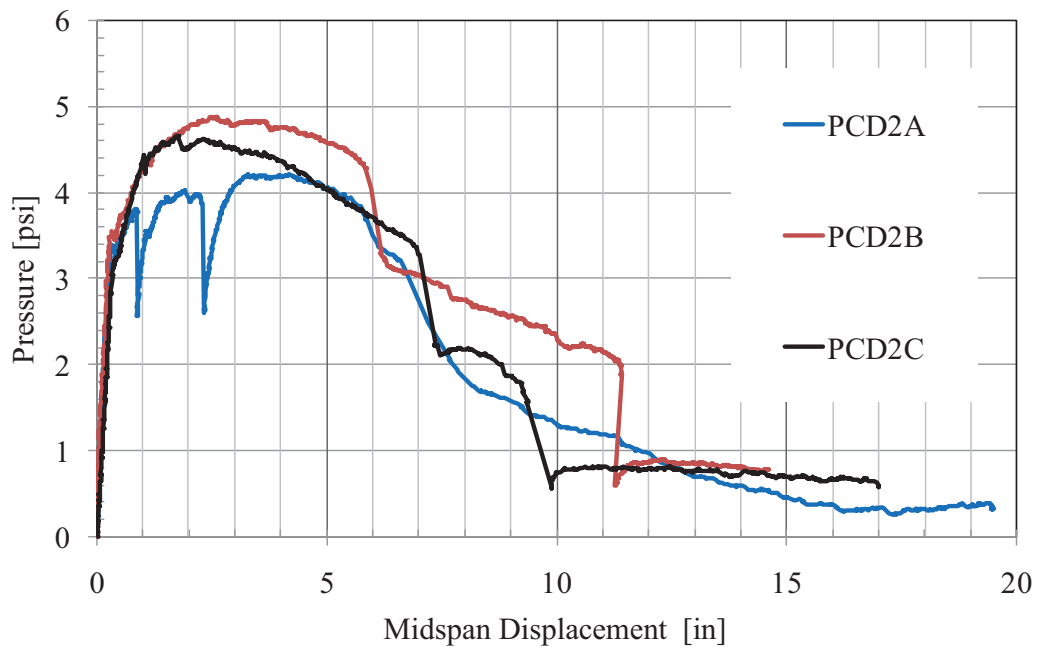

Figure 175. PCD2 Pressure–Displacement Response

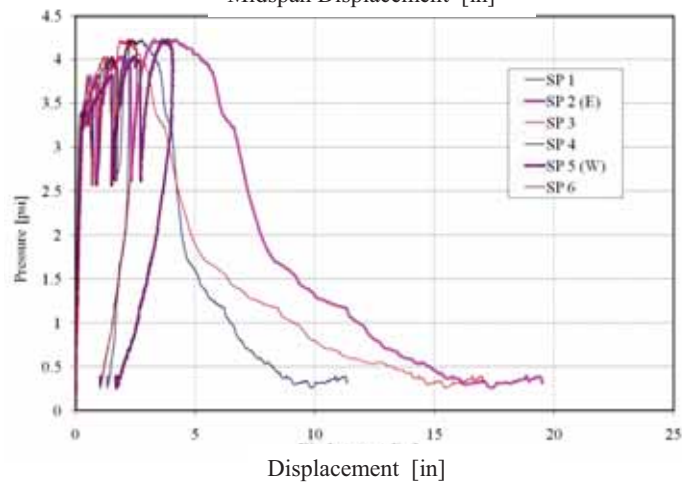
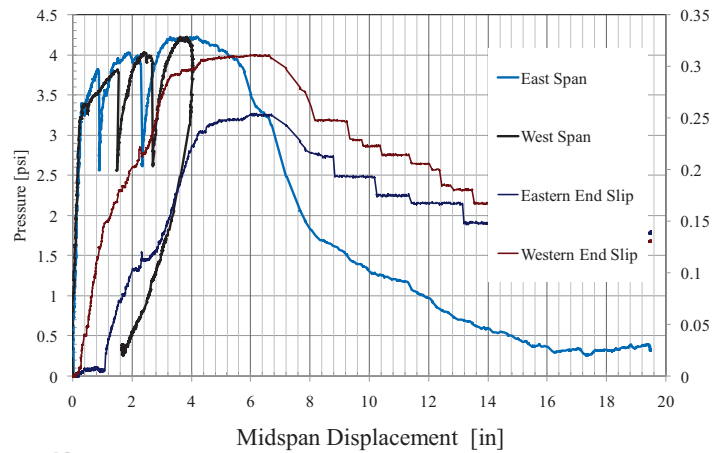
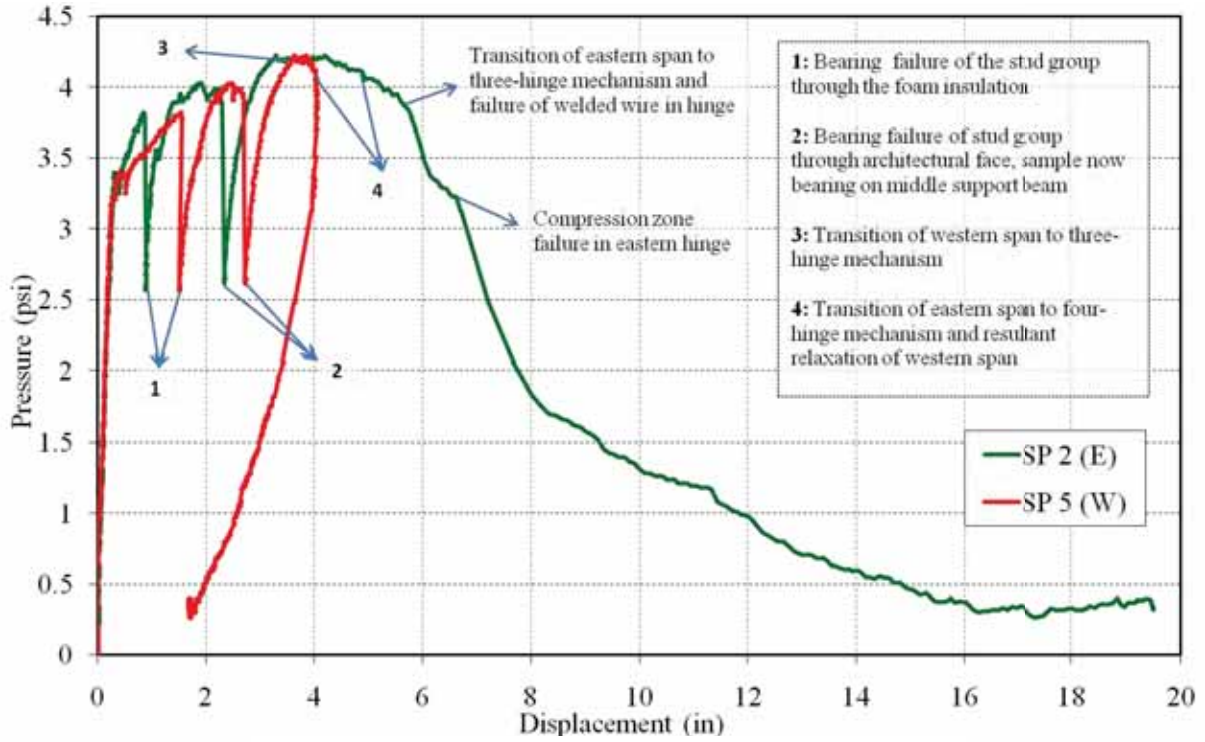

Figure 176. PCD2-A Response

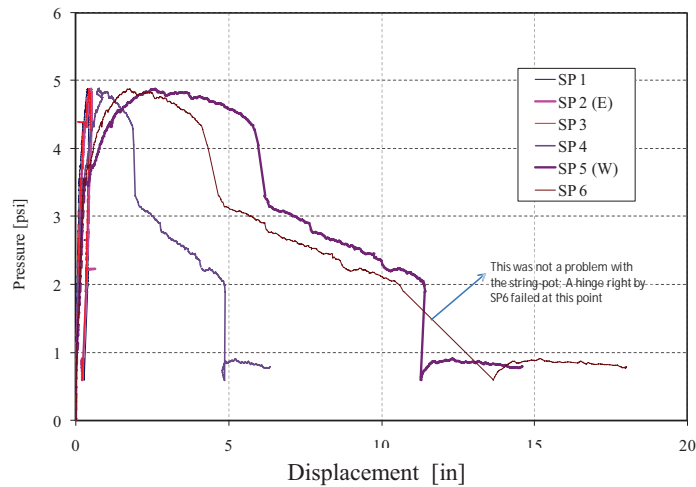
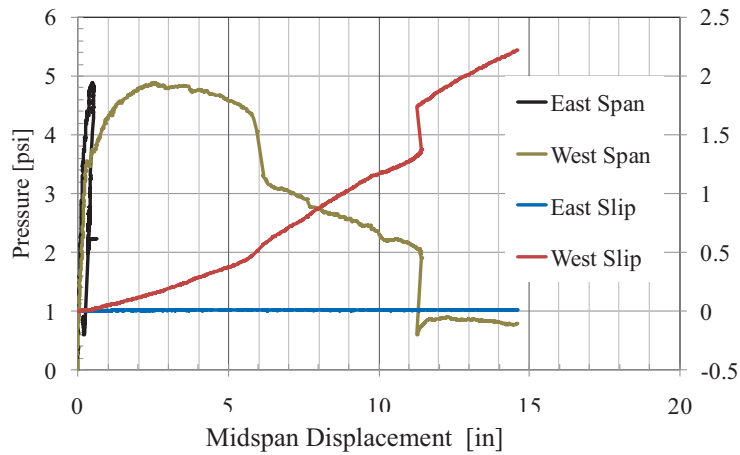
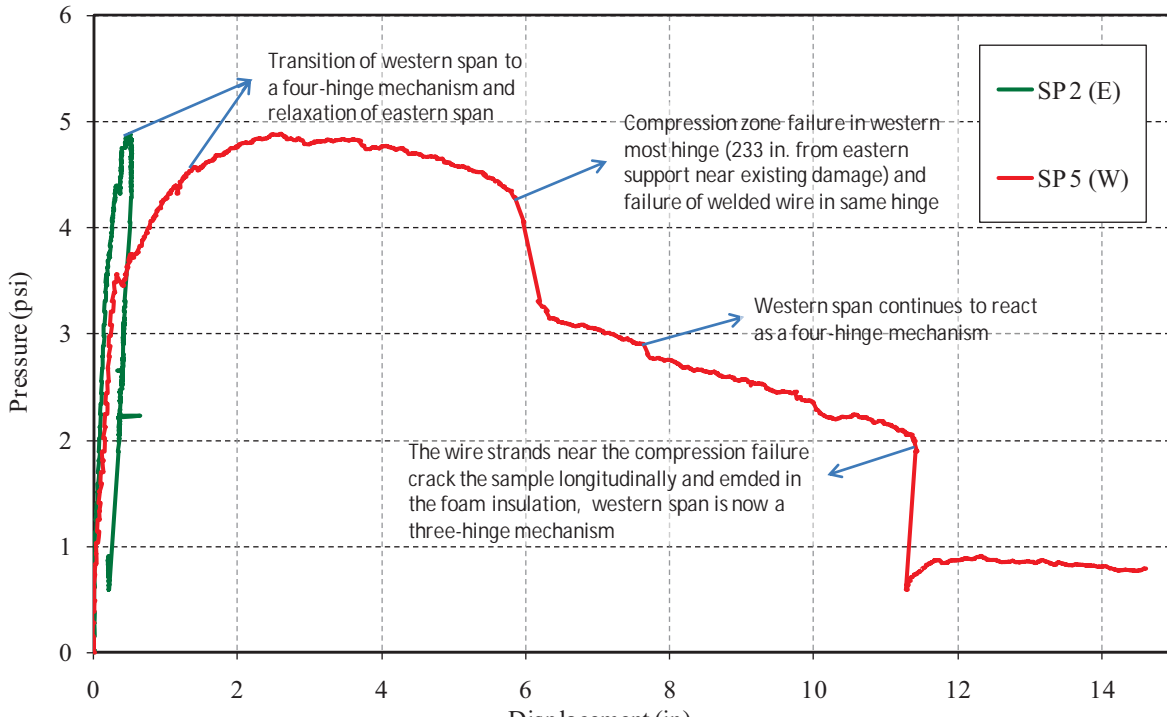

Figure 177. PCD2-B Response

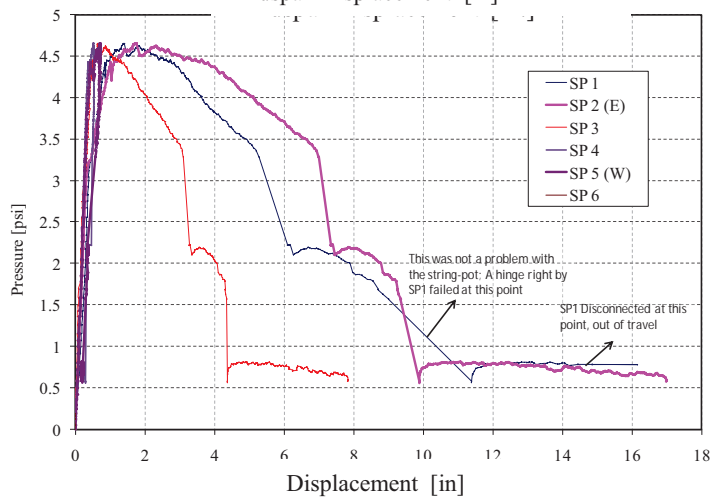
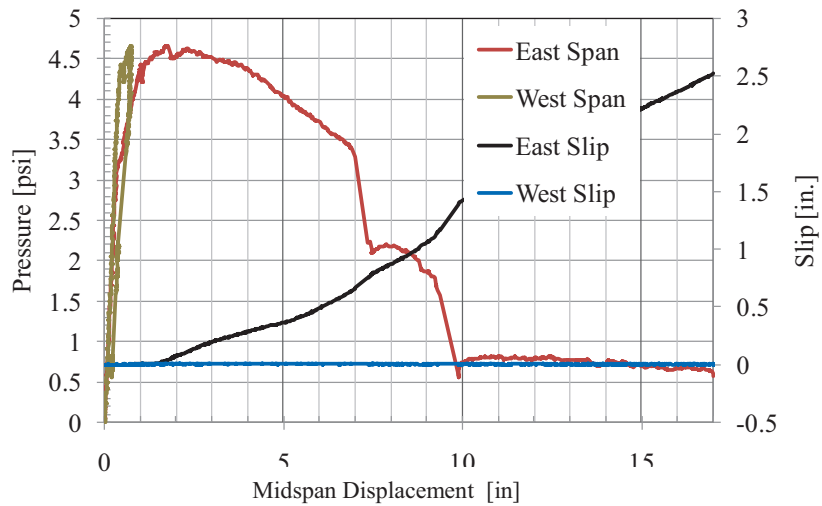
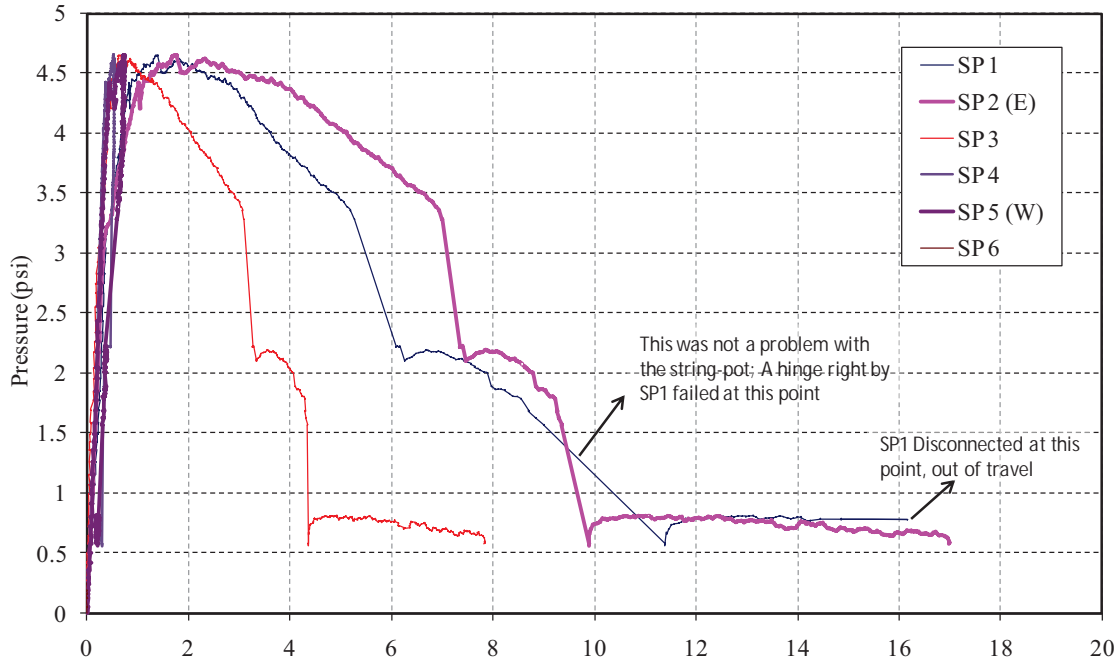

Figure 178. PCD2-C Response



Figure 179. PCD2 Panel Response (A, B, C)

8.3. TS3-A and B 6-2-3 Specimen Performance

TS3-A and B consist of a non-composite 6-2-3 PC CSW panel fabricated with XPS insulation and glass fiber THERMOMASS® non-composite shear pins. The panel is conventionally reinforced with rebar transverse reinforcement in the interior wythe and WWR in the exterior wythe. The panel cross-section and reinforcement details are illustrated in Figure 180 and Figure 181. The midspan connection detail is illustrated in Figure 182.

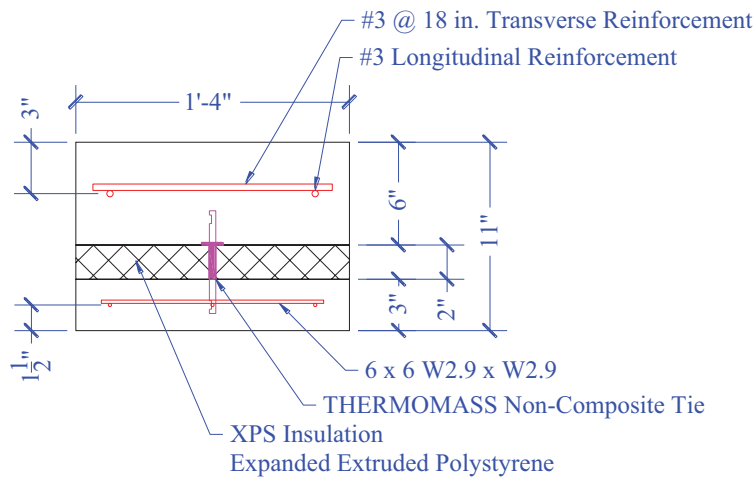

Figure 180. TS3-A, B Cross-Section Detail

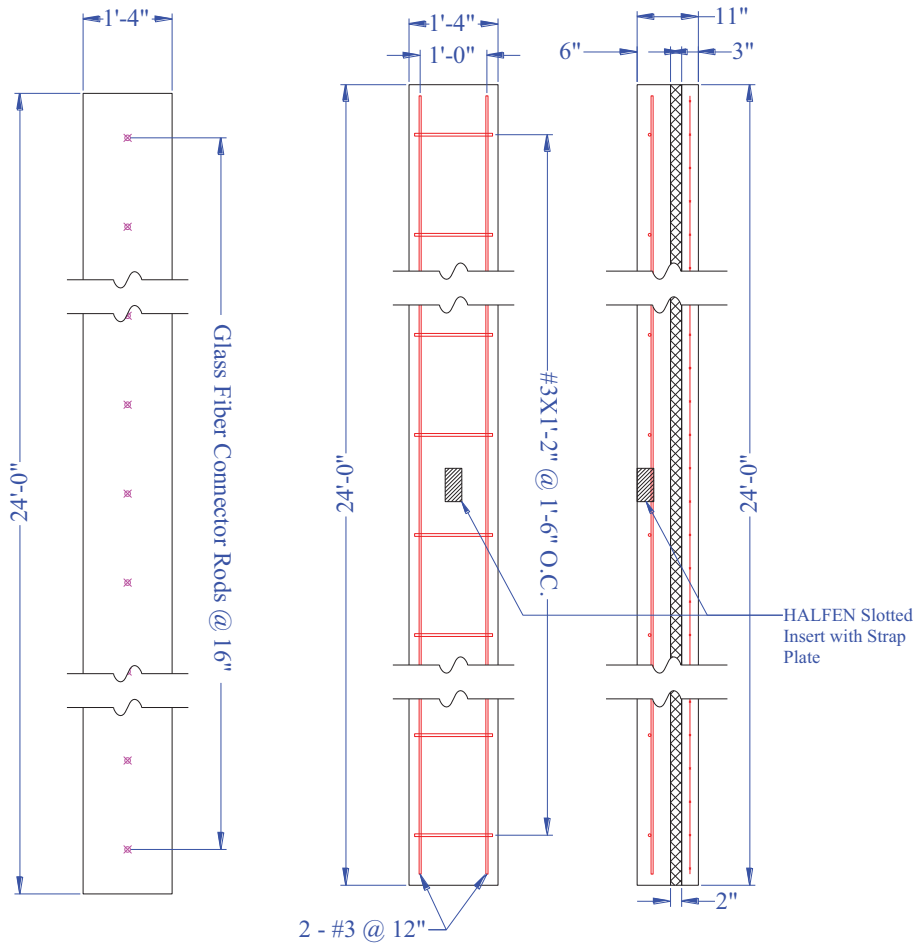

Figure 181. TS3-A, B Panel Detail

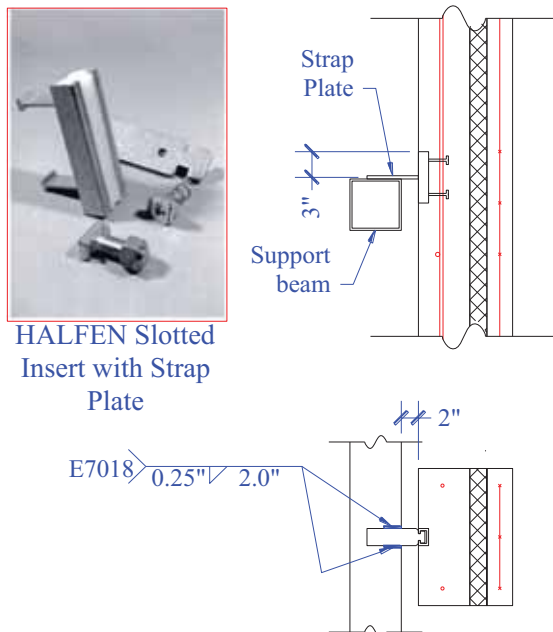

Figure 182. TS3-A, B Connection Detail

The measured response is summarized in Table 36. The midspan pressure displacement for the two specimen follows in Figure 183. The individual response of each panel, the end slips, and quarter point displacements are included in Figure 184-Figure 186.

Table 36. TS3-A and B Measured Response

Specimen	Age at Test [days]	Max Load [lbs]	Max Pressure [psi]	East Corresponding Displacement [in]	West Corresponding Displacement [in]	East Slip [in]	West Slip [in]	Measured (+) Moment Capacity (9/64wL ²)	Measured (-) Moment Capacity (1/4*wL ²)
TS3-A	128	14512.3	3.335	2.573	3.403	0.243	0.119	138.8	247
TS3-B	132	14210.9	3.265	1.914	2.654	0.193	0.016	135.9	242
Average		14361.6	3.300	2.243	3.028	0.218	0.067	137	244

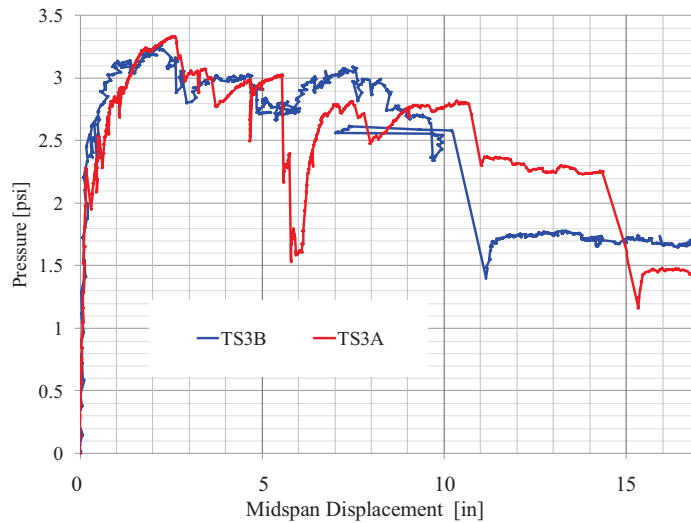

Figure 183. TS3-A, B Pressure-Displacement Response

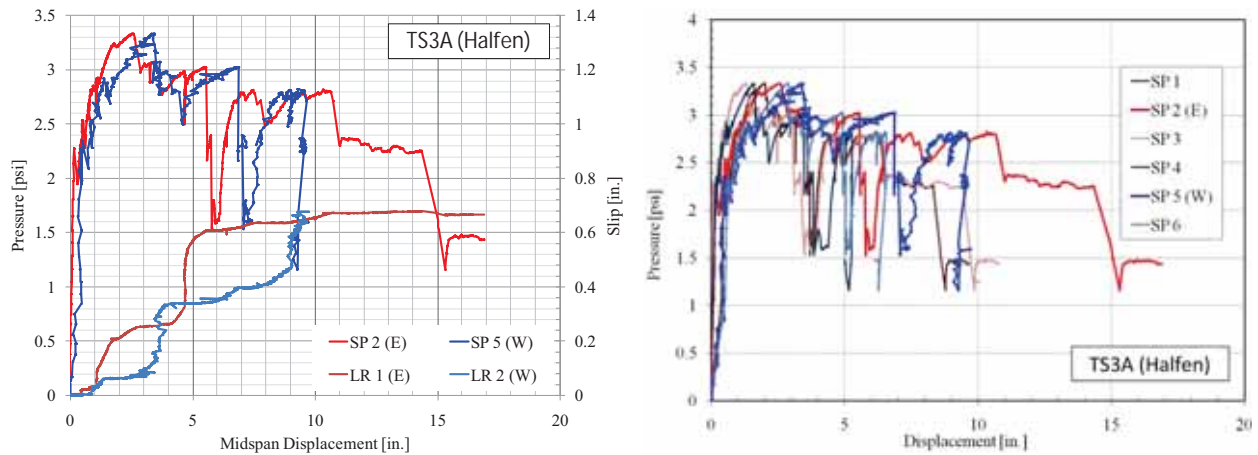

Figure 184. TS3-A Response

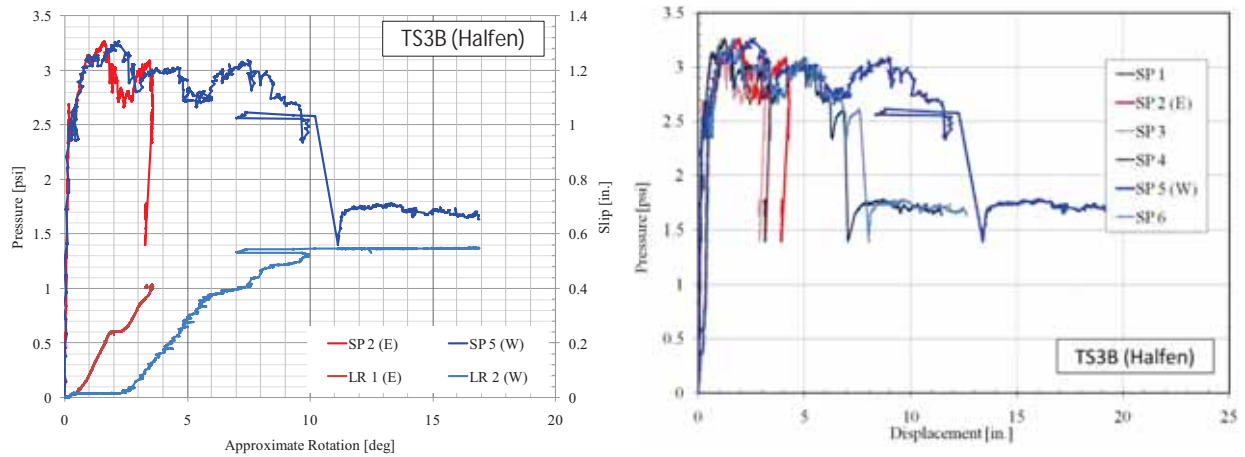

Figure 185. TS3-B Response



Figure 186. TS3 Panel Response (A, B)

8.4. TS3-C and D 6-2-3 Specimen Performance

TS3-C and D consist of a two-span non-composite 6-2-3 PC CSW panel fabricated with XPS insulation and glass fiber THERMOMASS® non-composite shear pins. The panel is non-

prestressed with rebar transverse reinforcement in the interior wythe and WWR in the exterior wythe. The panel cross-section and reinforcement details are illustrated in Figure 187 and Figure 188. The midspan connection consists of a bearing detail as illustrated in Figure 189.

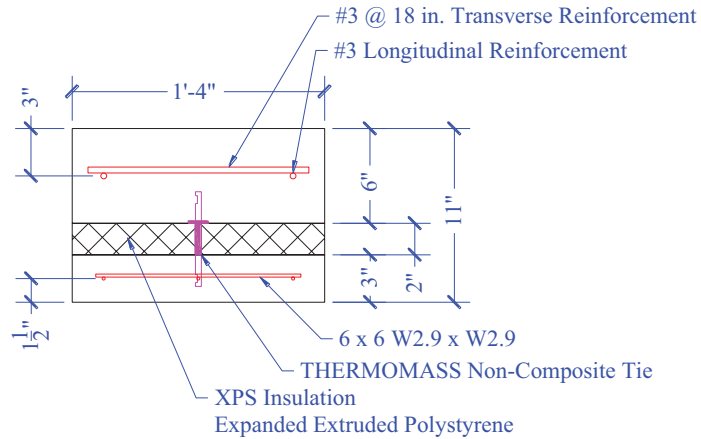

Figure 187. TS3-C, D Cross-Section Detail

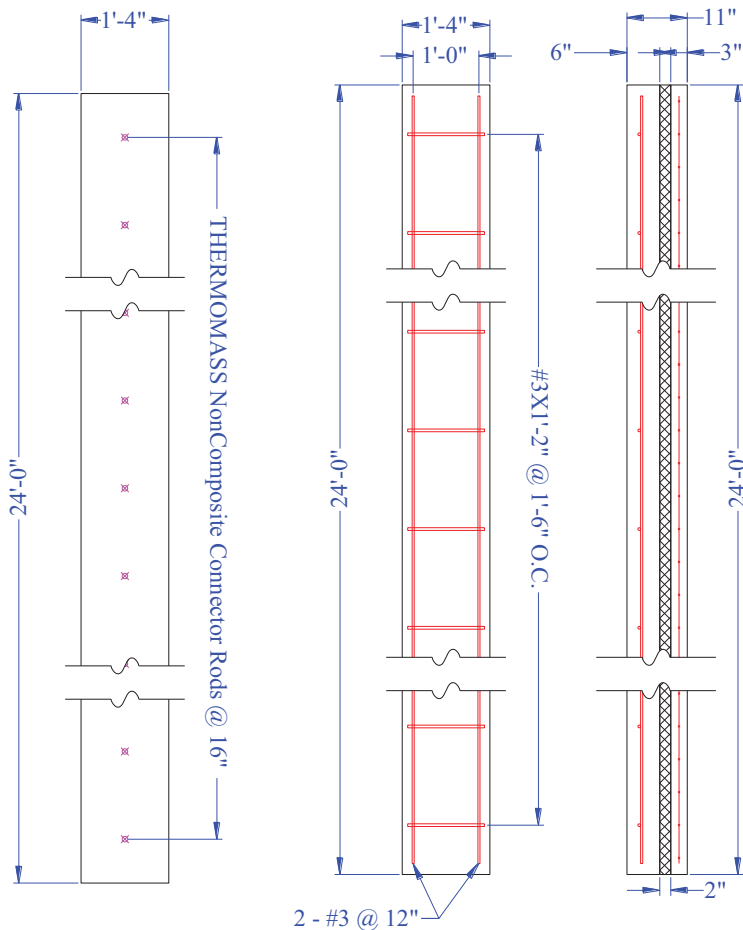

Figure 188. TS3-C, D Panel Detail

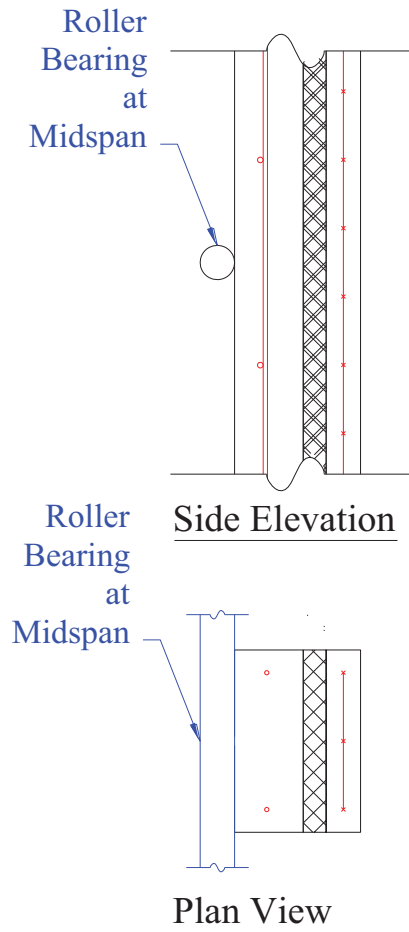

Figure 189. TS3-C, D Connection Detail

The measured response is summarized in Table 37. The midspan pressure displacement for the two specimen follows in Figure 190. The individual response of each panel, the end slips, and quarter point displacements are included in Figure 191-Figure 193.

Table 37. TS3-C and D Measured Response

Specimen	Age at Test [days]	Max Load [lbs]	Max Pressure [psi]	East Corresponding Displacement [in]	West Corresponding Displacement [in]	East Slip [in]	West Slip [in]	Measured (+) Moment Capacity (9/64wL ²)	Measured (-) Moment Capacity (1/4*wL ²)
TS3-C	126	12817.2	2.945	3.591	3.984	0.273	0.663	122.6	218
TS3-D	127	17073.1	3.923	2.206	2.420	0.003	0.001	163.3	290
Average		14945.1	3.434	2.899	3.202	0.138	0.332	143	254

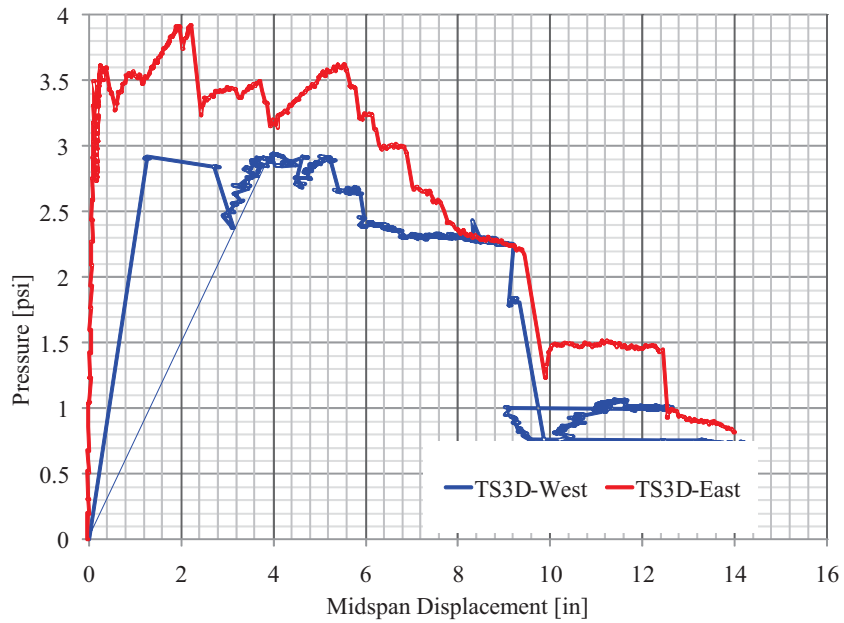

Figure 190. TS3-C, D Pressure-Displacement Response

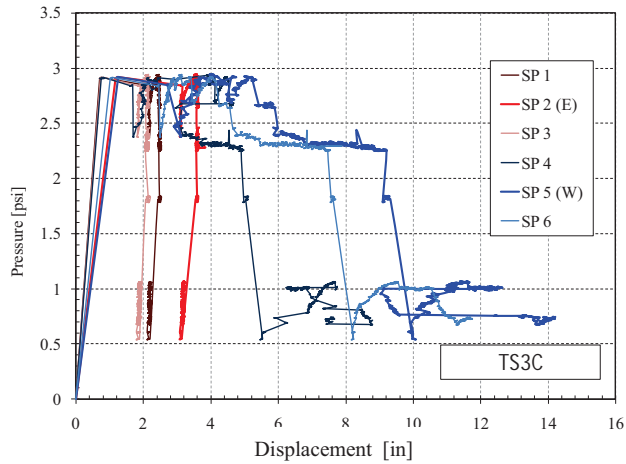
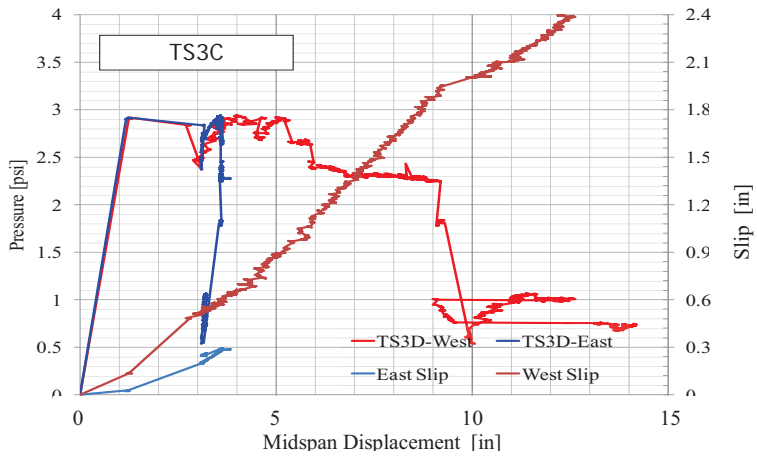

Figure 191. TS3-C Response

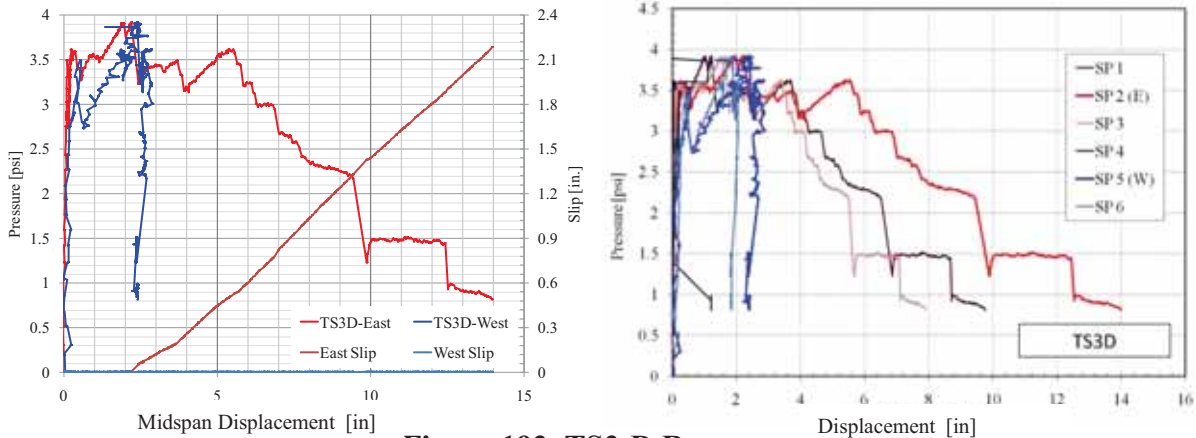

Figure 192. TS3-D Response



Figure 193. TS3 Panel Response (C, D)

8.5. TS3-E and F 6-2-3 Specimen Performance

TS3-E and F consist of a two-span non-composite 6-2-3 tilt-up CSW panel fabricated with XPS insulation and glass fiber THERMOMASS® non-composite shear pins. The panel is non-prestressed with rebar transverse reinforcement in the interior wythe and WWR in the exterior wythe. The panel cross-section and reinforcement details are illustrated in Figure 194 and Figure 195. The midspan stud group connection is illustrated in Figure 196.

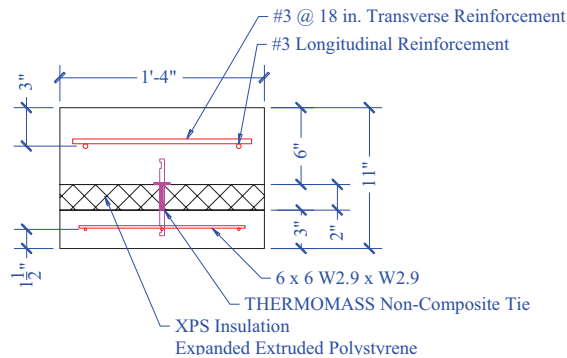

Figure 194. TS3-E, F Cross-Section Detail

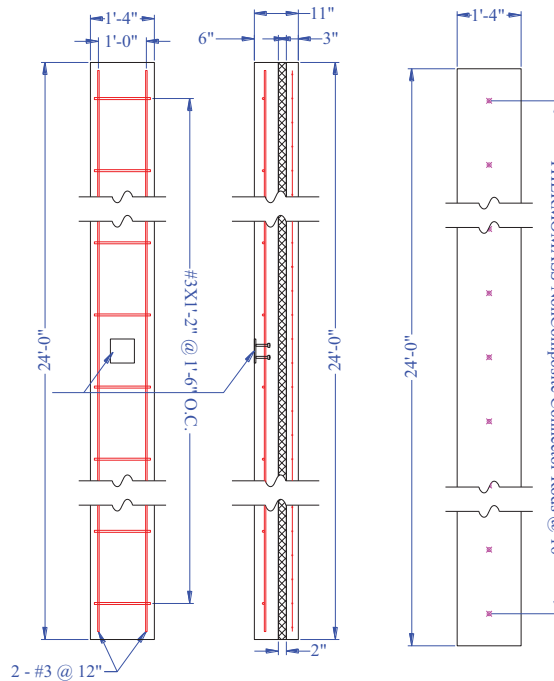

Figure 195. TS3-E, F Panel Detail

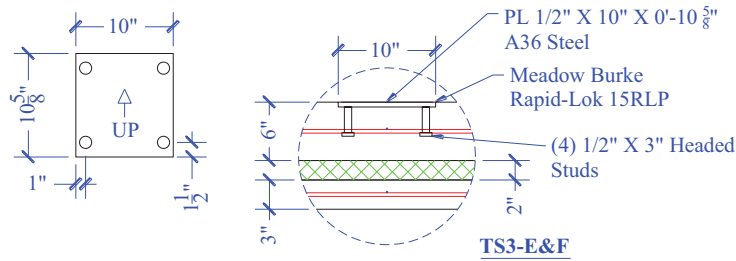

Figure 196. TS3-E, F Connection Detail

The measured response is summarized in Table 38. The midspan pressure displacement for the two specimen follows in Figure 197. The individual response of each panel, the end slips, and quarter point displacements are included in Figure 198-Figure 200.

Table 38. TS3-E and F Measured Response

Specimen	Age at Test [days]	Max Load [lbs]	Max Pressure [psi]	East Corresponding Displacement [in]	West Corresponding Displacement [in]	East Slip [in]	West Slip [in]	Measured (+) Moment Capacity (9/64wL ²)	Measured (-) Moment Capacity (1/4*wL ²)
TS3-E	136	13766.5	3.163	1.669	6.572	0.191	0.738	131.6	234
TS3-F	140	14363.8	3.301	1.282	2.791	0.150	0.213	137.4	244
Average		14065.1	3.232	1.476	4.681	0.171	0.475	134	239

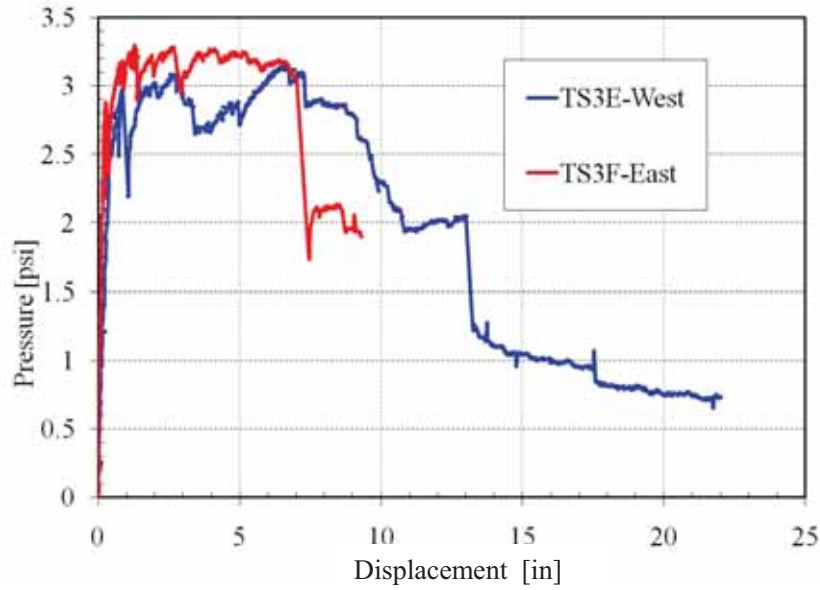

Figure 197. TS3-E, F Pressure-Displacement Response

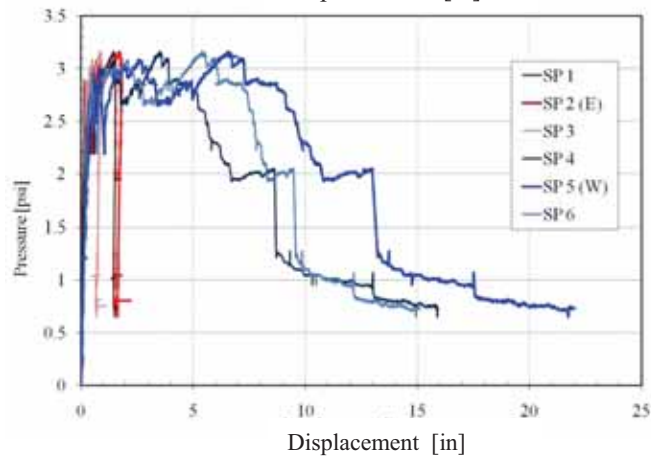
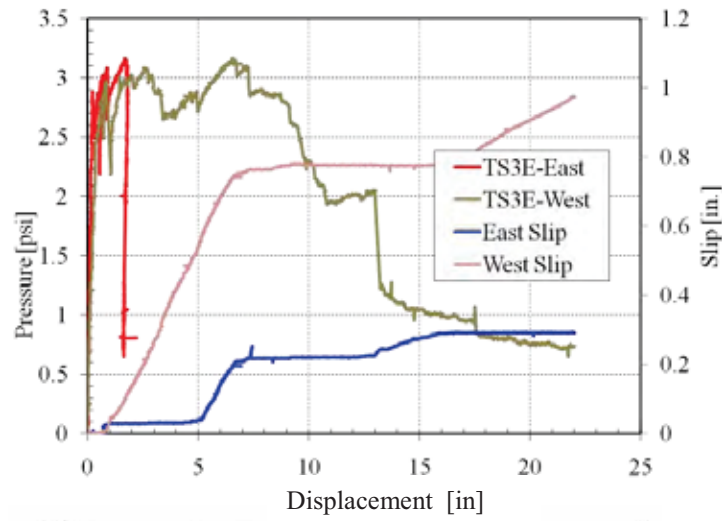

Figure 198. TS3-E Inbound Response

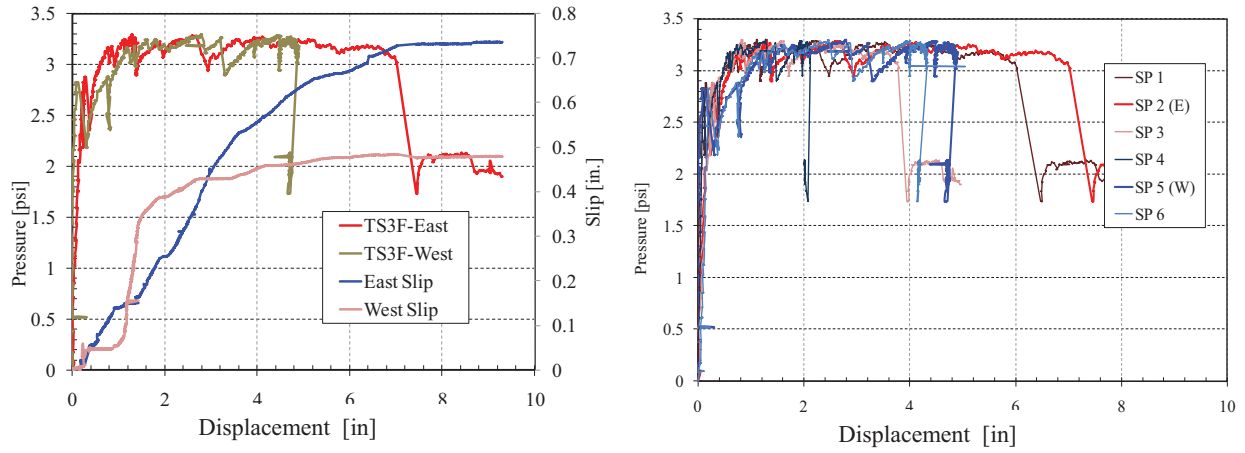

Figure 199. TS3-F Rebound Response



Figure 200. TS3 Panel Response (E, F)

9. DISCUSSION OF RESULTS

The results of the static uniform load experiments are examined in this chapter. The results are discussed relative to the single-span, two-span, single-span with end connections, and single-span with unbonded reinforcement.

9.1. Single-span Panels

The average response of all the single-span panels without end connections is illustrated in Figure 201-204. The average response from each group of experiments was computed by averaging pressure for each displacement level as illustrated in Figure 205.

Two tilt-up concrete panels were fabricated. TS1, a 6-2-3 panel, was detailed with non-composite shear ties and was designed to have the interior 6-in wythe provide all the flexural strength. Panel TS2, a 3-2-3 panel, was designed with composite shear ties. The composite panel was able to provide greater strength with similar deformation capacity.

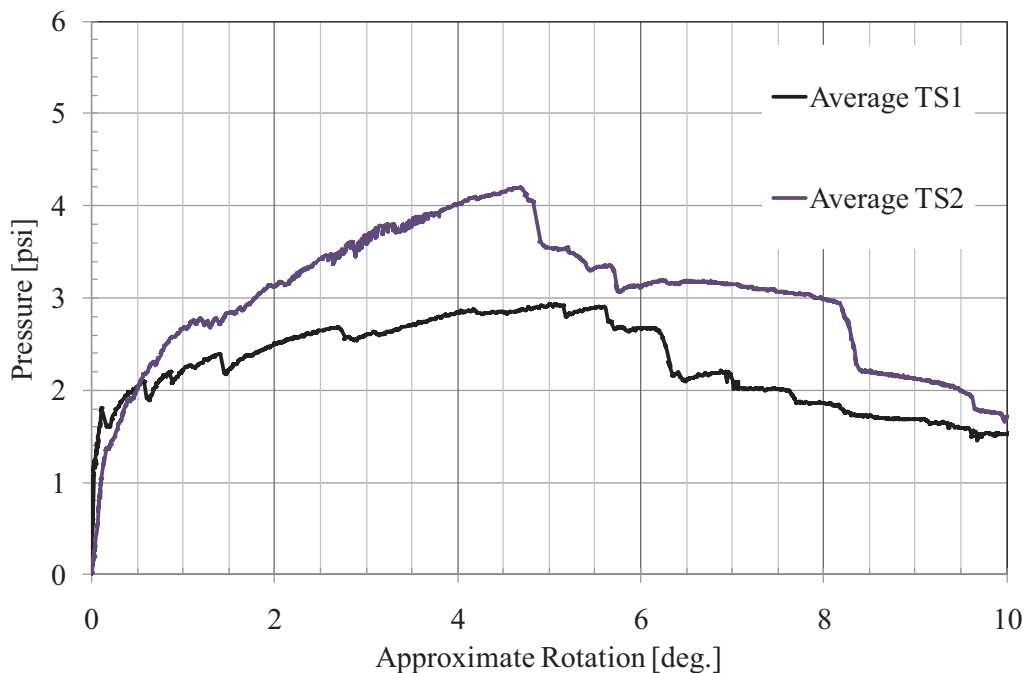

Figure 201. Average Single-span Tilt-Up Panels

The 3-2-3 panels are presented in Figure 202. The three panels containing conventional non-prestressed longitudinal reinforcement, TS2, PCS3, and PCS3 (Type2), were capable of achieving support rotations of greater than 4 degrees prior to strength degradation. The prestressed panels PCS1 and PCS2 achieved less ductility than the non-prestressed panels. A comparison of PCS1 and PCS2 shows that the response is sensitive to the tie type used. Both panels contain the same flexural reinforcement. PCS1 uses steel C-clips while PSC2 uses C-Grid®. The C-Grid® has a much greater stiffness than that of the C-clips and consequently softens at a higher pressure level.

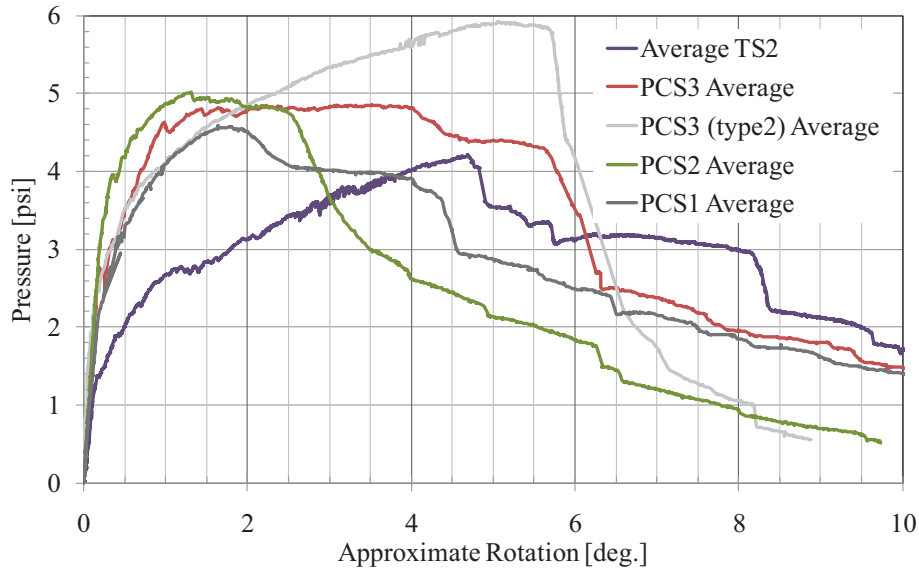

Figure 202. Average Single-span Response 3-2-3 Panels

The response of the 3-2-3 panels is sensitive to the shear tie connectors and foam type used, as illustrated in Figure 203. Aside from panel PCS7, all 3-2-3 panels began with the same elastic stiffness. PCS4, 5, and 6 all contain the same flexural reinforcement and XPS insulation. The ties vary and include C-Clips, glass pins, and C-Grid® for PCS4, 5, and 6, respectively. The post-cracking stiffness varies in accordance with the tie stiffness. The C-clip is the least stiff followed by the glass pins, and the C-Grid®. The use of unsealed PIMA insulation significantly increases the early stiffness of the panel over that of XPS insulation. This can be observed when comparing PCS6 to PCS9. The use of one insulating form layer is critical for composite action. PCS8 was fabricated using two layers of PIMA with sealed interface between layers. This break in the insulation resulted in a reduction in strength and stiffness over that of XPS. This can be observed when comparing PCS5 to PCS8.

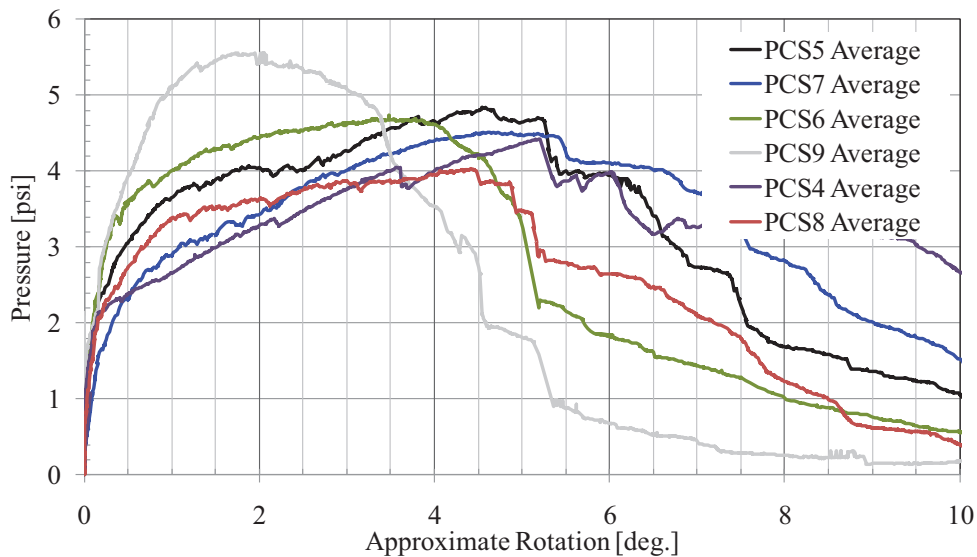

Figure 203. Average Single-span Response 3-2-3 Panels

The use of an unbonded region of prestressing reinforcement was intended to enhance the flexural ductility of the panel. As illustrated, the use of unbonding marginally reduced the flexural stiffness of the panel. The failure modes and strength were not affected. Forensic evaluation of the panels after testing revealed mortar on the unbonded strand. It is likely that the strand was not correctly unbonded in this test series.

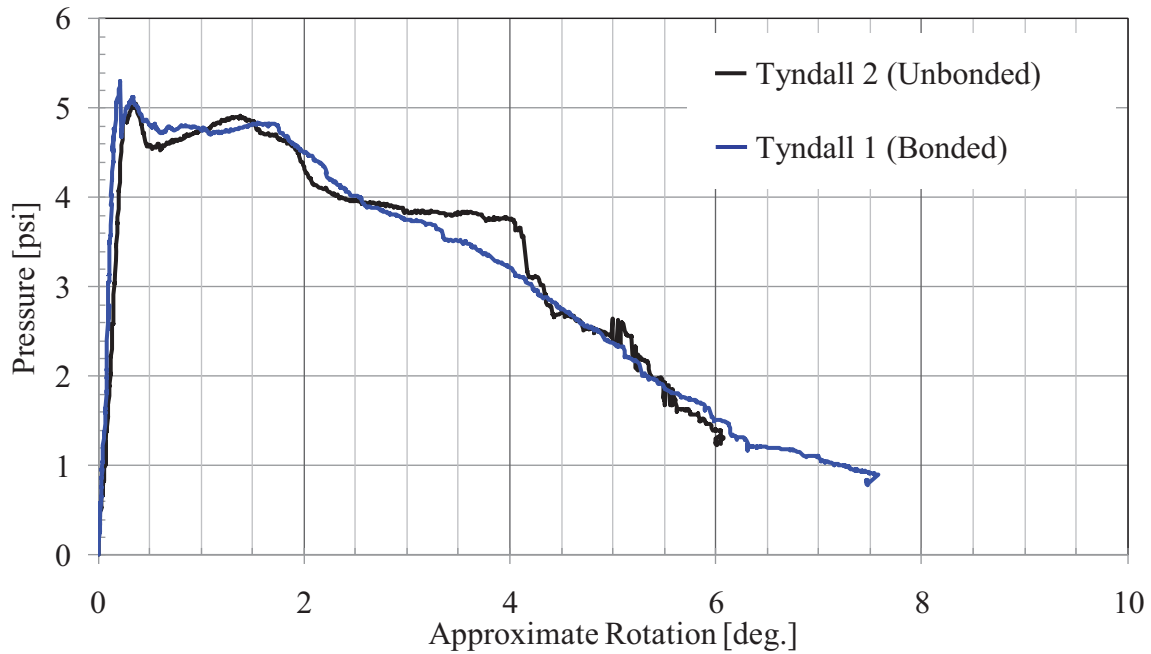

Figure 204. Average Single-span Response 3-4-3 Panels

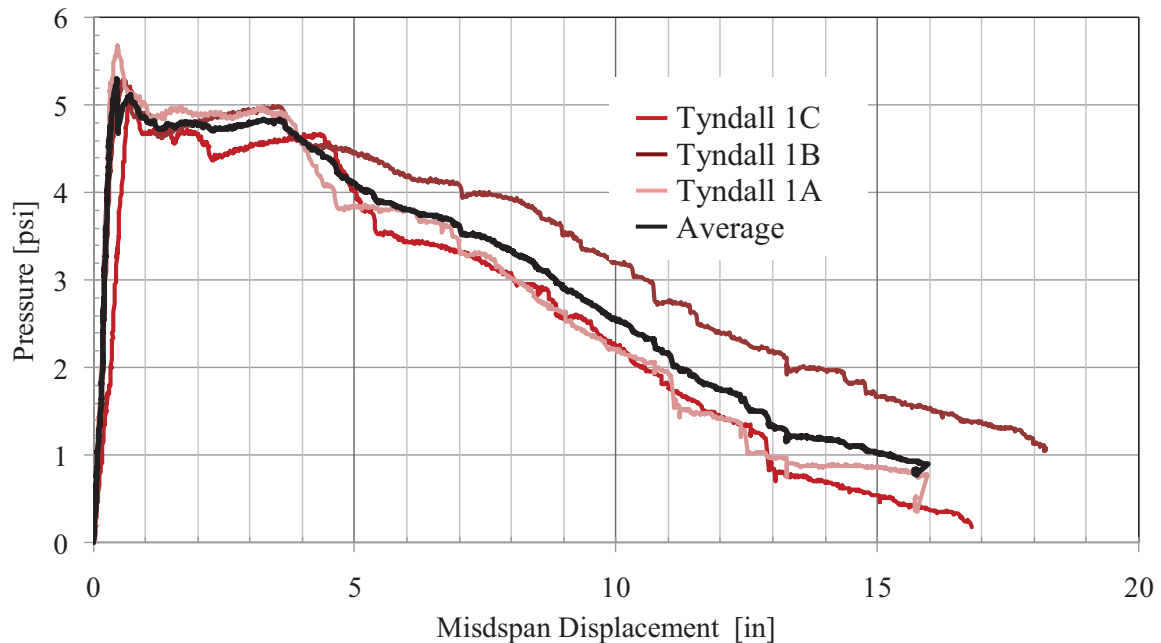

Figure 205. Average Computation

The use of prestressing strand versus conventional non-PS reinforcement is compared in specimens PCS2 and PCS3 (Figure 206). Both specimens achieved approximately the same flexural strength. The use of non-prestressed reinforcement results in a softening behavior due to cracking. This is not as evident in the PS section (PCS2). The use of PS reduces the deformation ductility by approximately 50%. This inability to support larger deformations supports the lower response limits used for PS elements. The addition of supplemental non-prestressed reinforcement, however, improves the ductility to that of the non-PS case. Therefore, for panels where large rotations are needed, addition of non-PS reinforcement should increase the ductility of the system.

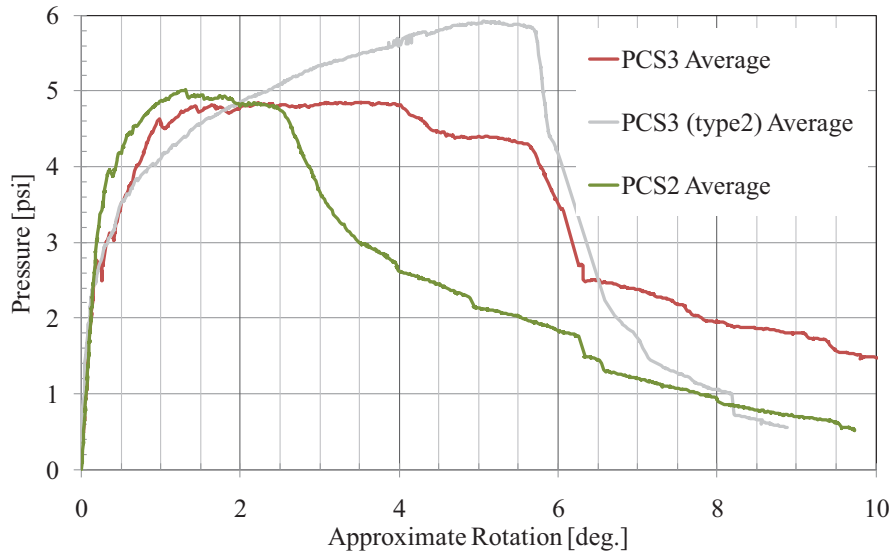

Figure 206. Prestressed versus Non-PS Reinforcement

The panel strength is directly related to the foam type used. Panels were fabricated with the same reinforcement but different thickness and type of foam. A 3-2-3 and a 3-3-3 panel were tested with the same reinforcement. Based on composite action, the 3-3-3 panel should provide a higher moment capacity than that of the 3-2-3 panel due to the larger moment arm. The two panels, however, achieved approximately the same strength. This can be observed when comparing PCS1 to PCS4 and PCS2 to PCS6 (Figure 207). In both cases the use of XPS (over EPS) insulation resulted in a softer post-cracking stiffness, larger ductility, and lower strength (even with the larger moment arm). The use of PIMA increased the strength of the panels further. This can be observed when comparing PCS6 to PCS9. It is noted that both the EPS and PIMA have a rough absorbent surface compared to the XPS insulation, which is smooth and sealed. The additional roughness provided additional horizontal shear strength against flexural demands. The THERMOMASS® panels exhibited the opposite behavior. The use of PIMA resulted in a decrease in strength over the XPS panel. The reason for this decrease is due to the fact that two 1.5-in thick PIMA sheets were used to make up the 3-in foam thickness needed in PCS8. This created a slip plane in the insulation thus reducing the shear strength.

Based on these results, the use of rough absorbent insulation foam can be used to increase the post-cracking stiffness and flexural strength of a panel. The use of multiple layers of foam or XPS foam will reduce these effects, but will typically allow more deformation prior to failure.

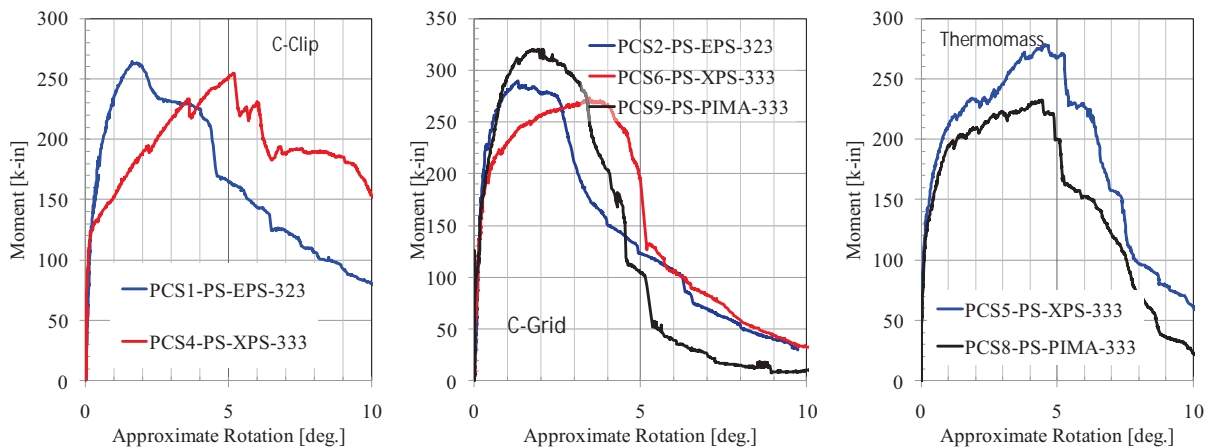

Figure 207. Influence of Foam

The panel capacity was estimated using two methods. The first method was performed in accordance with ACI 318 flexural strength formulations, and the second method used strain compatibility. All longitudinal reinforcement was accounted for in the strength estimates. The as-built dimensions of the reinforcement were used for the estimates. The ACI formulation followed a popular method of simplification. The reinforcement in both wythes was lumped at a centroid location. The total area of steel and the associated moment arm were used. The strain compatibility analysis method accounted for the doubly reinforced geometry of the section. The estimated capacities are compared to the measured capacities in Table 39.

The panels range from a low of 36% composite to 134% composite with an average of 71% composite. In general the panels were not able to reach their estimated composite flexural strength. Only the tilt-up 3-2-3 panel TS2 and reinforced concrete PCI type panel with non-PS reinforcement and C-Grid® PCS3 were able to exceed their estimated composite strength. The other panels behaved partially composite.

9.1.1. Backbone Estimation of Response

To compare the results of the static experiments to the current response limits, the results were simplified into a backbone or multi-linear resistance function. Backbones are an approximate representation of the relationship between two variables. Whereas some methods of empirical characterization tend to focus on one variable—e.g., yield point through offset yield method—backbones attempt to capture an entire response. Figure 208 shows the backbones developed from the measured responses for one set of single-span panels. Note that the variability between PCS3 specimens is large and is not typical of the other samples.

Table 39. Strength Estimates

Specimen	Wythe Configuration	Insulation	Panel Reinforcement	Composite Ties	Average Measured Moment Capacity	Estimated Composite Capacity		Estimated Non-Composite Capacity		% Composite	
						Strain Compat.	ACI 318	Strain Compat.	ACI 318	Strain Compat.	ACI 318
TS1	6-2-3	XPS	R.C.	THERMOMASS® - NC	89.4	110.7	110.7	42.4	41.8	69%	69%
TS2	3-2-3	XPS	R. C.	THERMOMASS® - Comp	121.3	99.8	99.8	36.1	33.5	134%	132%
PCS1	3-2-3	EPS	PS/WWR	Steel C-clips	259.1	342	335	122	103	62%	67%
PCS2	3-2-3	EPS	PS/WWR	C-Grid®	294.8	337.6	326.5	113.4	94.8	81%	86%
PCS3	3-2-3	EPS	Rebar/WWR	C-Grid®	306.1	275.5	275.5	89.7	83.2	116%	116%
PCS4	3-3-3	XPS	PS/Rebar	Galvanized Steel C-clips	268.3	379.3	368.7	114.5	97	58%	63%
PCS5	3-3-3	XPS	PS/Rebar	THERMOMASS® - Comp	279.7	369	358.8	104.3	87	66%	71%
PCS6	3-3-3	XPS	PS/WWR	C-Grid®	249.8	393.6	382.8	121.9	103.5	47%	52%
PCS7	3-3-3	XPS	Rebar	THERMOMASS® - Comp	268.5	310.3	310.3	92.8	87.1	81%	81%
PCS8	3-3-3	PIMA	PS/Rebar	THERMOMASS® - Comp	231.6	365.3	355.4	100.7	83.5	49%	54%
PCS9	3-3-3	PIMA	PS/WWR	C-Grid®	322.9	398.2	387.4	126.5	107.9	72%	77%
PCS10	3-3-3	XEPS 1#	PS/WWR	C-Grid®	275.9	388.1	377.2	115.7	97.4	59%	64%
PCS11	3-3-3	XEPS 1#	PS/WWR	C-Grid®	307.5	407.2	397.7	134.6	117.9	63%	68%
PCS3 (T2)	3-2-3	EPS	PS&Rebar/WWR	C-Grid®	332.4	573.9	578.1	196.6	153.4	36%	42%

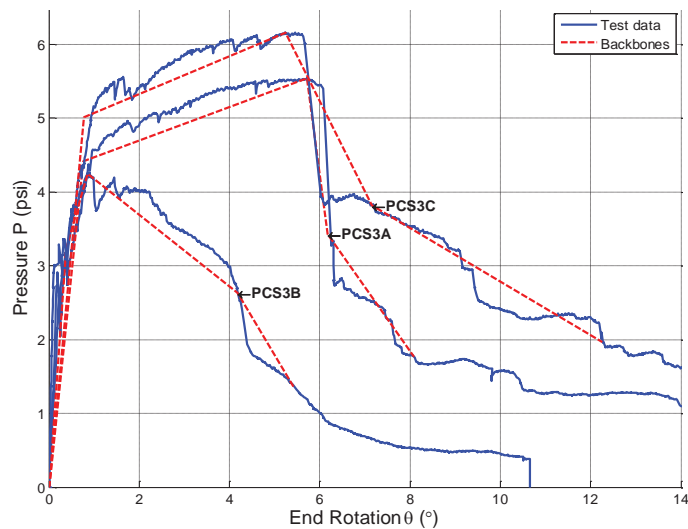

Figure 208. Pressure–Rotation Characterization (1 psi = 6.9kPa)

A four-point backbone of each experiment was developed (Fig. 209) and used to quantify the average response of the PS and reinforced concrete specimens. A procedure was developed to minimize the error between the energy of the measured performance and that of the backbone. Seven points are used to characterize the response: K, L, L0, L1, M, S, and T. Point M corresponds to the maximum pressure and corresponding rotation response, θ . K represents a point on the response in the elastic range. L0 represents the point where a secant through point K intersects the maximum pressure. Point L1 represents the point on the response at the same rotation level as point L0. Point L represents the intersection of the lines formed from the secant through point K and the line formed between point M and L1. Points S and T represent the descending branch of the response. The points K, S, and T were chosen as a percentage of P_{max} that would minimize the error between the measured pressure-rotation response and the final backbone. The error was computed as shown in Equation 3.

$$\text{error} = \frac{\int P\Delta d\Delta(\text{actual}) - \int P\Delta d\Delta(\text{backbone})}{\int P\Delta d\Delta(\text{actual})} \quad (3)$$

Values for K, S, and T were determined as 64% P_{max} , 62% P_{max} , and 32% P_{max} , respectively. These values provide the lowest average error on the entire dataset of one-span panel tests. A sample backbone for specimen PCS5-C using these limits is illustrated in Figure 210.

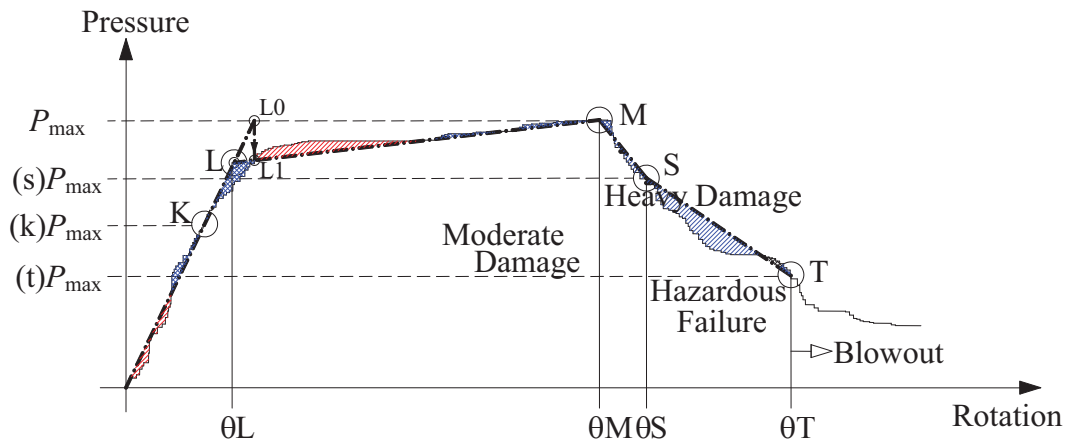

Figure 209. Backbone Development

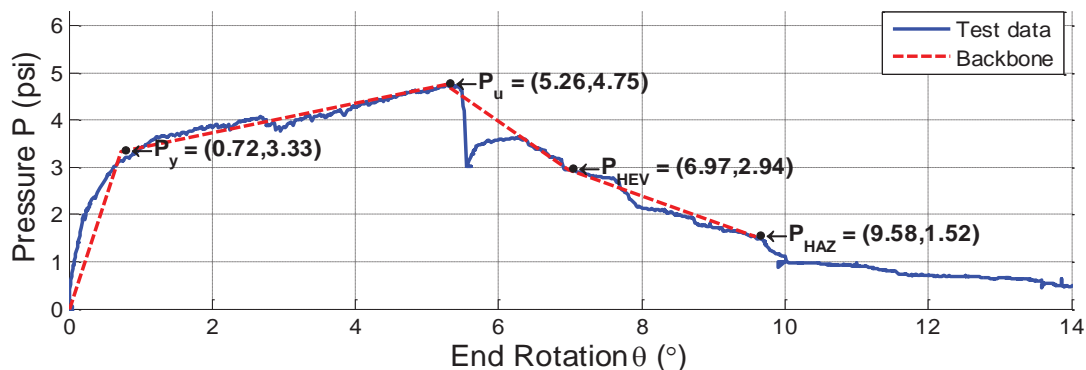

Figure 210. Backbone with Optimum Constants (1 psi = 6.9 kPa)

The backbone response was used to divide the panel response into different component damage levels. The division between superficial and moderate damage was not changed from the current recommendation of a ductility of 1.0. At the end of the superficial damage range, yielding initiates. Any damage prior to reinforcement yielding will be cosmetic in nature. The panels form a stable flexural response up to their ultimate capacity. Just past the ultimate strength, a flexural hinge occurs near midspan. The maximum load is used as the division between moderate and heavy damage. Heavy damage corresponds to the range from P_{max} to a decrease in the strength of 62% of P_{max} . Hazardous damage ranges from 62% P_{max} to 32% P_{max} . Blowout was assumed to occur at a strength of less than 32% of P_{max} .

The backbone response of each panel was averaged by type and is presented in Table 40. The end rotation for each backbone level (L, M, S, and T) for both the RC and PS concrete samples are summarized along with the average maximum pressure for each configuration. The results are sorted with respect to the construction type (RC or PS) and the end rotation at maximum pressure. The backbones for the reinforced and PS sandwich panels are shown graphically in Figure 211 and Figure 212, respectively.

Table 40. Average Backbone Response of Single-span Panels

Panel ID	P_{max} [psi]	Backbone rotation limits for damage levels [degrees]			
		θ_L	θ_M	θ_S	θ_T
PCS7 (RC)	4.64	1.1	5.8	7.6	9.8
TS1 (RC)	2.79	0.4	5.5	7.8	12.0
TS2 (RC)	4.21	1.0	5.0	8.7	10.7
PCS3 (RC)	5.31	0.6	3.9	5.8	8.6
PCS4 (PS)	4.66	1.7	5.9	9.0	15.9
PCS5 (PS)	4.85	0.7	4.9	7.0	8.5
PCS3 (Type 2) (PS)	5.77	0.9	4.6	5.6	6.3
PCS8 (PS)	4.16	0.5	4.6	6.4	7.6
PCS6 (PS)	4.30	0.3	2.7	4.6	6.7
PCS9 (PS)	5.60	0.5	2.0	4.0	4.7
PCS2 (PS)	5.11	0.2	1.8	3.3	6.2
PCS1 (PS)	4.47	0.4	1.7	5.2	11.9

Note: 1 psi = 6.9 kPa

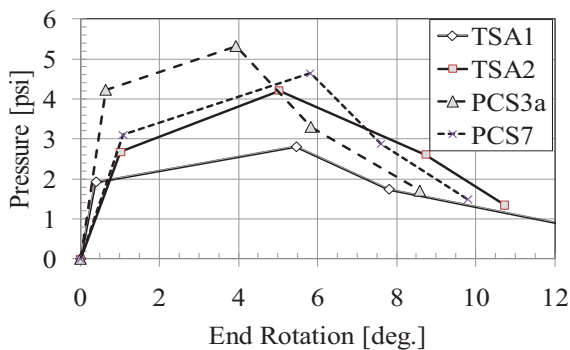

Figure 211. Reinforced Backbones

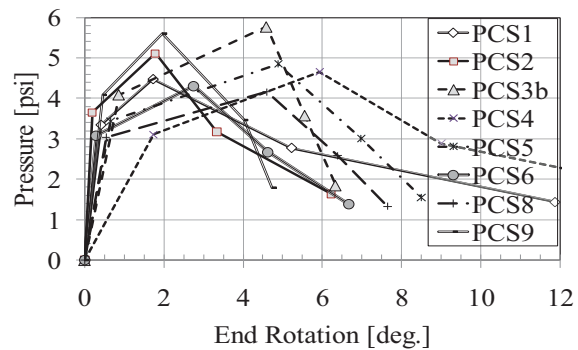

Figure 212. Prestressed Backbones

The 12 individual RC and 24 individual PS panel rotations were averaged to determine the general response limits of the insulated panels. The averages and standard deviations are summarized in Table 41 along with the current US Army response limitations [US Army 2008]. Recommended limits are developed for the RC and PS insulated sandwich panels based on Equation 4. Due to the small sample size the proposed response limits are reduced from the average rotation levels. The proposed limits are based on a Z-distribution with a 90% confidence level. (*AVE* is the average and *SD* is the standard deviation.)

$$\theta \leq AVE - 1.28 \times SD \quad (4)$$

Table 41. Average Rotation Capacity and Proposed Limits

	Superficial	Moderate	Heavy	Hazardous	Blowout
RC Flexural Limit	$\mu \leq 1.0$	$\theta \leq 2.0^\circ$	$2.0^\circ < \theta \leq 5.0^\circ$	$5.0^\circ < \theta \leq 10.0^\circ$	$\theta > 10.0^\circ$
RC Panel Response (<i>AVE</i> \pm <i>SD</i>)	$0.78^\circ \pm 0.34$	$5.06^\circ \pm 1.51$	$7.50^\circ \pm 1.44$	$10.29^\circ \pm 2.12$	-
Recommended RC Panel Limit	$\mu \leq 1.0$	$\theta \leq 3.1^\circ$	$3.1^\circ < \theta \leq 5.7^\circ$	$5.7^\circ < \theta \leq 7.6$	$\theta > 7.6$
PS Flexural Limit	$\mu \leq 1.0$	$\theta \leq 1.0^\circ$	$1.0^\circ < \theta \leq 2.0^\circ$	$2.0^\circ < \theta \leq 3.0^\circ$	$\theta > 3.0^\circ$
PS Panel Response (<i>AVE</i> \pm <i>SD</i>)	$0.65^\circ \pm 0.55$	$3.48^\circ \pm 1.67$	$5.61^\circ \pm 1.96$	$8.53^\circ \pm 3.84$	-
Recommended PS Panel Limit	$\mu \leq 1.0$	$\theta \leq 1.3^\circ$	$1.3^\circ < \theta \leq 3.1^\circ$	$3.1^\circ < \theta \leq 3.6^\circ$	$\theta > 3.6^\circ$

9.1.2. Estimation of Yield in Sandwich Wall Panels

Building structures with a High Level of Protection criterion are required to limit any damage of the exterior wall panels to superficial. This level of damage is defined as a ductility level of 1.0. Proper determination of this ductility level is critical for effective design of the wall element. The decision to use a lower bound or upper bound estimate of the wall will result in a high or moderate level of reinforcement, respectively.

Current U.S. Army approaches for determining yield deformations of flexural members are based on computation of an effective moment of inertia. The effective moment of inertia is based on an average of the cracked and gross moment of inertia of the panel. The yield deformation, Δ_y , is based on the intersection of the elastic stiffness, E_c , using the effective inertia, I_e , the flexural strength of the panel, w_y and the span length of the panel, L . The formulation follows in Equation 5.

$$\Delta_y = \frac{5w_y L^4}{384E_c I_e} \quad (5)$$

$$I_e = \frac{I_{\text{gross}} + I_{\text{cracked}}}{2} \quad (6)$$

Using this methodology, the yield displacement was computed for the as-built section using the average reinforcement measured from each specimen. The displacements were computed for the

assumption of full composite action and for the case of non-composite action. The predicted yield displacements are compared to the measured yield displacements in Table 42. The measured yield displacement correspond to the rotation point θ_L previously defined in Table 40.

The measured yield displacements are bounded by the composite and non-composite deflection predictions. In all cases, using the composite displacement predictions results in an underprediction of the actual displacement. Using the composite deformation prediction for the panels examined resulted in lower-bound estimate of deformation.

Table 42. Estimated and Actual Deformations

Specimen	Measured Yield Displacement [in]	Estimated Displacement [in]		Percent of Measured	
		Composite	Non-Composite	Composite	Non-Composite
TS1 (RC)	0.409	0.047	0.247	12%	60%
TS2 (RC)	1.061	0.103	0.961	10%	91%
PCS3 (RC)	0.669	0.111	1.447	17%	216%
PCS7 (RC)	1.134	0.086	1.129	8%	100%
PCS1	0.432	0.144	1.345	33%	311%
PCS2	0.201	0.141	1.318	70%	655%
PCS3 (Type 2)	0.903	0.220	2.092	24%	232%
PCS4	1.821	0.111	1.447	6%	80%
PCS5	0.687	0.108	1.414	16%	206%
PCS6	0.305	0.116	1.508	38%	495%
PCS8	0.561	0.107	1.400	19%	250%
PCS9	0.475	0.117	1.528	25%	322%

9.2. Multi-span Panels

The multi-span panels are compared in this section. The responses from the tests are averaged and backbones are created in a similar manner to that of the single-span panels. Sections of the panels are presented again in Figure 213. The pressure versus deformation of the panels are presented in Figure 214 and the simplified backbones are illustrated in Figure 215.

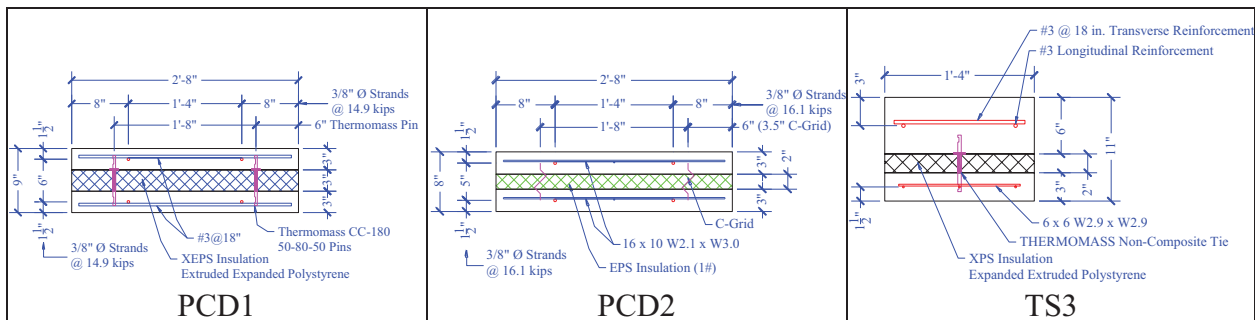

Figure 213. Two-span Sections

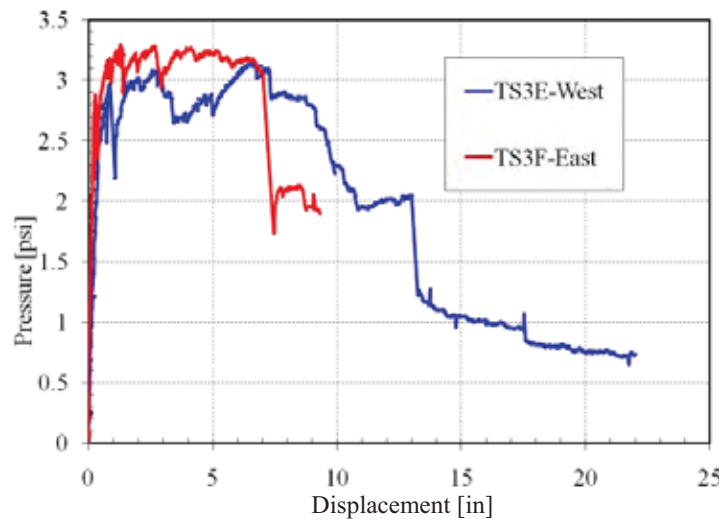
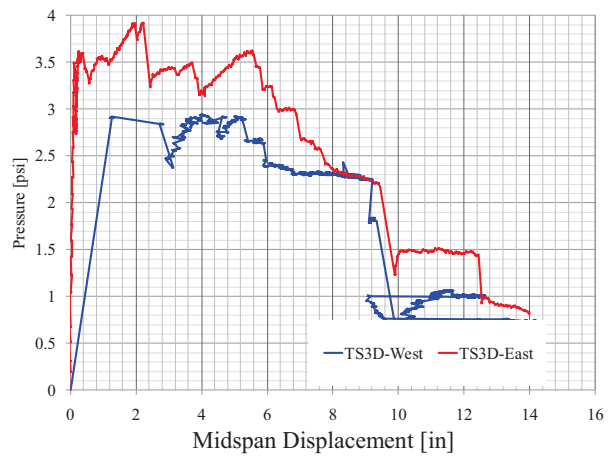
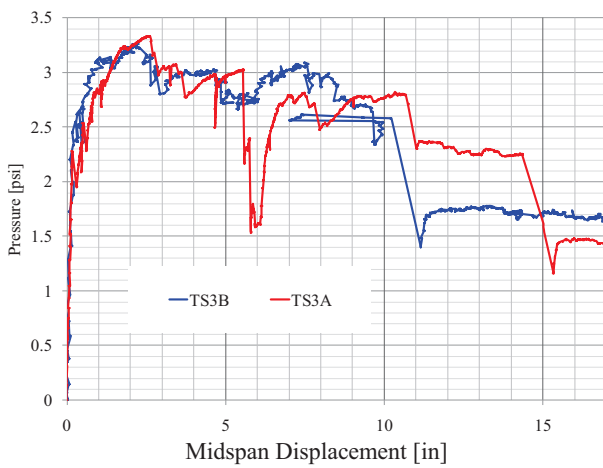
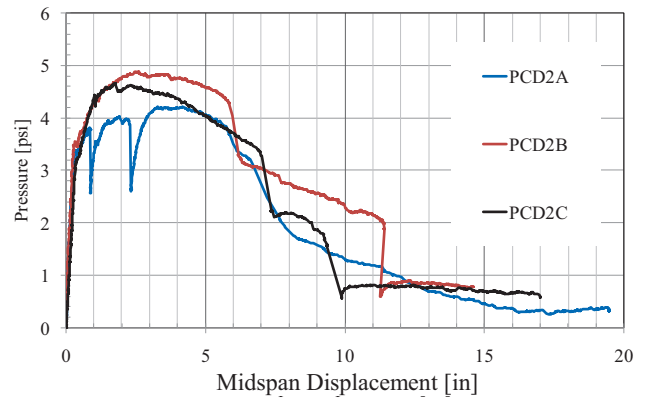
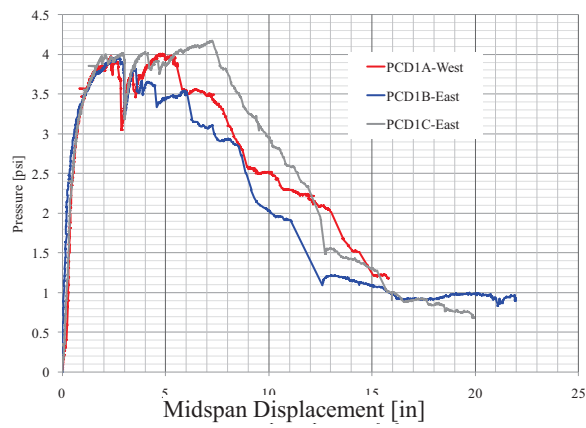

Figure 214. Measured Responses

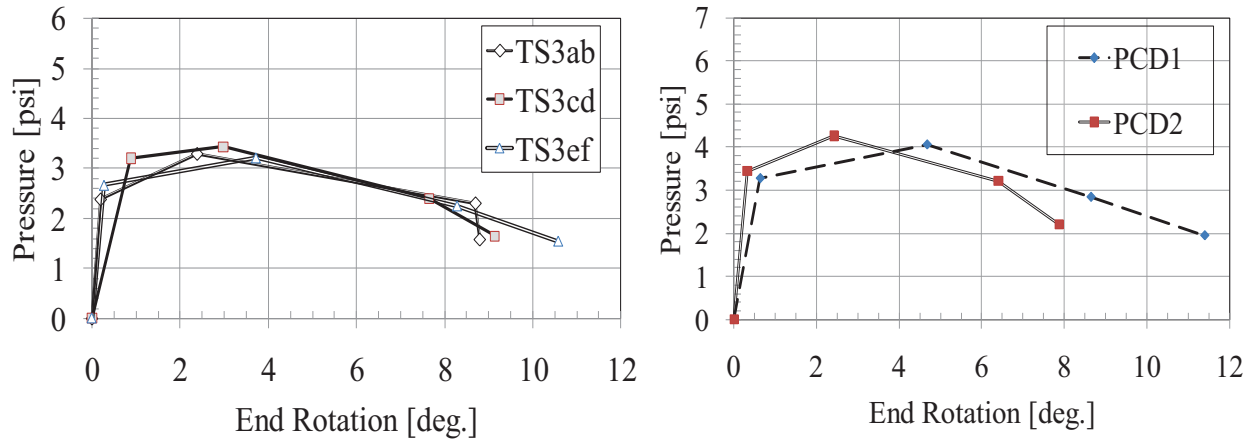

Figure 215. Backbone Curves

The average end rotations are presented for the two-span panels. The rotations are computed using the midspan deformations. As illustrated in Table 43, the multi-span panel rotations are on the same order as that of the single-span. The only exception is RC panel TS3, which has a lower rotational limit for the moderate damage level than the single-span, 2 degrees for TS3 versus 5 degrees for TS1. (The moderate damage is the rotation from θ_L to θ_M .) The sample size of experiments for the multi-span panels is too small to make generalized conclusions about the response of the system.

Observation of the damage to the multi-span systems revealed connection failures to the panels. For composite panels with 3-2-3 wythe arrangement, the mid-height connections punched through the interior concrete wythe. The connection regions were not reinforced with any special detailing. Due to the negative moment demands at the region, the connection zone was subjected to multi-directional compression. In addition, the flexure produced cracking. The combination of these demands and the lack of crossing reinforcement resulted in the punching failures observed. The 6-2-3 panels did not exhibit punching failures.

Table 43. Multi-span Panel Response

Panel ID	P_{max} [psi]	Backbone rotation limits for damage levels [degrees]			
		θ_L	θ_M	θ_S	θ_T
PCD1 (PS)	4.06	0.63	4.68	8.65	11.41
PCD2 (PS)	4.26	0.32	2.42	6.40	7.88
TS3-A, B (RC)	3.30	0.20	2.38	8.69	8.79
TS3-C, D (RC)	3.43	0.88	2.98	7.64	9.14
TS3-E, F (RC)	3.22	0.28	3.72	8.29	10.58

10. CONCLUSIONS AND FUTURE WORK

An experimental study of insulated CSW panels was conducted to assess performance under a pseudo-blast loading. Wall panels typical of current U.S. construction were fabricated and subjected to a monotonically increasing uniform load until failure. The resistance, deformation and failure characteristics were recorded and discussed in the preceding sections. Both single-span and multi-span panels with typical embedded connections were examined. Based on the results of the research program the following conclusions can be made:

- PS and non-PS concrete wall panels were shown to provide a ductile response when subjected to uniform loading.
- Non-PS panels provide greater ductility than PS panels.
- The addition of non-PS reinforcement to a PS panel allows the panel to achieve ductility levels of non-PS members.
- The shear ties used in the panel affect the flexural response of the system. Specifically, the use of stiff truss type ties results in a stiff flexural response, whereas the use of flexible C-clip ties results in more appreciable softening of the flexural response after cracking.
- Rough absorbent insulation foam can be used to increase the post-cracking stiffness and flexural strength of a panel. The use of multiple layers of foam or XPS foam will reduce these effects but will typically allow more deformation prior to failure.
- The panels range from a low of 36% composite to 134% composite with an average of 71% composite. In general, the panels were not able to reach their estimated composite flexural strength. Only the tilt-up 3-2-3 panel TS2 and reinforced concrete PCI type panel with non-PS reinforcement and C-Grid® PCS3 were able to exceed their estimated composite strength. The other panels behaved partially composite.
- The results indicate that insulated sandwich wall panels provide adequate deformation capability to meet current blast response criteria. At a minimum, insulated PC CSW panels can be used in accordance with the current blast design limitations.
- The current blast response limits may potentially be increased to the proposed limits. These new limits provide information useful for improving the efficiency and economy of an already efficient and economic blast-resistant construction system. This cost-saving potential may also lead to more consideration for blast resistance being given to sandwich panels rather than other alternatives.
- The measured yield displacements are bounded by the composite and non-composite deflection predictions. In all cases, using the composite displacement predictions results in an underprediction of the actual displacement.
- The data generated as part of the research study can be used to develop response models and estimation methods using finite element analysis and simplified methods. This work is ongoing.
- The addition of unbonded reinforcement in the center of the panel did not increase the flexural deformation capacity of the panels. It is possible that this observation was due to poorly constructed unbonded regions.
- Observation of the damage to the multi-span systems revealed connection failures to the 3-2-3 panels. For these panels, the mid-height connections punched through the interior concrete wythe. The connection regions were not reinforced with any special detailing. Due to the negative moment demands at the region, the connection zone was subjected to

multi-directional compression. In addition the flexure produced cracking. The combination of these demands and the lack of crossing reinforcement resulted in the punching failures observed. The 6-2-3 panels did not exhibit punching failures. The use of a solid zone at the connection region and the use of reinforcement crossing any potential punching zone would minimize this problem.

10.1. Further Research

This study examined the performance of conventional PC CSW construction. No special detailing was included to resist the effects of blast loading. Additional research is needed to examine the performance of these panels under axial demands. Furthermore, additional research should be conducted on the influence of enhanced blast specific design types.

Additional studies are being conducted using the results of this program to develop predictive models. The research is ongoing through a Cooperative Research and Development Agreement between the Portland Cement Association, the Precast/Prestressed Concrete Institute, the Tilt-up Concrete Association, the Air Force Research Laboratory, and faculty members from Auburn and Lehigh Universities.

11. REFERENCES

- American Concrete Institute (ACI) Committee 318, –Building Code Requirements for Structural Concrete and Commentary,” ACI 318-08, 2008.
- ASCE, –Minimum design loads for buildings and other structures.‘ ASCE/SEI 7-05, American Society of Civil Engineers, 2006.
- ASTM Standard C39, 2005, –Standard Test Method for Compressive Strength of Cylindrical Concrete Specimens,” ASTM International, West Conshohocken, PA, 2005, DOI: 10.1520/C0039_C0039M-05E01, www.astm.org.
- ASTM Standard C578, 2009a, –Standard Specification for Rigid, Cellular Polystyrene Thermal Insulation,” ASTM International, West Conshohocken, PA, 2009, DOI: 10.1520/C0578-09E01, www.astm.org.
- ASTM Standard A36, 2008, –Standard Specification for Carbon Structural Steel,” ASTM International, West Conshohocken, PA, 2007, DOI: 10.1520/A0036_A0036M-08, www.astm.org.
- ASTM Standard A82, 2007, –Standard Specification for Steel Wire, Plain, for Concrete Reinforcement,” ASTM International, West Conshohocken, PA, 2007, DOI: 10.1520/A0082_A0082M-07, www.astm.org.
- ASTM Standard A416, 2006, –Standard Specification for Steel Strand, Uncoated Seven-Wire for Prestressed Concrete,” ASTM International, West Conshohocken, PA, 2006, DOI: 10.1520/A0416_A0416M-06, www.astm.org.
- ASTM Standard A615, 2009b, –Standard Specification for Deformed and Plain Carbon-Steel Bars for Concrete Reinforcement,” ASTM International, West Conshohocken, PA, 2009, DOI: 10.1520/A0615_A0615M-09, www.astm.org.
- ASTM Standard A706, 2009c, –Standard Specification for Low-Alloy Steel Deformed and Plain Bars for Concrete Reinforcement,” ASTM International, West Conshohocken, PA, 2009, DOI: 10.1520/A0706_A0706M-09, www.astm.org.
- Meadowburke, –Precast Products Manual.” URL: <http://www.meadowburke.com/documents/precastercast/8%20PC%20Halfen.pdf>. Accessed April 5, 2011.
- Naito, C., Hoemann, J., Bewick, B., and Hammons, M., –Evaluation of Shear Tie Connectors For Use In Insulated Concrete Sandwich Panels,” Air Force Research Laboratory Report, AFRL-RX-TY-TR-2009-4600, December 2009, 31 pages.
- PCI Committee on Precast Sandwich Wall Panels, –State-of-the-Art of Precast/Prestressed Sandwich Wall Panels,” *Journal of the Precast/Prestressed Concrete Institute*, 42 (2), 1997.
- PCI Industry Handbook Committee, –PCI Design Handbook Precast and Prestressed Concrete,” 6th Edition, PCI MNL 120-04, Chicago, IL, USA, 2004.
- Tilt-up Concrete Association, –Tilt-Up Construction and Engineering Manual (6th ed.),” Mount Vernon, IA, USA: 2006.
- US Army Corps of Engineers, –Single Degree of Freedom Structural Response Limits for Antiterrorism Design,” Report PDC-TR 06-08, October, 2008.

LIST OF SYMBOLS, ABBREVIATIONS, AND ACRONYMS

ACI	American Concrete Institute
AFRL	Air Force Research Laboratory
A_{ps}	area of prestressing steel in flexural tension zone
ASTM	American Society for Testing and Materials
ATFP	Anti-Terrorism and Force Protection
b	width of compression face of member
COV	coefficient of variation (standard deviation divided by mean)
CRADA	Cooperative Research and Development Agreement
CSW	concrete sandwich wall
d_p	distance from extreme compression fiber to centroid of prestressing steel
E_c	elastic stiffness
EPS	expanded polystyrene
f_{ci}	design compression strength at release
f'_c	design compressive strength at 28 days
f_{ps}	stress in prestressing steel at nominal flexural strength
I_e	effective inertia
kip	thousand inch-pounds
L	span length
LOP	level of protection
PC	precast
PCA	Portland Cement Association
PCI	Precast/Prestressed Concrete Institute
PDC	Protective Design Center
PIMA	polyisocyanurate
P_{max}	maximum pressure
PS	prestressed
RC	reinforced concrete
TCA	Tilt-Up Concrete Association
WWR	welded wire reinforcement
w_y	flexural strength
XPS or XEPS	extruded expanded polystyrene
Δ_{mid}	midspan displacement
Δ_{y-mid}	midspan yield displacement
Δ_y	yield deformation
θ	support rotation
θ_L	rotation at the onset of moderate damage
θ_M	rotation at the onset of heavy damage
θ_S	rotation at the onset of hazardous failure
θ_T	rotation at blowout
μ	ductility
ω_p	prestressed reinforcement index